

# User Guide

---

Samsung Multifunction **ProXpress**

C306x series

## **BASIC**

This guide provides information concerning the installation, basic operation and troubleshooting on Windows.

## **ADVANCED**

This guide provides information about installation, advanced configuration, operation and troubleshooting on various OS environments.

Some features may not be available depending on models or countries.



## 1. Introduction

Key benefits	5
Features by model	7
Useful to know	9
About this user guide	10
Safety information	11
Machine overview	17
Control panel overview	21
Turning on the machine	23
Installing the driver locally	24
Reinstalling the driver	26



## 2. Menu Overview and Basic Setup

Menu overview	28
Machine's basic settings	41
Media and tray	42
Basic printing	57
Basic copying	64
Basic scanning	69
Basic faxing	70
Using USB memory device	74



## 3. Maintenance

Ordering supplies and accessories	81
Available supplies	82
Available accessories	83
Available maintenance parts	84
Storing the toner cartridge	85
Redistributing toner	87
Replacing the toner cartridge	89
Replacing the waste toner container	92
Installing accessories	94
Monitoring the supplies life	96
Setting the toner low alert	97
Cleaning the machine	98
Tips for moving & storing your machine	104



## 4. Troubleshooting

Tips for avoiding paper jams	106
Clearing paper jams	107
Understanding the status LED	120
Understanding display messages	122



## 5. Appendix

<b>Specifications</b>	<b>130</b>
<b>Regulatory information</b>	<b>140</b>
<b>Copyright</b>	<b>153</b>



# 1. Introduction

This chapter provides information you need to know before using the machine.

- **Key benefits** 5
- **Features by model** 7
- **Useful to know** 9
- **About this user guide** 10
- **Safety information** 11
- **Machine overview** 17
- **Control panel overview** 21
- **Turning on the machine** 23
- **Installing the driver locally** 24
- **Reinstalling the driver** 26

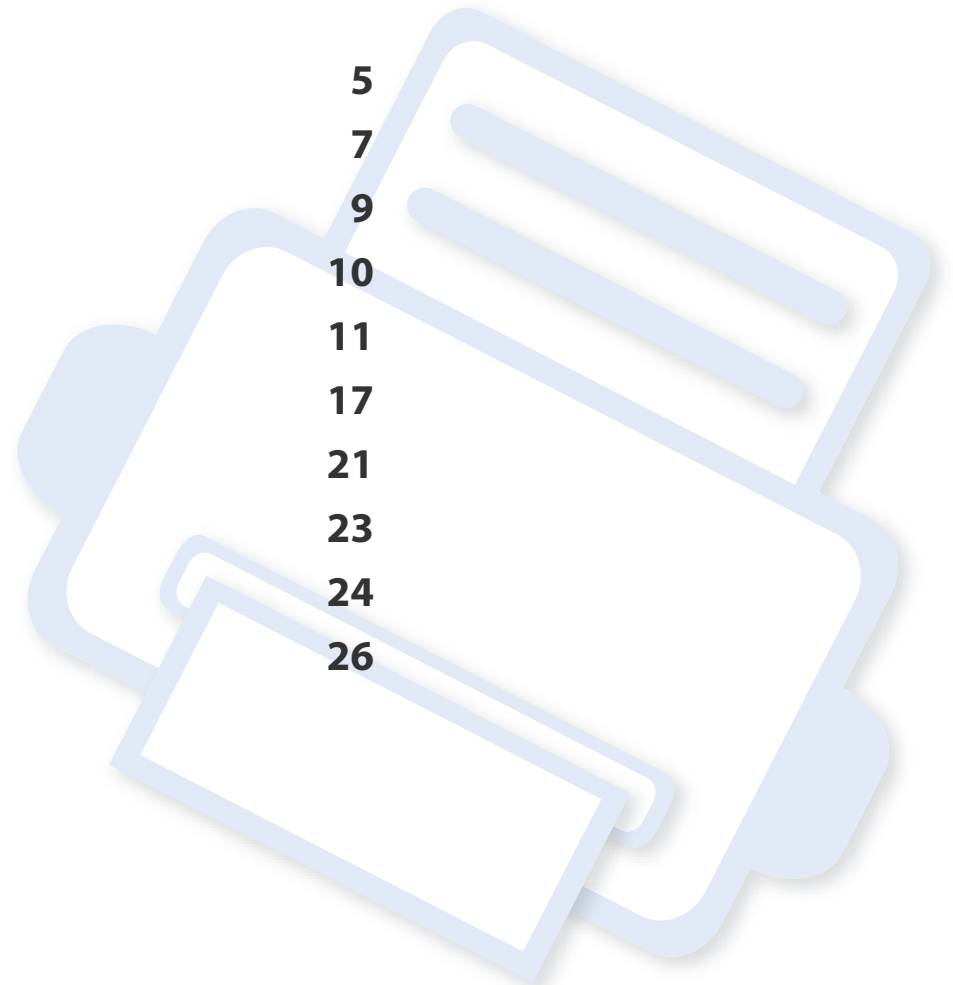



# Key benefits

## Environmentally friendly



- To save toner and paper, this machine supports Eco feature (see "Eco printing" on page 61).
- To save paper, you can print multiple pages on one single sheet of paper (see "Using advanced print features" on page 261).
- To save paper, you can print on both sides of the paper (double-sided printing) (see "Using advanced print features" on page 261).
- To save electricity, this machine automatically conserves electricity by substantially reducing power consumption when not in use.
- We recommend using recycled paper for saving energy.

## Fast high resolution printing



- You can print in a full range of colors using cyan, magenta, yellow, and black.
- You can print with a resolution of up to 9,600 x 600 dpi effective output (600 x 600 x 4 bit).

- Fast, on-demand printing.
  - For single-side printing, up to 30 ppm (A4) or up to 31 ppm (Letter).

## Convenience



- You can print on the go from your smartphone or computer using Samsung Cloud Print apps (see "Samsung Cloud Print" on page 204).
- Simply touch your mobile device on the NFC tag on your printer and get the print job done (see "Using the NFC feature" on page 191).
- You can print on the go from your smartphone or computer using Google Cloud Print™ enabled apps (see "Google Cloud Print™" on page 209).
- Easy Capture Manager allows you to easily edit and print whatever you captured using the Print Screen key on the keyboard (see "Easy Capture Manager" on page 302).
- Samsung Easy Printer Manager and Printing Status is a program that monitors and informs you of the machine's status and allows you to customize the machine's settings (see "Using Samsung Printer Status" on page 312 or "Using Samsung Easy Printer Manager" on page 309).
- Samsung Easy Document Creator is an application to help users scan, compile, and save documents in multiple formats, including .epub format. These documents can be shared via social networking sites or fax (see "Using Samsung Easy Document Creator" on page 305).

# Key benefits

- Smart Update allows you to check for the latest software and install the latest version during the printer driver installation process. This is available only for Windows.
- If you have Internet access, you can get help, support application, machine drivers, manuals, and order information from the Samsung website, [www.samsung.com](http://www.samsung.com) > find your product > Support or Downloads.

## Wide range of functionality and application support



- Supports various paper sizes (see "Print media specifications" on page 132).
- Print watermark: You can customize your documents with words, such as "**Confidential**" (see "Using advanced print features" on page 261).
- You can print in various operating systems (see "System requirements" on page 136).
- Your machine is equipped with a USB interface and/or a network interface.

## Supports various wireless network setting method



- Using the WPS (Wi-Fi Protected Setup™)
  - You can easily connect to a wireless network using the WPS menu on the machine and the access point (a wireless router).
- Using the USB cable or a network cable
  - You can connect and set various wireless network settings using a USB cable or a network cable.
- Using the Wi-Fi Direct
  - You can conveniently print from your mobile device using the Wi-Fi or Wi-Fi Direct feature.



See "Wireless network setup" on page 176.

# Features by model

Some features and optional goods may not be available depending on model or country.

## Operating System

Operating System	C306xND series	C306xFR series	C306xFW series
Windows	●	●	●
Mac	●	●	●
Linux	●	●	●
Unix	●	●	●

(●: Supported, Blank: Not supported)

## Software

You can install the printer driver and software when you insert the software CD into your CD-ROM drive. For windows, select the printer driver and software in the **Select Software to Install** window.

Software	C306xND series	C306xFR series	C306xFW series
<b>SPL printer driver</b>	●	●	●
<b>PCL printer driver</b>	●	●	●
<b>PS printer driver<sup>a</sup></b>	●	●	●
<b>XPS printer driver<sup>a</sup></b>	●	●	●
<b>Direct Printing Utility<sup>a</sup></b>	●	●	●
<b>Samsung Printer Center</b>	●	●	●

Software		C306xND series	C306xFR series	C306xFW series
<b>Samsung Easy Printer Manager</b>	<b>Scan to PC Settings</b>	●	●	●
	<b>Fax to PC Settings</b>		●	●
	<b>Advanced Setting</b>	●	●	●
<b>Samsung Printer Status</b>		●	●	●
<b>Samsung AnyWeb Print<sup>a</sup></b>		●	●	●
<b>Samsung Easy Document Creator</b>		●	●	●
<b>Easy Capture Manager</b>		●	●	●
<b>Samsung Eco Driver Pack<sup>b</sup></b>		●	●	●
<b>Samsung Stylish Driver Pack<sup>c</sup></b>		●	●	●
<b>SyncThru™ Web Service</b>		●	●	●
<b>Fax</b>	<b>Samsung Network PC Fax</b>		●	●
<b>Scan</b>	<b>Scan driver</b>	●	●	●

- Download the software from the Samsung website and install it: (<http://www.samsung.com> > find your product > Support or Downloads). Before installing, check whether your computer's OS support the software.
- To use the Easy Eco Driver features, the **Eco Driver Pack** must be installed.
- The printer driver includes a user interface that is optimized for touchscreens. To use this UI, click **Samsung Printer Center** > **Device Options** and then select **Stylish User Interface** (see "Using Samsung Printer Center" on page 306).

(●: Supported, Blank: Not supported)

# Features by model

## Variety feature

Features	C306xND series	C306xFR series	C306xFW series
Hi-Speed USB 2.0	●	●	●
Network Interface Ethernet 10/100/1000 Base TX wired LAN	●	●	●
Network Interface 802.11b/g/n wireless LAN <sup>a</sup>	○	○	●
NFC (Near Field Communication)	○	○	●
Google Cloud Print™	●	●	●
Samsung Cloud Print	●	●	●
PrinterOn	●	●	●
Mopria	●	●	●
Eco printing	●	●	●
Duplex (2-sided) printing	●	●	●
USB memory interface	●	●	●
Optional tray (Tray2, Tray3)	○	○	○

Features		C306xND series	C306xFR series	C306xFW series
Document Feeder	Automatic Document Feeder (ADF)	●		
	Reversing Automatic Document Feeder (RADF)		●	●

a. Depending on your country, wireless LAN card may not be available. For some countries, only 802.11 b/g can be applied. Contact your local Samsung dealer or the retailer where you bought your machine.

(●: Supported, ○: Optional, Blank: Not supported)

# Useful to know



## The machine does not print.

- Open the print queue list and remove the document from the list (see "Canceling a print job" on page 58).
- Remove the driver and install it again (see "Installing the driver locally" on page 24).
- Select your machine as your default machine in your Windows (see "Setting your machine as a default machine" on page 261).



## Where can I purchase accessories or supplies?

- Inquire at a Samsung distributor or your retailer.
- Visit [www.samsung.com/supplies](http://www.samsung.com/supplies). Select your country/region to view product service information.



## The status LED flashes or remains constantly on.

- Turn the product off and on again.
- Check the meanings of LED indications in this manual and troubleshoot accordingly (see "Understanding the status LED" on page 120).



## A paper jam has occurred.

- Open and close the cover (see "Front view" on page 18).
- Check the instructions on removing jammed paper in this manual and troubleshoot accordingly (see "Clearing paper jams" on page 107).



## Printouts are blurry.

- The toner level might be low or uneven. Shake the toner cartridge (see "Redistributing toner" on page 87).
- Try a different print resolution setting (see "Opening printing preferences" on page 59).
- Replace the toner cartridge (see "Replacing the toner cartridge" on page 89).



## Where can I download the machine's driver?

- You can get help, support application, machine drivers, manuals, and order information from the Samsung website, [www.samsung.com](http://www.samsung.com) > find your product > Support or Downloads.

# About this user guide

This user guide provides information for your basic understanding of the machine as well as detailed steps to explain machine usage.



- Do not discard this manual, and keep it for future reference.
- Read the safety information before using the machine.
- If you have a problem using the machine, refer to the troubleshooting chapter.
- Terms used in this user guide are explained in the glossary chapter.
- All illustrations in this user guide may differ from your machine depending on its options or model you purchased.
- The screenshots in this user guide may differ from your machine depending on the machine's firmware/driver version.
- The procedures in this user guide are mainly based on Windows 7.

## Conventions

Some terms in this guide are used interchangeably, as below:

- Document is synonymous with original.
- Paper is synonymous with media, or print media.
- Machine refers to printer or MFP.

## General icons



Icon	Text	Description
	<b>Warning</b>	Used to alert users to the possibility of personal injury.
	<b>Caution</b>	Gives users information to protect the machine from possible mechanical damage or malfunction.
	<b>Note</b>	Provides additional information or detailed specification of the machine function and feature.

# Safety information

These warnings and precautions are included to prevent injury to you and others, and to prevent any potential damage to your machine. Be sure to read and understand all of these instructions before using the machine. After reading this section, keep it in a safe place for future reference.

## Important safety symbols

### Explanation of all icons and signs used in this chapter

	<b>Warning</b>	Hazards or unsafe practices that may result in severe personal injury or death.
	<b>Caution</b>	Hazards or unsafe practices that may result in minor personal injury or property damage.
		Do not attempt.

## Operating environment

### Warning



Do not use if the power cord is damaged or if the electrical outlet is not grounded.

This could result in electric shock or fire.



Do not place anything on top of the machine (water, small metal or heavy objects, candles, lit cigarettes, etc.).

This could result in electric shock or fire.

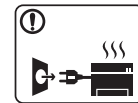

- If the machine gets overheated, it releases smoke, makes strange noises, or generates an odd odor, immediately turn off the power switch and unplug the machine.

- The user should be able to access the power outlet in case of emergencies that might require the user to pull the plug out.

This could result in electric shock or fire.



Do not bend, or place heavy objects on the power cord.

Stepping on or allowing the power cord to be crushed by a heavy object could result in electric shock or fire.







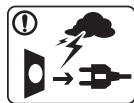

Do not remove the plug by pulling on the cord; do not handle the plug with wet hands.

This could result in electric shock or fire.







# Safety information

## Caution

	<p>During an electrical storm or for a period of non-operation, remove the power plug from the electrical outlet.</p> <p>This could result in electric shock or fire.</p>
	<p>Be careful, the paper output area is hot.</p> <p>Burns could occur.</p>
	<p>If the machine has been dropped, or if the cabinet appears damaged, unplug the machine from all interface connections and request assistance from qualified service personnel.</p> <p>Otherwise, this could result in electric shock or fire.</p>
	<p>If the machine does not operate properly after these instructions have been followed, unplug the machine from all interface connections and request assistance from qualified service personnel.</p> <p>Otherwise, this could result in electric shock or fire.</p>
	<p>If the plug does not easily enter the electrical outlet, do not attempt to force it in.</p> <p>Call an electrician to change the electrical outlet, or this could result in electric shock.</p>
	<p>Do not allow pets to chew on the AC power, telephone or PC interface cords.</p> <p>This could result in electric shock or fire and/or injury to your pet.</p>

## Operating method

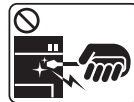
### Caution

	<p>Do not forcefully pull the paper out during printing.</p> <p>It can cause damage to the machine.</p>
	<p>Be careful not to put your hand between the machine and paper tray.</p> <p>You may get injured.</p>
	<p>Be careful when replacing paper or removing jammed paper.</p> <p>New paper has sharp edges and can cause painful cuts.</p>
	<p>When printing large quantities, the bottom part of the paper output area may get hot. Do not allow children to touch.</p> <p>Burns can occur.</p>
	<p>When removing jammed paper, do not use tweezers or sharp metal objects.</p> <p>It can damage the machine.</p>
	<p>Do not allow too many papers to stack up in the paper output tray.</p> <p>It can damage the machine.</p>



# Safety information



Do not block or push objects into the ventilation opening.  
This could result in elevated component temperatures which can cause damage or fire.



Use of controls or adjustments or performance of procedures other than those specified herein may result in hazardous radiation exposure.



This machine's power reception device is the power cord.  
To switch off the power supply, remove the power cord from the electrical outlet.

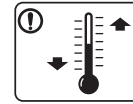

Place the machine in the environment where it meets the operating temperature and humidity specification.

Do not use the machine when it is below freezing temperature or has recently been moved from a location below freezing temperature. Doing so may damage the machine. Only operate the machine when the internal temperature of the machine is within the operating temperature and humidity specifications.

Otherwise, quality problems can occur and cause damage to the machine.

See "General specifications" on page 130.

## Installation / Moving

### Warning



Do not place the machine in an area with dust, humidity, or water leaks.

This could result in electric shock or fire.

# Safety information

## Caution



Before moving the machine, turn the power off and disconnect all cords. The information below are only suggestions based on the units weight.

If you have a medical condition that prevents you from lifting, do not lift the machine. Ask for help, and always use the appropriate amount of people to lift the device safely.

Then lift the machine:

- If the machine weighs under 20 kg (44.09 lbs), lift with 1 person.
- If the machine weighs 20 kg (44.09 lbs) - 40 kg (88.18 lbs), lift with 2 people.
- If the machine weighs more than 40 kg (88.18 lbs), lift with 4 or more people.

The machine could fall, causing injury or machine damage.

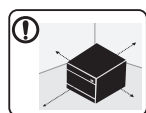

Choose a flat surface with enough space for ventilation to place the machine. Also consider the space required to open the cover and trays.

The place should be well-ventilated and be far from direct light, heat, and humidity.



When using the machine for a long period of time or printing a large number of pages in a non-ventilated space, it could pollute the air and be harmful to your health. Place the machine in a well-ventilated space or open a window to circulate the air periodically.



Do not place the machine on an unstable surface.  
The machine could fall, causing injury or machine damage.



Use only No.26 AWG<sup>a</sup> or larger, telephone line cord, if necessary.  
Otherwise, it can cause damage to the machine.



Make sure you plug the power cord into a grounded electrical outlet.  
Otherwise, this could result in electric shock or fire.



Use the power cord supplied with your machine for safe operation. If you are using a cord which is longer than 2 meters (6 feet) with a 110V machine, then the gauge should be 16 AWG or larger.  
Otherwise, it can cause damage to the machine, and could result in electric shock or fire.



Do not put a cover over the machine or place it in an airtight location, such as a closet.  
If the machine is not well-ventilated, this could result in fire.



Do not overload wall outlets and extension cords.  
This can diminish performance, and could result in electric shock or fire.



The machine should be connected to the power level which is specified on the label.  
If you are unsure and want to check the power level you are using, contact the electrical utility company.

a. AWG: American Wire Gauge

# Safety information

## Maintenance / Checking

### Caution



Unplug this product from the wall outlet before cleaning the inside of the machine. Do not clean the machine with benzene, paint thinner or alcohol; do not spray water directly into the machine.

This could result in electric shock or fire.



When you are working inside the machine replacing supplies or cleaning the inside, do not operate the machine.

You could get injured.



Keep cleaning supplies away from children.

Children could get hurt.



Do not disassemble, repair or rebuild the machine by yourself. It can damage the machine. Call a certified technician when the machine needs repairing.



To clean and operate the machine, strictly follow the user's guide provided with the machine.

Otherwise, you could damage the machine.



Keep the power cable and the contact surface of the plug clean from dust or water.

Otherwise, this could result in electric shock or fire.



- Do not remove any covers or guards that are fastened with screws.
- Fuser units should only be repaired by a certified service technician. Repair by non-certified technicians could result in fire or electric shock.
- The machine should only be repaired by a Samsung service technician.

## Supply usage

### Caution



Do not disassemble the toner cartridge.





Toner dust can be dangerous if inhaled or ingested.



Do not burn any of the supplies such as toner cartridge or fuser unit.

This could cause an explosion or uncontrollable fire.



# Safety information

	<p>When storing supplies such as toner cartridges, keep them away from children.</p> <p>Toner dust can be dangerous if inhaled or ingested.</p>
	<p>Using recycled supplies, such as toner, can cause damage to the machine.</p> <p>In case of damage due to the use of recycled supplies, a service fee will be charged.</p>
	<p>For supplies that contain toner dust (toner cartridge, waste toner bottle, imaging unit, etc.) follow the instructions below.</p> <ul style="list-style-type: none"><li>• When disposing of the supplies, follow the instructions for disposal. Refer to the reseller for disposal instructions.</li><li>• Do not wash the supplies.</li><li>• For a waste toner bottle, do not reuse it after emptying the bottle.</li></ul> <p>If you do not follow the instructions above, it may cause machine malfunction and environmental pollution. The warranty does not cover damages caused by a user's carelessness.</p>
	<p>When toner gets on your clothing, do not use hot water to wash it.</p> <p>Hot water sets toner into fabric. Use cold water.</p>
	<p>When changing the toner cartridge or removing jammed paper, be careful not to let toner dust touch your body or clothes.</p> <p>Toner dust can be dangerous if inhaled or ingested.</p>

# Machine overview

## Components

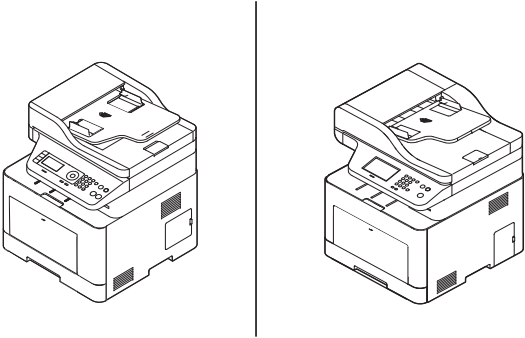
The actual component may differ from the illustration below. Some components may change depending on the configuration.

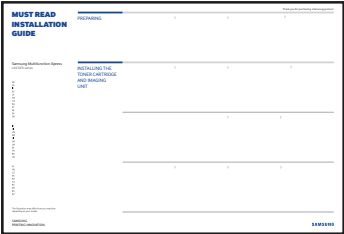
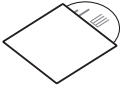
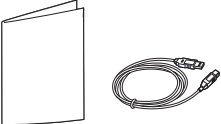
		
Machine <sup>a</sup>	Power cord	Quick installation guide
		
Software CD <sup>b</sup>	Misc. accessories <sup>c</sup>	

a. This illustration may differ from your machine depending on your model. There are various types of machine.

b. The software CD contains the print drivers, user's guide, and software applications.

c. Miscellaneous accessories included with your machine may vary by country of purchase and specific model.

# Machine overview

## Front view



- This illustration may differ from your machine depending on your model. There are various types of machine.
- Some features and optional goods may not be available depending on model or country (see "Features by model" on page 7).

## C306xND series

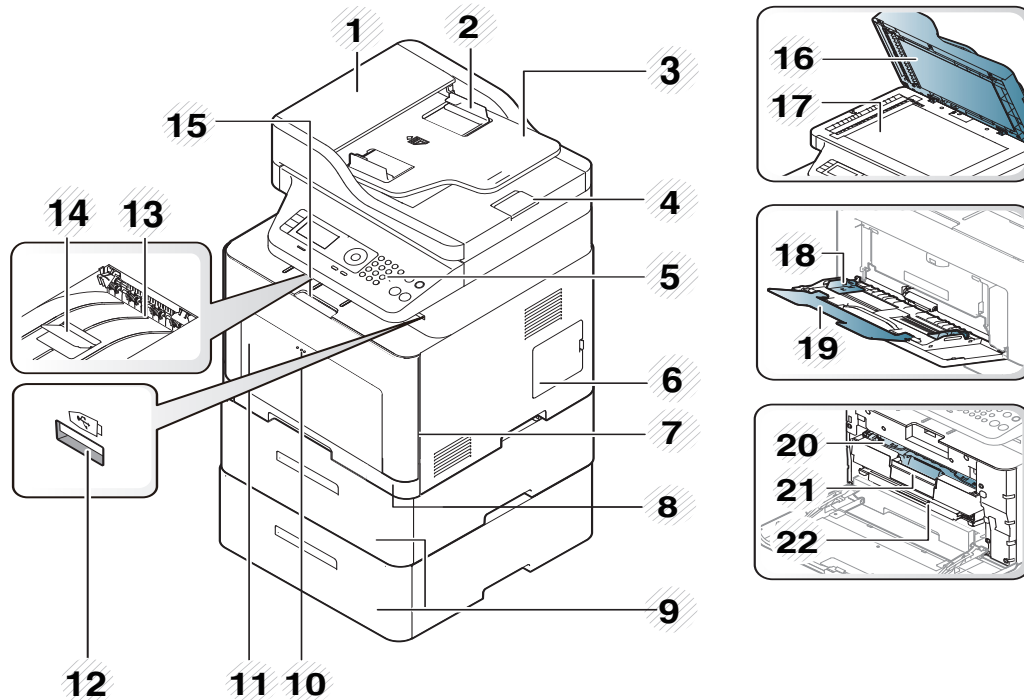

1	Automatic Document Feeder (ADF) cover	12	USB memory port
2	Automatic Document Feeder (ADF) width guide	13	Output tray
3	Automatic Document Feeder (ADF) input tray	14	Output support tray
4	Automatic Document Feeder (ADF) output tray	15	Front cover handle
5	Control panel	16	Scanner lid
6	Control board cover	17	Scanner glass
7	Front cover	18	Paper width guides on a multi-purpose tray
8	Tray 1	19	Multi-purpose support tray
9	Optional tray <sup>a</sup>	20	Toner cartridges
10	Push-release of Multi-purpose tray	21	Toner cartridge handle
11	Multi-purpose tray	22	Intermediate Transfer Belt (ITB)

a. Install the optional tray if it is necessary.

# Machine overview

## C306xFR series/ C306xFW series

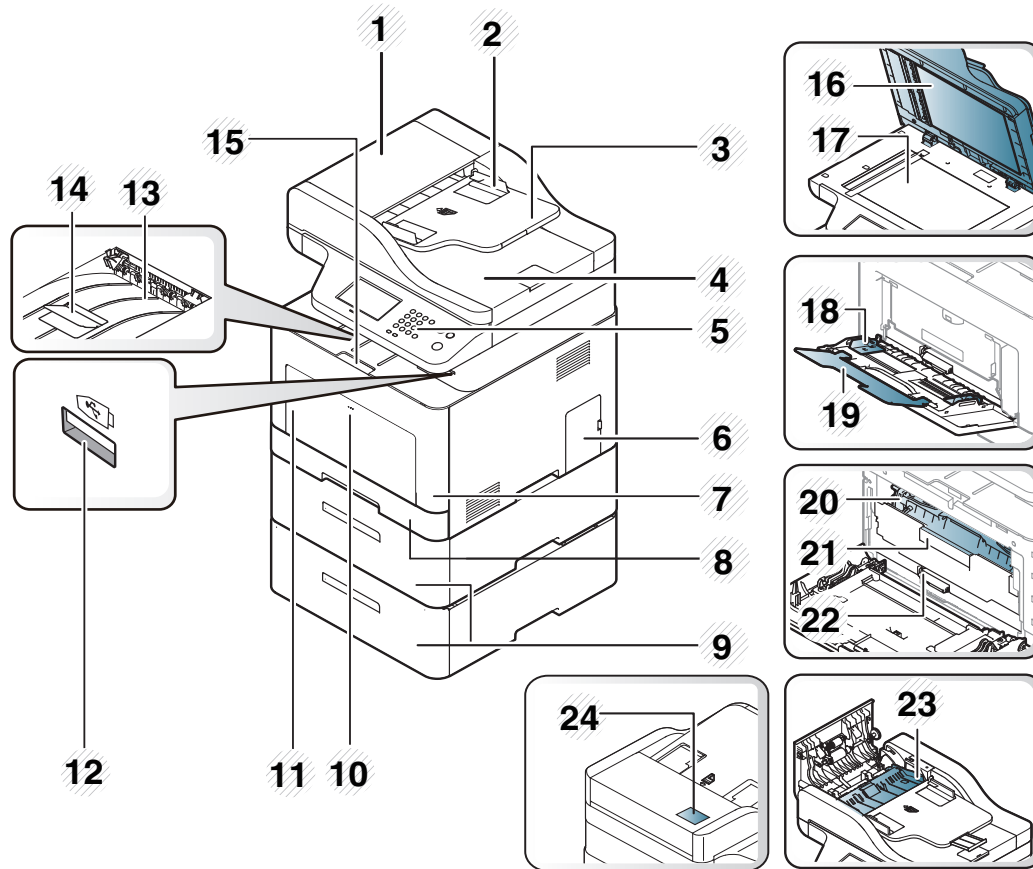

1	Reversing Automatic Document Feeder (RADF)	13	Output tray
2	Reversing Automatic Document Feeder (RADF) width guide	14	Output support tray
3	Reversing Automatic Document Feeder (RADF) input tray	15	Front cover handle
4	Reversing Automatic Document Feeder (RADF) output tray	16	Scanner lid
5	Control panel	17	Scanner glass
6	Control board cover	18	Paper width guides on a multi-purpose tray
7	Front cover	19	Multi-purpose support tray
8	Tray 1	20	Toner cartridges
9	Optional tray <sup>a</sup>	21	Toner cartridge handle
10	Push-release of Multi-purpose tray	22	Intermediate Transfer Belt (ITB)
11	Multi-purpose tray	23	Duplex jam cover
12	USB memory port	24	NFC (Near Field Communication) tag <sup>b</sup>

a. Install the optional tray if it is necessary.

b. C306xFW only.

# Machine overview

## Rear view



- This illustration may differ from your machine depending on your model. There are various types of machine.
- Some features and optional goods may not be available depending on model or country (see "Features by model" on page 7).

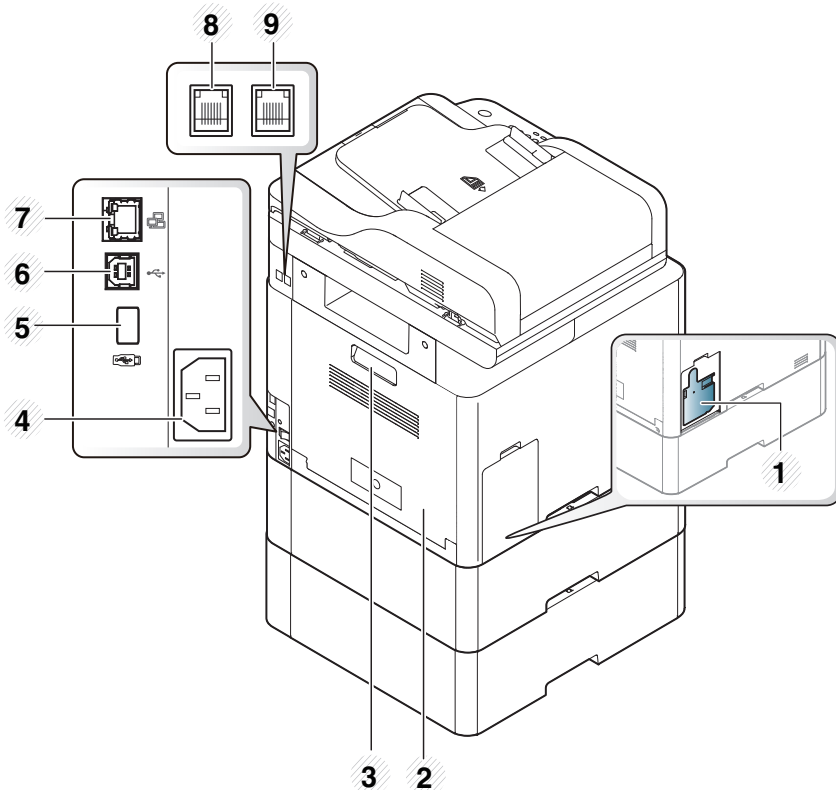

1	Waste toner container
2	Rear cover
3	Rear cover handle
4	Power receptacle
5	USB memory port
6	USB port
7	Network port
8	Telephone line socket ( <b>LINE</b> ) <sup>a</sup>
9	Extension telephone socket ( <b>EXT.</b> ) <sup>a</sup>

a. C306xFR and C306xFW only.



# Control panel overview







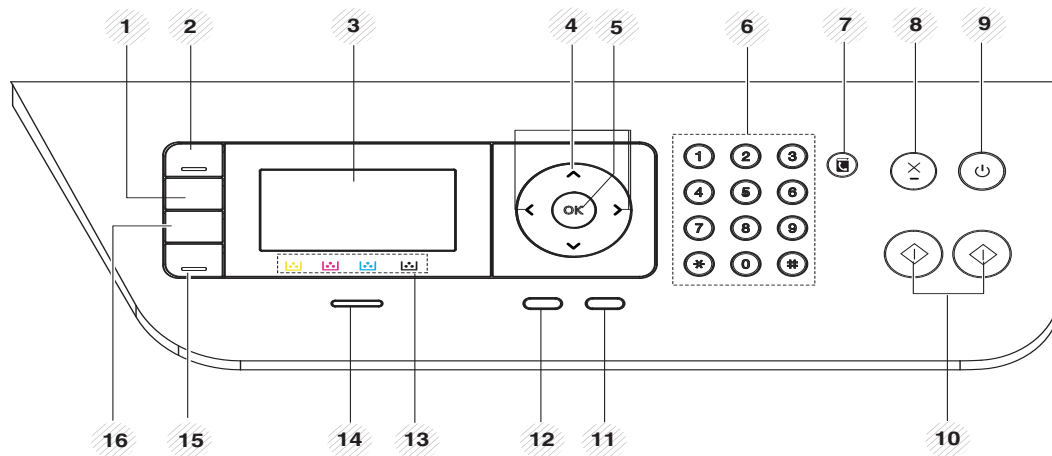

- This control panel may differ from your machine depending on its model. There are various types of control panels.
- Some features and optional goods may not be available depending on model or country (see "Features by model" on page 7).

## C306xND series





1	<b>Darkness</b>	Adjusts the brightness level to make a copy for easier reading, when the original contains faint markings and dark images.
2	<b>Scan to</b>	Sends scanned data.
3	<b>Display screen</b>	Shows the current status and prompts during an operation.
4	<b>Arrows</b>	Scroll through the options available in the selected menu, and increase or decrease values.





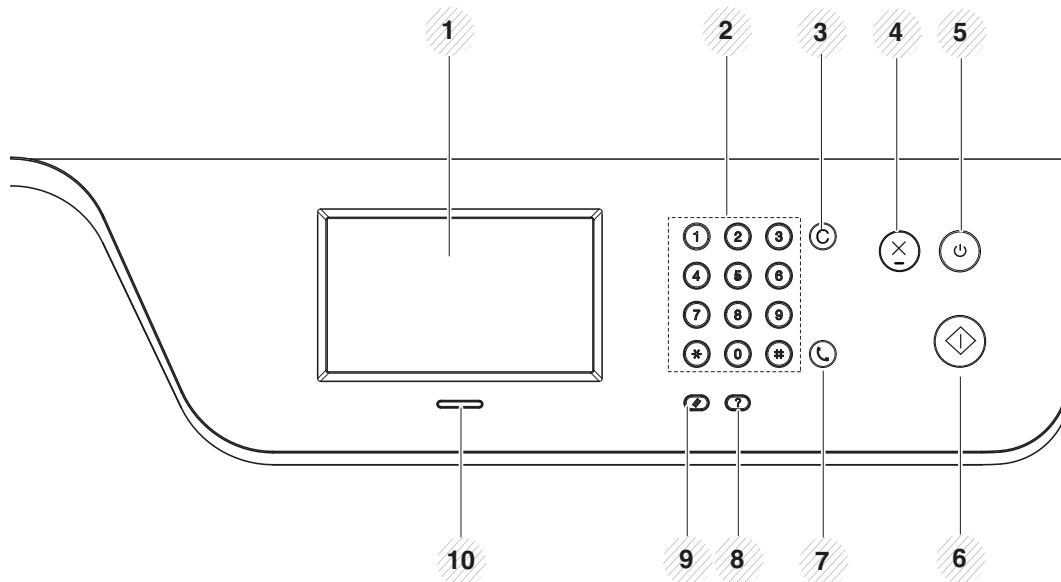

5	<b>OK</b>	Confirms the selection on the screen.
6	<b>Numeric keypad</b>	Dials a number or enters alphanumeric characters (see "Understanding keypad" on page 253).
7	<b>Address Book</b>	 Allows you to store frequently used email address or search for stored email address (see "Storing email address" on page 251 ).
8	<b>Stop/Clear</b>	 Stops current operation.
9	<b>Power/Wakeup</b>	 Turns the power on or off, or wakes up the machine from the power save mode. If you need to turn the machine off, press this button for more than three seconds.
10	<b>Start</b>	
	<b>Color</b>	 Begins a printing job in color mode.
	<b>Black</b>	 Begins a printing job in black and white mode.
11	<b>Back</b>	Sends you back to the upper menu level.
12	<b>Menu</b>	 Enters Menu mode and scrolls through the available menus (see "Menu overview" on page 28).
13	<b>Toner colors</b>	Show the status of each toner cartridge (see "Toner-related messages" on page 123).
14	<b>Status LED</b>	Indicates the status of your machine (see "Understanding the status LED" on page 120).
15	<b>Eco</b>	Turn into eco mode to reduce toner consumption and paper usage when pc-printing and copying only (see "Eco printing" on page 61).
16	<b>Direct USB</b>	Allows you to directly print files stored on a USB memory device when it is inserted into the USB port on the front of your machine.

# Control panel overview

## C306xFR series / C306xFW series



1	<b>Display screen</b>	Shows the current status and displays prompts during an operation.
2	<b>Numeric keypad</b>	Dials a number or enters alphanumeric characters (see "Understanding keypad" on page 253).
3	<b>Clear</b>	<b>C</b> Deletes characters in the edit area.
4	<b>Stop</b>	 Stops an operations at any time.

5	<b>Power/ Wakeup</b>	 Turns the power on or off, or wakes up the machine from the power save mode. If you need to turn the machine off, press this button for more than three seconds.
6	<b>Start</b>	 Starts a job in black or color mode.
7	<b>On Hook Dial</b>	 When you press  ( <b>Fax</b> ) > <b>On Hook Dial</b> > <b>On Hook</b> on the Home screen, you can hear the dial tone. Then, enter the fax number. This process is similar to making a call using a speaker phone (see "Receiving manually in Tel mode" on page 291).
8	<b>Help</b>	 Gives detailed information about this machine's menus or status.
9	<b>Reset</b>	 Resets the current machine's setup.
10	<b>Status LED</b>	Indicates the status of your machine (see "Understanding the status LED" on page 120).



When you use the touch screen, use your finger only. The screen may be damaged with a sharp pen or anything else.

# Turning on the machine



Illustrations on this user's guide may differ from your machine depending on its options or models. Check your machine type (see "Front view" on page 18).



- Keep in mind that you should use the power cord supplied with the machine. Otherwise, it can cause damage or fire to the machine.
- Some parts inside of the machine may be hot when power is on, or after printing. Be careful not to burn yourself when working inside the machine.
- Do not disassemble the machine when it is turned on or plugged in. Doing so may give you an electric shock.

**1** Connect the machine to the electricity supply first.

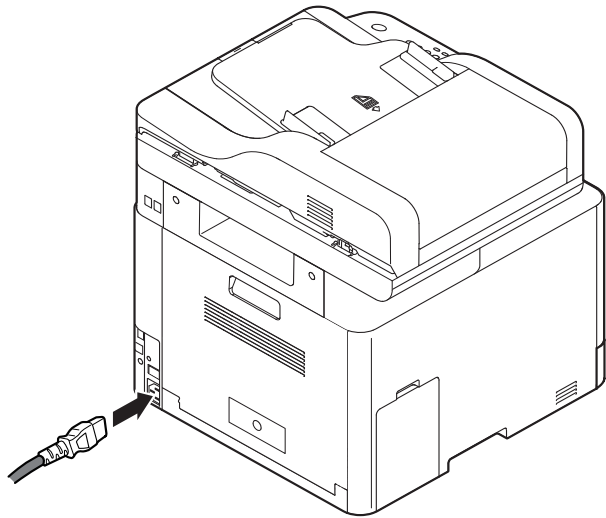

**2**

Power is turned on automatically.



You can also turn the machine on pressing the  (**Power/Wakeup**) button.

# Installing the driver locally

A locally connected machine is a machine directly attached to your computer using the USB cable. If your machine is attached to a network, skip the following steps below and go on to installing a network connected machine's driver (see "Installing driver over the network" on page 169).



- If you are a Mac, Linux or UNIX operating systems user, refer to the "Installation for Mac" on page 158 or "Installation for Linux" on page 160 or "Installing the UNIX printer driver package" on page 174.
- The installation window in this User's Guide may differ depending on the machine and interface in use.
- Only use a USB cable no longer than 3 meters (118 inches).

## Windows

- 1 Make sure that the machine is connected to your computer and powered on.
- 2 Insert the supplied software CD into your CD-ROM drive.



If the installation window does not appear, click **Start > All programs > Accessories > Run**.

X:\**Setup.exe** replacing "X" with the letter, which represents your CD-ROM drive and click **OK**.

- For Windows 8

If the installation window does not appear, from **Charms**, select **Search > Apps** and search for **Run**. Type in X:\**Setup.exe**, replacing "X" with the letter that represents your CD-ROM drive and click **OK**.

If "**Tap to choose what happens with this disc.**" pop-up window appears, click the window and select **Run Setup.exe**.

- For Windows 10 / Windows Server 2016

If the installation window does not appear, from task bar, type in X:\**Setup.exe** in **Search** input area, replacing "X" with the letter that represents your CD-ROM drive and press the Enter key.

- 3 Review and accept the installation agreements in the installation window, and then click **Next**.
- 4 Select **USB** on the **Printer Connection Type** screen, and then click **Next**.
- 5 Follow the instructions in the installation window.

# Installing the driver locally

## From the Windows 8 Start Screen



- The V4 driver is automatically downloaded from the Windows Update if your computer is connected to the Internet. Or, you can manually download the V4 driver from Samsung website, [www.samsung.com](http://www.samsung.com) > find your product > Support or downloads.
- You can download Samsung Printer Experience app from the Windows Store. You need have a Microsoft account to use the Windows Store.
  - 1 From **Charms**, select **Search**.
  - 2 Click **Store**.
  - 3 Search and click **Samsung Printer Experience**.
  - 4 Click **Install**.
- If you install the driver using the supplied software CD, V4 driver is not installed. If you want to use the V4 driver in the **Desktop** screen, you can download from the Samsung website, [www.samsung.com](http://www.samsung.com) > find your product > Support or downloads.
- If you want to install Samsung's printer management tools, you need to install them using the supplied software CD.

- 1 Make sure that your computer is connected to the Internet and powered on.
- 2 Make sure that the machine is powered on.
- 3 Connect the computer and the machine with a USB cable.  
The driver is automatically installed from the **Windows Update**.

# Reinstalling the driver

If the printer driver does not work properly, follow the steps below to reinstall the driver.

## Windows

- 1 Make sure that the machine is connected to your computer and powered on.
- 2 From the **Start** menu, select **Programs** or **All Programs** > **Samsung Printers** > **Uninstall Samsung Printer Software** .
  - For Windows 8,
    - 1 From Charms, select **Search** > **Apps**.
    - 2 Search and click **Control Panel**.
    - 3 Click **Programs and Features**.
    - 4 Right-click the driver you want to uninstall and select **Uninstall**.
  - For Windows 10 / Windows Server 2016
    - 1 From task bar, type in **Programs and Features** in **Search** input area. Press the Enter key.  
OR  
From the **Start** (  ) icon, select **All apps** > **Search** > type in **Programs and Features**.
    - 2 Right-click the driver you want to uninstall and select **Uninstall**.
- 3 Follow the instructions in the installation window.
- 4 Insert the software CD into your CD-ROM drive and install the driver again (see "Installing the driver locally" on page 24).

## From the Windows 8 Start Screen

- 1 Make sure that the machine is connected to your computer and powered on.
- 2 Click on the **Uninstall Samsung Printer Software** tile in the **Start** screen.
- 3 Follow the instructions in the window.



- If you cannot find a Samsung Printer Software tile, uninstall from the desktop screen mode.
- If you want to uninstall Samsung's printer management tools, from the **Start** screen, right-click the app > **Uninstall** > right-click the program you want to delete > **Uninstall** and follow the instruction in the window.



## 2. Menu Overview and Basic Setup

This chapter provides information about the overall menu structure and the basic setup options.

- **Menu overview** 28
- **Machine's basic settings** 41
- **Media and tray** 42
- **Basic printing** 57
- **Basic copying** 64
- **Basic scanning** 69
- **Basic faxing** 70
- **Using USB memory device** 74

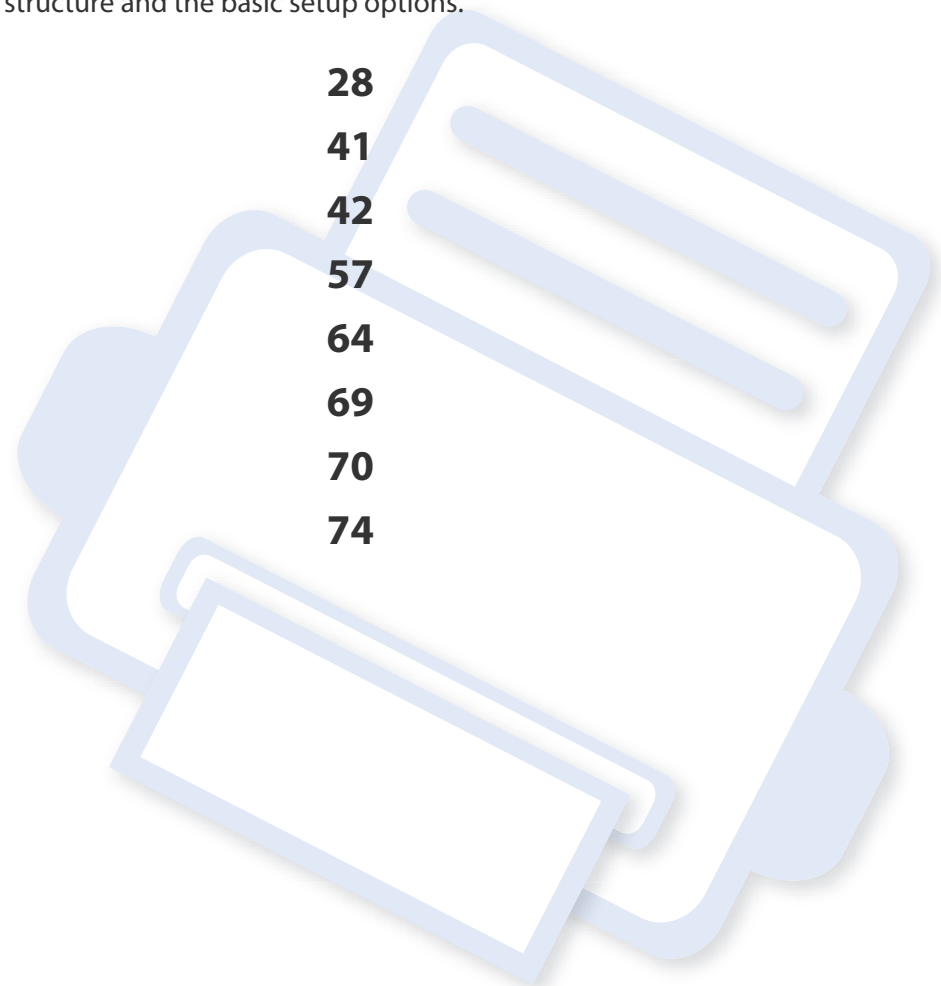

# Menu overview



The control panel provides access to various menus to set up the machine or use the machine's functions.



- Some menus may not appear on the display depending on options or models. If so, it is not applicable to your machine.
- Some menu names may differ from your machine depending on its options or the models.
- The menus are described in the Advanced Guide (see "Useful Setting Menus" on page 211).

## C306xND series

### Accessing the menu

- 1 Select  (**Menu**) until the menu you want appears on the bottom line of the display and press **OK**.
- 2 Press the arrows until the needed menu item appears and press **OK**.
- 3 If the setting item has sub menus, repeat step 2.
- 4 Press **OK** to save the selection.
- 5 Press the  (**Stop/Clear** or **Stop**) button to return to the ready mode.



# Menu overview

Copy Feature (see "Copy feature" on page 215)			Copy Setup (see "Copy Setup" on page 220)	
<b>Original Size</b> <b>Reduce/Enlarge</b> <b>Duplex</b> 1->1 Sided 1->2 Sided 1->2 Sided, Rotated <b>Auto Color</b> <b>Darkness</b> Light+5- Light+1 Normal Dark+1- Dark+5 <b>Original Type</b> Text Text/Photo Photo Magazine	<b>Collation</b> <b>Layout</b> Normal 2-Up 4-Up ID Copy Book Copy <b>Adjust Background</b> Off Auto Enhance Lev.1 Enhance Lev.2 Erase Lev.1- Erase Lev.4 <b>Edge Erase</b> Off	<b>Small Original<sup>a</sup></b> <b>Hole Punch</b> <b>Book Center<sup>b</sup></b> <b>Border Erase</b> <b>Stamp</b> <b>WaterMark</b>	<b>Change Default</b> <b>Original Size</b> <b>Copies</b> <b>Reduce/Enlarge</b> <b>Duplex</b> 1->1 Sided 1->2 Sided 1->2 Sided, Rotated <b>Darkness</b> Light+5- Light+1 Normal Dark+1- Dark+5 <b>Auto Color</b>	<b>Original Type</b> <b>Text</b> <b>Text/Photo</b> <b>Photo</b> <b>Magazine</b> <b>Collation</b>

a. This option does not appear when the 2-Up, 4-Up, Book copy, Duplex, Auto Fit option is on or the original document is loaded in ADF or RADF.

b. This option appears only when the **Layout** option is **Book Copy**.

# Menu overview

Scan Feature <sup>a</sup> (see "Scan" on page 225)			Scan Setup <sup>a</sup> (see "Scan" on page 225)	Print Setup (see "Print" on page 213)	
<b>USB Feature</b>	<b>FTP Feature</b>	<b>Samsung Cloud</b>	<b>Change Default</b>	<b>Orientation</b>	<b>Edge Enhancement</b>
Original Size	Original Size	Original Size	USB Default	Portrait	Screen
Original Type	Original Type	Original Type	Email Default	Landscape	Trapping
Resolution	Resolution	Resolution	FTP/SMB Default	Duplex	Auto CR
Color Mode	Color Mode	Color Mode	Samsung Cloud	Off	Skip Blank Pages
Color	File Format	Darkness		Long Edge	Emulation
Gray	Darkness			Short Edge	Emulation Type
Mono	<b>SMB Feature</b>			Copies	Setup
File Format	Original Size			Resolution	
Darkness	Original Type			Standard	
<b>Email Feature</b>	Resolution			High Image Quality	
Original Size	Color Mode			Clear Text	
Original Type	File Format				
Resolution	Darkness				
Color Mode					
File Format					
Darkness					

a. This option appears only when you press the **Scan to** button on the control panel.

# Menu overview

## System Setup (see "System setup" on page 229)

Machine Setup	Auto Tray Switch	Paper Setup	Report	Maintenance
Date & Time	Paper Substitution	Paper Size	Configuration	CLR Empty Msg. <sup>c</sup>
Date Format	Tray Protection	Tray 1	Demo Page	Supplies Life
Clock Mode	Tray Mode	Tray 2 <sup>a</sup>	Network Configuration	Image Management
Language	PDF Type	Tray 3 <sup>a</sup>	Supplies Information	Custom Color
Default Mode	Eco Settings	MP Tray	Usage Counter	Auto Color Reg.
Power Save	Auto Power Off	Default Paper Size	Account <sup>b</sup>	Tone Adjustment
Wakeup Event	Quiet Mode	Paper Type	Email Sent	Serial Number
System Timeout	Stacking Mode	Paper Source	PCL Font	RAM Disk <sup>d</sup>
Job Timeout	Smart Duplex	Margin	PS Font	
Altitude Adjustment	Vapor Mode	Tray Confirmation	Address Book	
Humidity	Logout Confirmation			
Job Rescheduling				
Auto Continue				

a. This option is available when the optional tray is installed.

b. This option appears only if you have activated your account on the SyncThru™ Web Service (**Security** tab > **User Access Control** > **Accounting** > **Accounting Methods**).

c. This option only appears when small amount of toner is left in the cartridge.

d. Some menus may not appear on the display depending on options or models. If so, it is not applicable to your machine

# Menu overview

Network (see "Network setup" on page 239)		Job Management <sup>a</sup> (see "Job manage" on page 238)	PrinterOn <sup>b</sup> (see "PrinterOn" on page 248)	Admin Setup <sup>c</sup> (see "Admin setup" on page 242)	Direct USB <sup>d</sup> (see "Direct USB" on page 245)
TCP/IP (IPv4)	Wi-Fi Direct	Active Job		Stamp	USB Print
DHCP	Wi-Fi Signal	Secured Job		Item	File Manage
BOOTP	Clear Wi-Fi Settings	Stored Job		Text Size	Check Space
Static	Prototocol Management			Opacity	
TCP/IP (IPv6)	NFC <sup>e</sup>			Position	
IPv6 Protocol	Network Configuration			Change Admin Password	
DHCPv6 Config	Clear Settings			Firmware Upgrade	
Ethernet				Import Setting	
Ethernet Port				Export Setting	
Ethernet Speed				Secure Print	
802.1x				Supplies Management	
Wi-Fi <sup>e</sup>				Coverage Counter	
Wi-Fi On/Off					
Wi-Fi Settings					
WPS					

a. This is used only available when **System Setup > Ram Disk** is enabled.

b. This is used only available when **PrinterOn** is enabled. The sub menus that appear in this menu may differ based on whether or not the machine is connected to the **PrinterOn** server.

c. ] You need to enter a password to enter this menu. The default password is **sec00000**.

d. This option appears only when you press the **Direct USB** button on the control panel. You can enter the USB menu when USB memory is inserted into the USB memory port on your machine.

e. This option is available when the optional Wireless/NFC kit is installed.

# Menu overview

## C306xFR series / C306xFW series









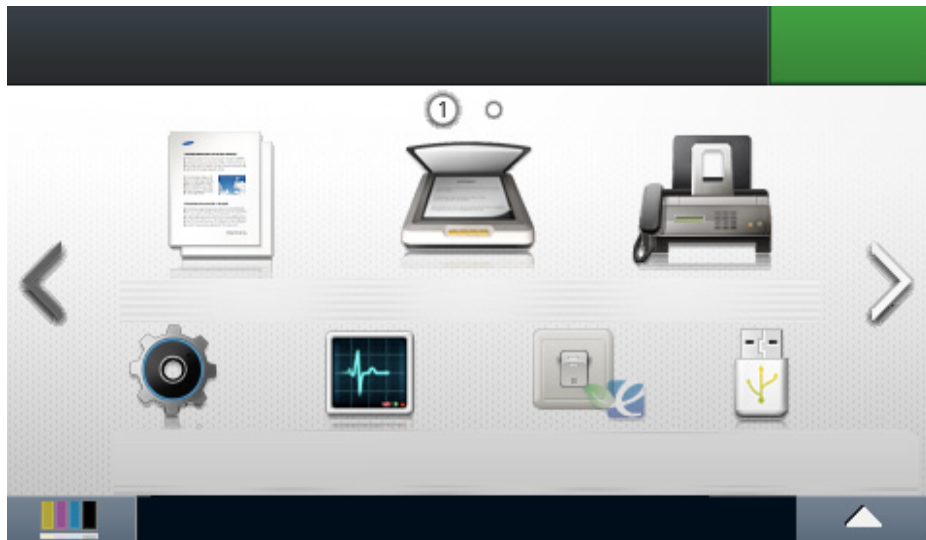





You can set menus easily using the touch screen.



- The **Main** screen is shown on the touch screen on the control panel.
- Some menus are grayed out depending on your options or models.
- Some menu names may differ from your machine depending on its options or the models.

## Introducing the Home Screen



<b>Copy</b>		When you press <b>Copy</b> from the display screen, the Copy screen appears which has several tabs and lots of copying options.
<b>Scan</b>		When you press <b>Scan</b> from the display screen, the Scan screen appears which has several tabs and lots of Scanning options.
<b>Fax</b>		When you press <b>Fax</b> from the display screen, the Fax screen appears which has several tabs and lots of Faxing options.
<b>Setup</b>		You can browse current machine settings or change machine values.
<b>Job Status</b>		You can see the jobs currently running, completed job or in queue.
<b>Eco</b>		You can view the eco settings.
<b>Direct USB</b>		You can enter the USB menu when USB memory is inserted into the USB memory port on your machine.
<b>Document Box</b>		You can store the printing data, print the secure page or shared folder.
<b>PrinterOn</b>		You can print in the cloud service.
<b>Option Settings</b>		You want to customize the option settings including darkness, original type, and more.
<b>Toner Status</b>		You can see the toner status.
<b>Arrows</b>		You can scroll through the options available in the selected menu, and increase or decrease values.
<b>Back</b>		You can go back to the previous screen.
		You can select the QR code, language, LCD brightness, and you can edit home menu.

# Menu overview



Copy (see "Copy" on page 215)

Basic Copy	Custom Copy	Edge Erase	ID Copy	N-Up Copy	Book Copy
(Option settings)	(Option settings)	<b>Off</b>	(Option settings)	(Option settings)	(Option settings)
<b>Darkness</b>	<b>Duplex</b>	<b>Small Original</b>	<b>Darkness</b>	<b>N-Up</b>	<b>Book Copy</b>
<b>Color Mode</b>	<b>Reduce/Enlarge</b>	<b>Hole Punch</b>	<b>Color Mode</b>	<b>Original Orientation</b>	<b>Darkness</b>
<b>Color</b>	<b>Darkness</b>	<b>Book Center<sup>a</sup></b>	<b>Original Type</b>	<b>Duplex</b>	<b>Color Mode</b>
<b>Mono</b>	<b>Color Mode</b>	<b>Border Erase</b>	<b>Auto Fit Copy</b>	<b>Darkness</b>	<b>Original Size</b>
<b>Auto</b>	<b>Original Size</b>	<b>Stamp</b>	(Option settings)	<b>Color Mode</b>	<b>Original Type</b>
<b>Original Type</b>	<b>Original Type</b>	<b>Stamp Activate</b>	<b>Darkness</b>	<b>Original Size</b>	
<b>Text</b>	<b>Paper Source</b>	<b>Item</b>	<b>Color Mode</b>	<b>Original Type</b>	
<b>Text/Photo</b>	<b>Collation</b>	<b>Text Size</b>	<b>Original Type</b>		
<b>Photo</b>	<b>Layout</b>	<b>Opacity</b>			
<b>Magazine</b>	<b>Normal</b>	<b>Position</b>			
	<b>2-Up</b>	<b>Watermark</b>			
	<b>4-Up</b>				
	<b>ID Copy</b>				
	<b>Book Copy</b>				
	<b>Adjust Background</b>				

a. This option appears only when the **Layout** option is **Book Copy**.

# Menu overview



Scan (see "Scan" on page 225)

Samsung Cloud	Local PC	Network PC	Email	SMB
<b>Destination</b>	<b>Destination</b>	<b>Destination</b>	<b>To</b>	<b>Destination</b>
(Option settings)	(Option settings)	(Option settings)	(Option settings)	(Option settings)
<b>Original Size</b>	<b>Original Size</b>	<b>Original Size</b>	<b>Original Size</b>	<b>Original Size</b>
<b>Original Type</b>	<b>Original Type</b>	<b>Original Type</b>	<b>Original Type</b>	<b>Original Type</b>
<b>Resolution</b>	<b>Resolution</b>	<b>Resolution</b>	<b>Resolution</b>	<b>Resolution</b>
<b>Color Mode</b>	<b>Color Mode</b>	<b>Color Mode</b>	<b>Color Mode</b>	<b>Color Mode</b>
<b>Duplex</b>	<b>File Format</b>	<b>File Format</b>	<b>File Format</b>	<b>File Format</b>
<b>Darkness</b>	<b>Page Separation</b>	<b>Page Separation</b>	<b>Page Separation</b>	<b>Page Separation</b>
<b>File Name</b>	<b>PDF Encryption<sup>a</sup></b>	<b>PDF Encryption<sup>a</sup></b>	<b>PDF Encryption<sup>a</sup></b>	<b>PDF Encryption<sup>a</sup></b>
	<b>Duplex</b>	<b>Duplex</b>	<b>Digital Signature in PDF<sup>b</sup></b>	<b>Digital Signature in PDF<sup>b</sup></b>
	<b>Darkness</b>	<b>Darkness</b>	<b>Duplex</b>	<b>Duplex</b>
			<b>Darkness</b>	<b>Darkness</b>
			<b>File Name</b>	<b>File Name</b>

a. This option appears only when the **File Format** option is PDF type.

b. This option appears only if you have set a digital signature on the SyncThru™ Web Service (**Settings** tab > **Machine Settings** > **Scan** > **Scan Security** > **Digital Signature in PDF**).

# Menu overview



Scan (see "Scan" on page 225)

FTP	Custom Email	USB	Shared Folder	WSD
<b>Destination</b> (Option settings) <b>Original Size</b> <b>Original Type</b> <b>Resolution</b> <b>Color Mode</b> <b>File Format</b> <b>Page Separation</b> <b>PDF Encryption<sup>a</sup></b> <b>Digital Signature in PDF<sup>b</sup></b> <b>Duplex</b> <b>Darkness</b> <b>File Name</b>	<b>From</b> <b>To</b> <b>CC</b> <b>BCC</b> <b>Subject</b> (Option settings) <b>Original Size</b> <b>Original Type</b> <b>Resolution</b> <b>Color Mode</b> <b>File Format</b> <b>Page Separation</b> <b>PDF Encryption<sup>a</sup></b> <b>Digital Signature in PDF<sup>b</sup></b> <b>Duplex</b> <b>Darkness</b> <b>File Name</b>	(Option settings) <b>Original Size</b> <b>Original Type</b> <b>Resolution</b> <b>Color Mode</b> <b>File Format</b> <b>Page Separation</b> <b>PDF Encryption<sup>a</sup></b> <b>Digital Signature in PDF<sup>b</sup></b> <b>Filing Policy</b> <b>Duplex</b> <b>Darkness</b> <b>File Name</b>	(Option settings) <b>Original Size</b> <b>Original Type</b> <b>Resolution</b> <b>Color Mode</b> <b>File Format</b> <b>Page Separation</b> <b>PDF Encryption<sup>a</sup></b> <b>Digital Signature in PDF<sup>b</sup></b> <b>Filing Policy</b> <b>Duplex</b> <b>Darkness</b> <b>File Name</b>	<b>Destination</b>

a. This option appears only when the **File Format** option is PDF type.

b. This option appears only if you have set a digital signature on the SyncThru™ Web Service (**Settings** tab > **Machine Settings** > **Scan** > **Scan Security** > **Digital Signature in PDF**).



# Menu overview



Fax (see "Fax" on page 221)

Memory Send	On Hook Dial	Delayed Send	Speed Dial Send	Group Dial Send	Redial
<b>To</b>	<b>To</b>	<b>Start Time</b>	<b>To</b>	<b>To</b>	<b>To</b>
(Option settings)	(Option settings)	(Option settings)	(Option settings)	(Option settings)	(Option settings)
<b>Darkness</b>	<b>Darkness</b>	<b>Darkness</b>	<b>Darkness</b>	<b>Darkness</b>	<b>Darkness</b>
<b>Resolution</b>	<b>Resolution</b>	<b>Resolution</b>	<b>Resolution</b>	<b>Resolution</b>	<b>Resolution</b>
<b>Original Type</b>	<b>Color Mode</b>	<b>Original Type</b>	<b>Original Type</b>	<b>Original Type</b>	<b>Original Type</b>
<b>Original Size</b>	<b>Original Type</b>	<b>Original Size</b>	<b>Original Size</b>	<b>Original Size</b>	<b>Original Size</b>
<b>Duplex</b>	<b>Original Size</b>	<b>Duplex</b>	<b>Duplex</b>	<b>Duplex</b>	<b>Duplex</b>
	<b>Duplex</b>				

# Menu overview



Setup (see "System setup" on page 229)

Machine Setup	Address Book	PCL Font	Redial Term	Network Setup
Default Setting	Individual	PS Font	Redial Times	TCP/IP (IPv4)
Copy Default	Group	Address Book	Fax Confirmation	TCP/IP (IPv6)
Scan Default	Print	Fax Setup	Image TCR	Ethernet
Fax Default	Delete All	Send Forward	Auto Reduction	802.1x
Program Management	Reports	Receive Forward	Discard Size	Wi-Fi <sup>d</sup>
Paper Setup	Configuration	Toll Save	Receive Start Code	Wi-Fi On/Off
Tray1	Demo Page	Junk Fax Setup	DRPD Mode <sup>c</sup>	Wi-Fi Settings
Tray2 <sup>a</sup>	Help List	Secure Receive	Paper Source	WPS
Tray 3 <sup>a</sup>	Network Configuration	Prefix Dial	Duplex Print	Connect via PBC
MP Tray	Supplies Information	Stamp Received Name	Fax Setup Wizard	Connect via PIN
Margin	Usage Counter	ECM Mode	Smart Fax	Wi-Fi Direct
Tray Behaviour	Account <sup>b</sup>	Modem Speed	Diagnostics	On/ Off
Auto Tray Switch <sup>a</sup>	Fax Received	Dial Mode <sup>c</sup>	TX/RX Report	Device Name
Paper Substitution	Fax Sent	Ring to Answer		IP Address
Auto Continue	Fax Scheduled Jobs	Receive Mode		Group Owner
Tray Protection <sup>a</sup>	Fax Send Confirmation			Network Key
	Junk Fax			Status
	Email Sent			Wi-Fi Signal
				Clear Wi-Fi Settings

a. This option is available when the optional tray is installed.

b. This option appears only if you have activated your account on the SyncThru™ Web Service (**Security tab > User Access Control > Accounting > Accounting Methods**).

c. This option may not be available depending on your country.

d. For C306xFR, this option is available when the optional wireless/NFC kit is installed.

# Menu overview

## Setup (see "System setup" on page 229)









<b>Protocol Management</b> <b>NFC<sup>a</sup></b> <b>Network Configuration</b> <b>Clear Settings</b>	<b>Print Setup</b> <b>Orientation</b> <b>Duplex</b> <b>Copies</b> <b>Resolution</b> <b>Clear Text</b> <b>Edge Enhancement</b> <b>Trapping</b> <b>Screen</b> <b>Auto CR</b> <b>Skip Blank Pages</b> <b>Emulation</b> <b>Paper Source</b>	<b>Initial Setup</b> <b>Machine ID &amp; Fax Number</b> <b>Date &amp; Time</b> <b>Date Format</b> <b>Clock Mode</b> <b>Select Country</b> <b>Language</b> <b>Default Mode</b> <b>Sound/Volume</b> <b>Key Sound</b> <b>Alarm Sound</b> <b>Fax Sound</b> <b>Power Save</b> <b>Wakeup Event</b> <b>System Timeout</b>	<b>Job Timeout</b> <b>Held Job Timeout</b> <b>Altitude Adjustment</b> <b>Toner Low Alert</b> <b>Firmware Version</b> <b>PDF Type</b> <b>Import Setting</b> <b>Export Setting</b> <b>Default Paper Size</b> <b>CLR Empty Msg<sup>b</sup></b> <b>Image Management</b> <b>Vapor Mode</b>	<b>Stacking Mode</b> <b>Humidity</b> <b>Quiet Mode</b> <b>Logout Confirmation</b> <b>Job Rescheduling</b> <b>Smart Duplex</b> <b>Admin Setup<sup>c</sup></b> <b>User Access Control Authentication</b> <b>Stamp</b> <b>Stamp Activate</b> <b>Item</b> <b>Opacity</b> <b>Position</b> <b>Text Size</b>	<b>Change Admin. Password</b> <b>Firmware Upgrade</b> <b>Image Overwrite</b> <b>Application</b> <b>Secure Print</b> <b>Coverage Counter</b> <b>Troubleshooting</b> <b>Language</b>
---	---	--	--	--	---

a. For C306xFR, this option is available when the optional wireless/NFC kit is installed.

b. This option only appears when small amount of toner is left in the cartridge.

c. You need to enter a password to enter this menu. The default password is **sec00000**.

# Menu overview

 <b>Job Status</b> (see "Eco" on page 244)	 <b>Eco</b> (see "Eco" on page 244)	 <b>Direct USB<sup>a</sup></b> (see "Direct USB" on page 245)		 <b>Document Box</b> (see "Document box" on page 247)	 <b>PrinterOn<sup>b</sup></b> (see "PrinterOn" on page 248)
<b>Current Job</b>  <b>Completed Job</b>	<b>Eco-On or Off</b>  <b>Settings</b>  <b>Default Mode</b> Off On On-Forced <sup>c</sup>  <b>Feature Configuration</b>  Default Custom	<b>Print From</b>   (Option settings)  <b>Copies</b> <b>Auto Fit</b> <b>Duplex</b> <b>Paper Source</b> <b>Color Mode</b>  <b>Scan to USB</b>   (Option settings)  <b>Original Size</b> <b>Original Type</b> <b>Resolution</b> <b>Color Mode</b> <b>File Format</b> <b>PDF Encryption<sup>d</sup></b>	<b>Digital Signature in PDF<sup>e</sup></b>  <b>Filing Policy</b> <b>Duplex</b> <b>Darkness</b> <b>File Name</b>  <b>File Manage</b> <b>Check Space</b>	<b>System Boxes</b>  <b>Stored Print</b> <b>Secured Print</b>  <b>Shared Folder</b>   (Option settings)  <b>Copies</b> <b>Auto Fit</b> <b>Duplex</b> <b>Paper Source</b> <b>Color Mode</b>	

a. You can enter the USB menu when USB memory is inserted into the USB memory port on your machine.

b. This is used only available when **PrinterOn** is enabled. The sub menus that appear in this menu may differ based on whether or not the machine is connected to the **PrinterOn** server.

c. If you set the eco mode on with a password from the SyncThru™ Web Service (**Settings** tab > **Machine Settings** > **System** > **Eco Settings**) or Samsung Easy Printer Manager (**Device Settings** > **Eco**), the **On force** message appears. You have to enter the password to change the eco mode status.

d. This option appears only when the **File Format** option is PDF type.

e. This option appears only if you have set a digital signature on the SyncThru™ Web Service (**Settings** tab > **Machine Settings** > **Scan** > **Scan Security** > **Digital Signature in PDF**).

# Machine's basic settings



You can set the machine's settings from Samsung Easy Printer Manager program or SyncThru™ Web Service.

- If your machine is connected to the local, you can set the machine's setting from **Samsung Easy Printer Manager > Advanced Setting > Device Settings** (see "Using Samsung Easy Printer Manager" on page 309).
- If your machine is connected to the network, you can set the machine's setting from **SyncThru™ Web Service > Settings tab > Machine Settings** (see "SyncThru™ Web Service" on page 296).

After installation is complete, you may want to set the machine's default settings.

To change the machine's default settings, follow these steps:



It may be necessary to press **OK** to navigate to lower-level menus for some models.

- 1 Select  (**Menu**) > **System Setup** > **Machine Setup** on the control panel.  
OR

For the model with a touch screen, press  (**Setup**) > **Machine Setup** > **Next** > **Initial Setup** on the touch screen.

- 2 Select the option you want.
  - **Language:** change the language that is displayed on the control panel.

- **Date & Time:** When you set the time and date, they are used in delay fax and delay print. They are printed on reports. If, however, they are not correct, you need to change it to the correct time.
- **Clock Mode:** You can set your machine to display the current time using either a 12-hour or 24-hour format.
- **Power Save:** When you are not using the machine for a while, use this feature to save power.



When you press the  (**Power/Wakeup**) button on the control panel, start printing, or a fax is received, the product will wake up from the power saving mode.

- **Altitude Adjustment:** Print quality is affected by atmospheric pressure, which atmospheric pressure is determined by the height of the machine above sea level. Before you set the altitude value, determine the altitude where you are (see "Altitude adjustment" on page 250).

3

Select the sub option you want, then press **OK** to save the selection.

For the model with a touch screen, press  (Back) to save the selection.

4

Press the  (**Stop/Clear** or **Stop**) button or  (Home) icon to return to ready mode.



Refer to below links to set other settings useful for using the machine.

- See "Entering various characters" on page 253.
- See "Setting the paper size and type" on page 52.
- See "Setting up the fax address book" on page 255.

# Media and tray

This chapter provides information on how to load print media into your machine.

## Selecting print media

You can print on a variety of print media, such as plain paper, envelopes, and labels. Always use print media that meet the guidelines for use with your machine.

## Guidelines for select the print media

Print media that does not meet the guidelines outlined in this user's guide may cause the following problems:

- Poor print quality
- Increased paper jams
- Premature wear on the machine.

Properties, such as weight, composition, grain, and moisture content, are important factors that affect the machine's performance and the output quality.

When you choose print materials, consider the following:

- The type, size, and weight of the print media for your machine are described in print media specifications (see "Print media specifications" on page 132).
- Desired outcome: The print media you choose should be appropriate for your project.
- Brightness: Some print media are whiter than others and produce sharper, more vibrant images.
- Surface smoothness: The smoothness of the print media affects how crisp the printing looks on the paper.



- Some print media may meet all of the guidelines in this user's guide and still not produce satisfactory results. This may be the result of the sheets characteristics, improper handling, unacceptable temperature and humidity levels, or other variables over which cannot be controlled.
- Before purchasing large quantities of print media, ensure that it meets the requirements specified in this user's guide.



- Using print media that does not meet these specifications may cause problems or require repairs. Such repairs are not covered by Samsung's warranty or service agreements.
- The amount of paper put into the tray may differ according to media type used (see "Print media specifications" on page 132).
- Make sure not to use the inkjet photo paper with this machine. It could cause damage to the machine.
- Using flammable print media can cause a fire.
- Use designated print media (see "Print media specifications" on page 132).



The use of flammable media or foreign materials left in the printer may lead to overheating of the unit and, in rare cases may cause a fire.

The amount of paper put into the tray may differ according to media type used (see "Print media specifications" on page 132).

# Media and tray

## Tray overview

To change the size, you need to adjust the paper guides.

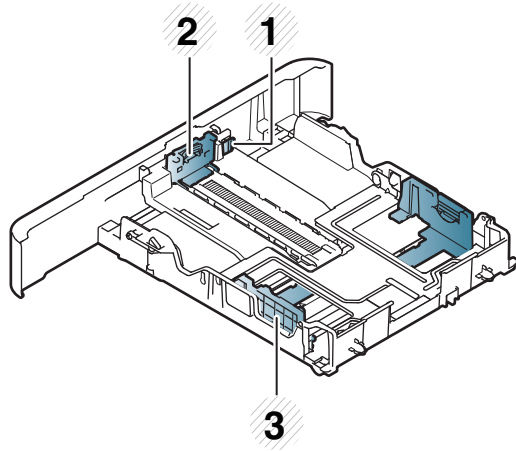

- 1 Tray extend lever
- 2 Paper length guide
- 3 Paper width guide



### For Legal-sized paper

Push button as shown and pull out the tray.

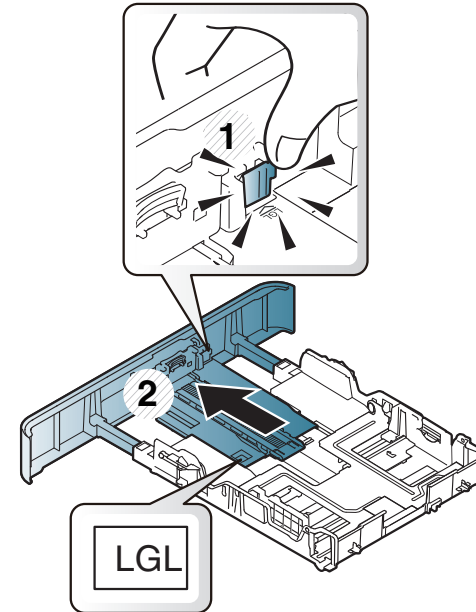

If you do not adjust the guide, it may cause paper registration, image skew, or jamming of the paper.

# Media and tray

## Loading paper in the tray



Illustrations on this user's guide may differ from your machine depending on its options or models. Check your machine type (see "Front view" on page 18).

## Tray 1 / optional tray



The procedure is same for all optional trays.

- 1 Pull out the paper tray.

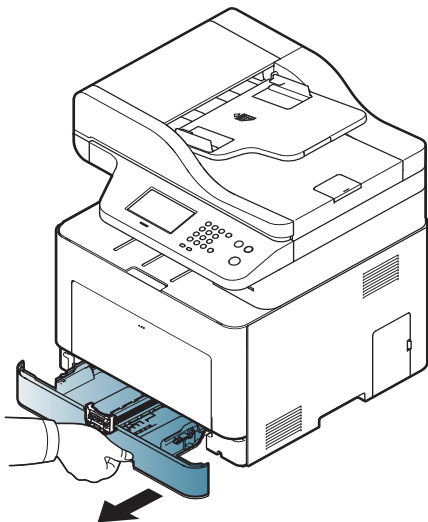

- 2 Squeeze the paper width guide and paper length lever to locate them in the correct paper size slot marked at the bottom of the tray to adjust to the size (see "Tray overview" on page 43).

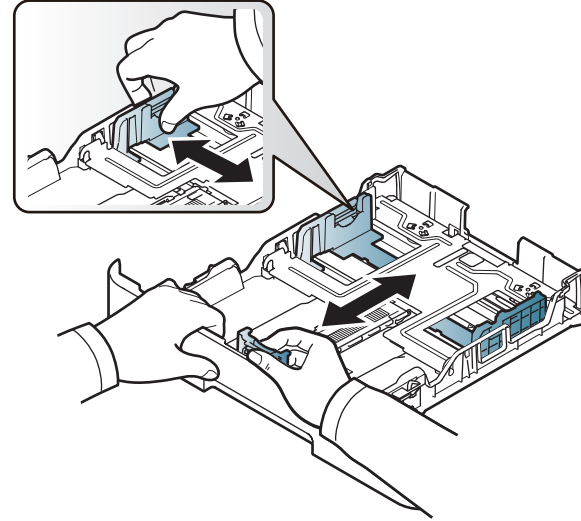

- 3 Flex or fan the edge of the paper stack to separate the pages before loading papers.

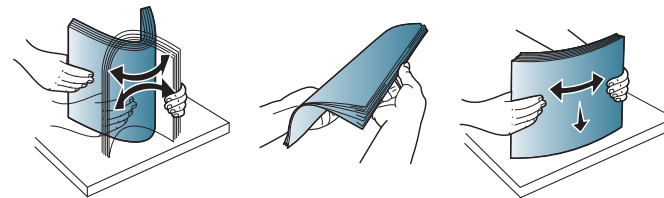



# Media and tray

- 4 After inserting paper into the tray, squeeze the paper width guides and paper length guide.

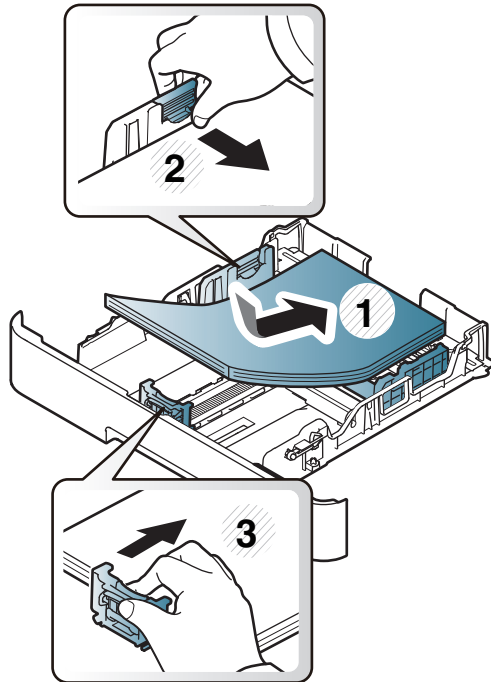

- Do not push the paper width guide too far causing the media to warp.
- If you do not adjust the paper width guide, it may cause paper jams.

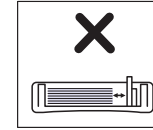
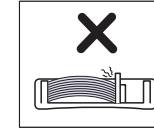
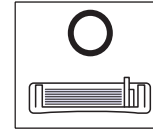

- Do not use a paper with a leading-edge curl, it may cause a paper jam or the paper can be wrinkled.

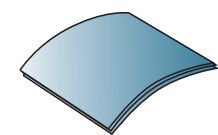
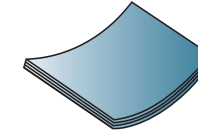
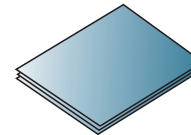

# Media and tray

- 5 Insert the tray back into the machine.

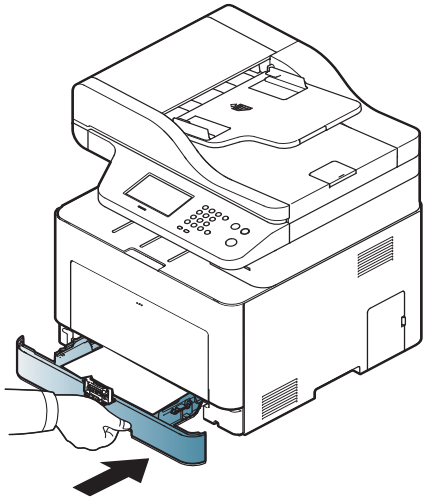

- 6 When you print a document, set the paper type and size for tray (see "Setting the paper size and type" on page 52).

## Multi-purpose tray

The multi-purpose tray can hold special sizes and types of print material, such as postcards, note cards, and envelopes (see "Print media specifications" on page 132).

### Tips on using the multi-purpose tray

- Load only one type, size and weight of print media at a time in the multi-purpose tray.
- To prevent paper jams, do not add paper while printing when there is still paper in the multi-purpose tray. This also applies to other types of print media.
- Always load the specified print media only to avoid paper jams and print quality problems (see "Print media specifications" on page 132).
- Flatten any curl on postcards, envelopes, and labels before loading them into the multi-purpose tray.

# Media and tray

- 1 Press the push-release of multi-purpose tray and it down to open.

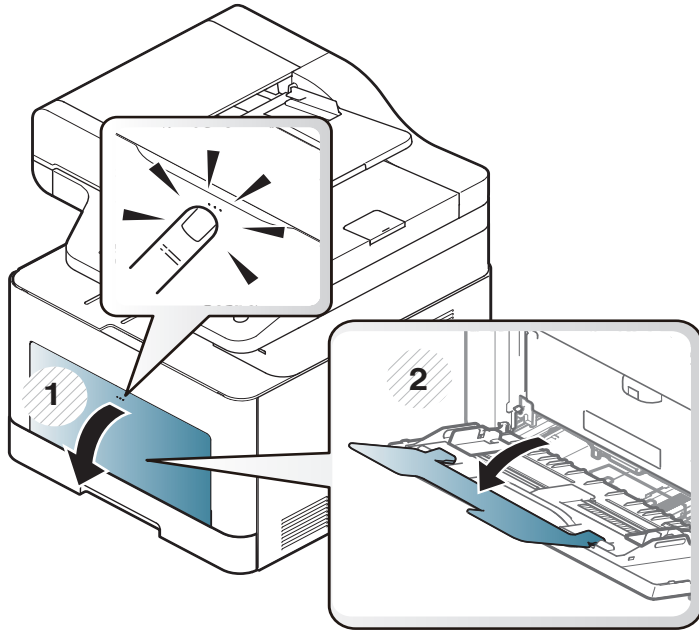

- 2 Load the paper.

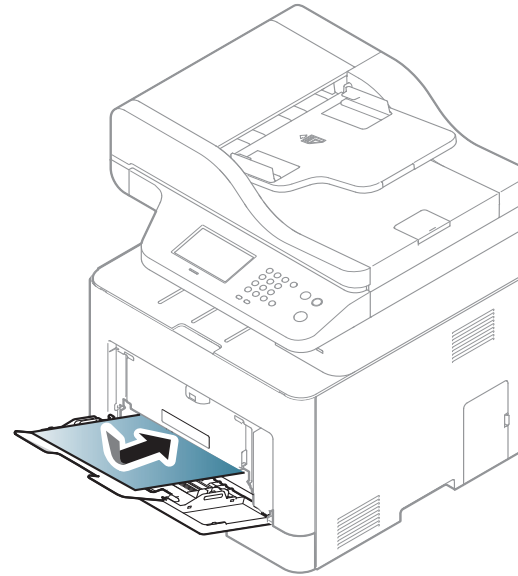

# Media and tray

- 3 Squeeze the multi-purpose tray paper width guides and adjust them to the width of the paper. Do not force them too much, or the paper will bent resulting in a paper jam or skew.

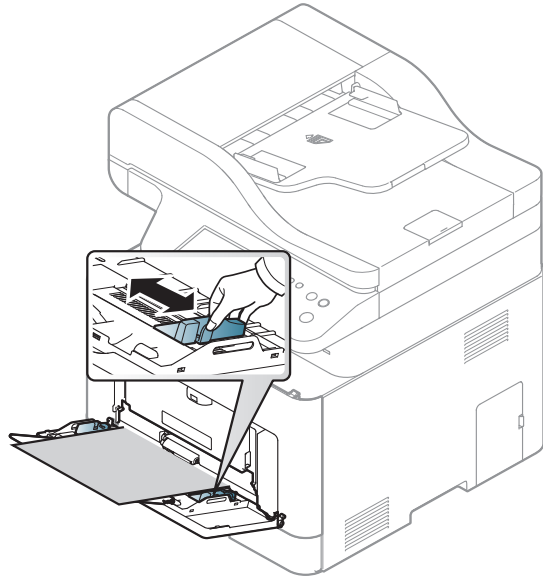

- When printing the special media, you must follow the loading guideline (see "Printing on special media" on page 48).
- When papers overlap when printing using multi-purpose tray, open tray 1 and remove overlapping papers then try printing again.



- 4 When you print a document, set the paper type and size for the multi-purpose tray.

For information about setting the paper type and size on the control panel (see "Setting the paper size and type" on page 52).

## Printing on special media

The table below shows the special media usable in each tray.

The paper setting in the machine and driver should match to print without a paper mismatch error.

- You change the paper setting set in the machine from Samsung Easy Printer Manager program or SyncThru™ Web Service.
  - If your machine is connected to the local, you can set the machine's setting from **Samsung Easy Printer Manager > Advanced Setting > Device Settings** (see "Using Samsung Easy Printer Manager" on page 309).
  - If your machine is connected to the network, you can set the machine's setting from **SyncThru™ Web Service > Settings tab > Machine Settings** (see "SyncThru™ Web Service" on page 296).
- You change the paper setting set in the machine using control panel.
  - Select  (Menu) > **System Setup > Paper Setup > Paper Size or Paper Type** on the control panel.
  - OR
  - Select  (Setup) > **Machine Setup > Next > Paper Setup > select a tray > Paper Size or Paper Type** on the touch screen.
- You change the paper setting set in the machine using printer driver.
  - Set the paper type from the **Printing preferences** window > **Paper** tab > **Paper Type** (see "Opening printing preferences" on page 59).

# Media and tray



- When using special media, we recommend you feed one sheet at a time (see "Print media specifications" on page 132).
- Illustrations on this user's guide may differ from your machine depending on its options or models. Check your machine type (see "Front view" on page 18).

To see paper weights for each sheet, refer to "Print media specifications" on page 132.

Types	Tray 1	Optional tray	Multi-purpose tray
Plain	•	•	•
Thick	•	•	•
Thicker	•		•
Thin	•	•	•
Bond	•	•	•
Color	•		•
CardStock	•	•	•
Labels	•		•
Envelope	•		•
Preprinted	•		•
Cotton	•		•
Recycled	•	•	•
Archive	•	•	•
Letterhead	•	•	•
Punched	•	•	•
Glossy Photo	•		•

(•: Supported, Blank: Not supported)

## Envelope

Printing successfully on envelopes depends upon the quality of the envelopes.

To print an envelope, place it as shown in the following figure.

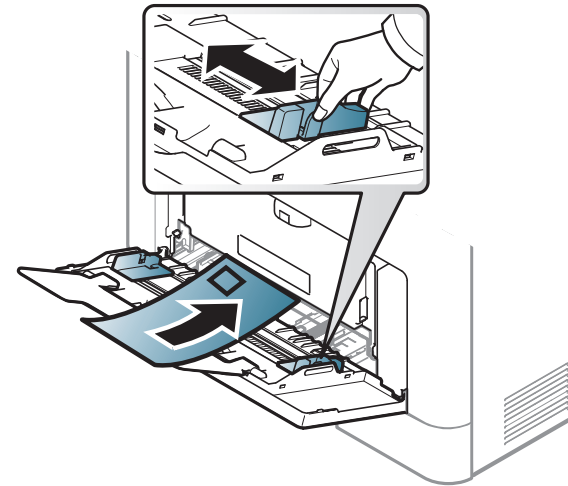

- When selecting envelopes, consider the following factors:
  - **Weight:** should not exceed 90 g/m<sup>2</sup> otherwise; jams may occur.
  - **Construction:** should lie flat with less than 6 mm curl and should not contain air.
  - **Condition:** should not be wrinkled, nicked, nor damaged.
  - **Temperature:** should resist the heat and pressure of the machine during operation.
- Use only well-constructed envelopes with sharp and well-creased folds.
- Do not use stamped envelopes.

# Media and tray

- Do not use envelopes with clasps, snaps, windows, coated lining, self-adhesive seals, or other synthetic materials.
- Do not use damaged or poorly made envelopes.
- Be sure the seam at both ends of the envelope extends all the way to the corner of the envelope.

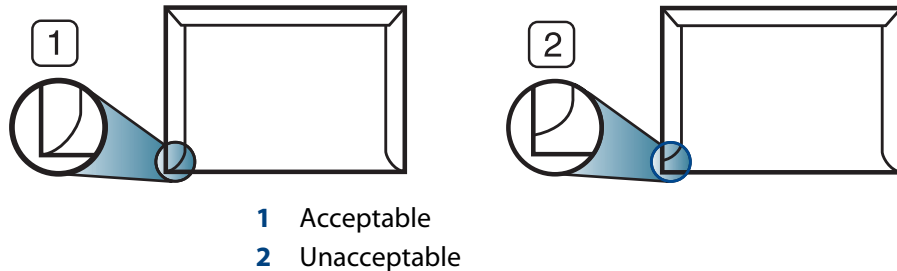

- Envelopes with a peel-off adhesive strip or with more than one flap that folds over to seal must use adhesives compatible with the machine's fusing temperature for 0.1 second about 170 °C (338 °F). The extra flaps and strips might cause wrinkling, creasing, or jams, and may even damage the fuser.
- For the best print quality, position margins no closer than 15 mm from the edges of the envelope.
- Avoid printing over the area where the envelope's seams meet.

## Labels

To avoid damaging the machine, use only labels designed for use in laser printers.

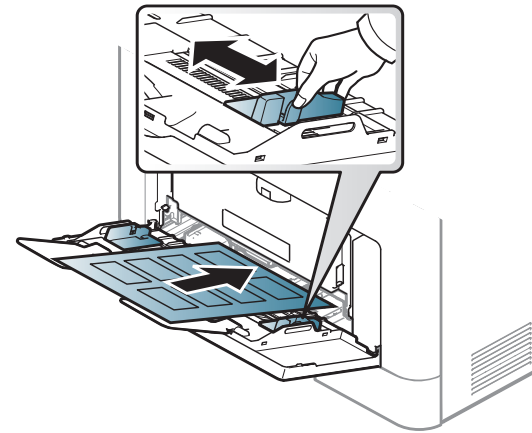

- When selecting labels, consider the following factors:
  - **Adhesives:** Should be stable at your machine's fusing temperature about 170 °C (338 °F).
  - **Arrangement:** Only use labels with no exposed backing between them. Labels can peel off sheets that have spaces between the labels, causing serious jams.
  - **Curl:** Must lie flat with no more than 13 mm of curl in any direction.
  - **Condition:** Do not use labels with wrinkles, bubbles, or other indications of separation.
- Make sure that there is no exposed adhesive material between labels. Exposed areas can cause labels to peel off during printing, which can cause paper jams. Exposed adhesive can also cause damage to machine components.
- Do not run a sheet of labels through the machine more than once. The adhesive backing is designed for only a single pass through the machine.
- Do not use labels that are separating from the backing sheet or are wrinkled, bubbled, or otherwise damaged.

# Media and tray

## Card stock/ Custom-sized paper

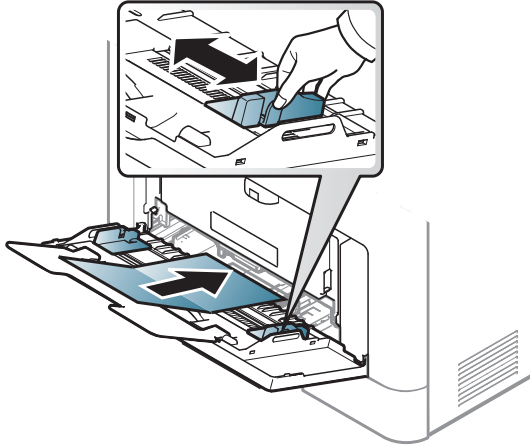

- In the software application, set the margins to at least 6.4 mm (0.25 inches) away from the edges of the material.

## Preprinted paper

When loading preprinted paper, the printed side should be facing up with an uncurled edge at the front. If you experience problems with paper feeding, turn the paper around. Note that print quality is not guaranteed.

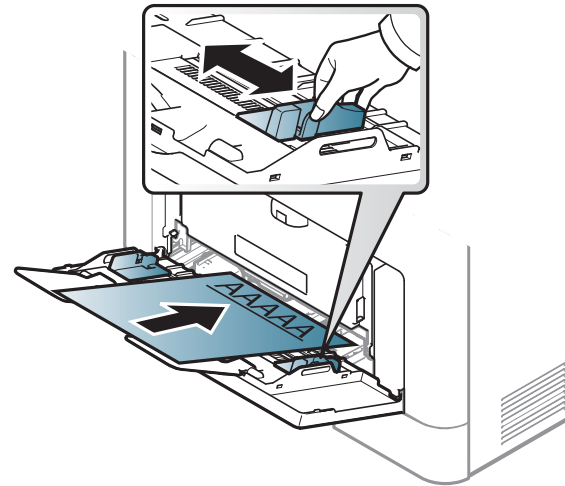



- Must be printed with heat-resistant ink that will not melt, vaporize, or release hazardous emissions when subjected to the machine's fusing temperature for 0.1 second about 170 °C (338 °F).
- Preprinted paper ink must be non-flammable and should not adversely affect machine rollers.
- Before you load preprinted paper, verify that the ink on the paper is dry. During the fusing process, wet ink can come off preprinted paper, reducing print quality.

# Media and tray

## Setting the paper size and type

After loading paper in the paper tray, set the paper size and type.

The paper setting in the machine and driver should match to print without a paper mismatch error.

- You change the paper setting set in the machine from Samsung Easy Printer Manager program or SyncThru™ Web Service.
  - If your machine is connected to the local, you can set the machine's setting from **Samsung Easy Printer Manager > Advanced Setting > Device Settings** (see "Using Samsung Easy Printer Manager" on page 309).
  - If your machine is connected to the network, you can set the machine's setting from **SyncThru™ Web Service > Settings tab > Machine Settings** (see "SyncThru™ Web Service" on page 296).
- You change the paper setting set in the machine using control panel.
  - Select  (**Menu**) > **System Setup > Paper Setup > Paper Size** or **Paper Type** on the control panel.  
OR  
Press  (**Setup**) > **Machine Setup > Next > Paper Setup** > select a tray > **Paper Size** or **Paper Type** on the touch screen.
- You change the paper setting set in the machine using printer driver.
  - Set the paper type from the **Printing preferences** window > **Paper** tab > **Paper Type** (see "Opening printing preferences" on page 59).



If you want to use special-sized paper such as billing paper, select the **Paper** tab > **Size > Edit...** and set **Custom Paper Size Settings** in the **Printing Preferences** (see "Opening printing preferences" on page 59).



# Media and tray

## Using the output support



The surface of the output tray may become hot if you print a large number of pages at once. Make sure that you do not touch the surface, and do not allow children near it.

The printed pages stack on the output support, and the output support will help the printed pages to align. Unfold the output support.

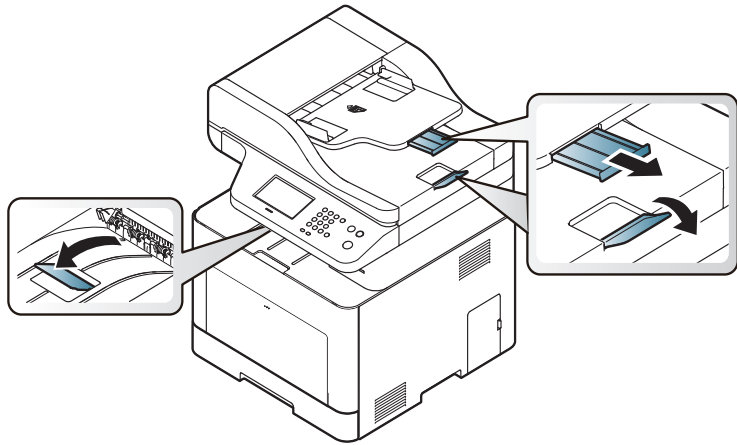

Illustrations on this user's guide may differ from your machine depending on its options or models. Check your machine type (see "Front view" on page 18).

## Preparing originals

- Do not load paper smaller or larger than custom size.
  - **Scan glass:** X : 216 mm ( 8.50 inches), Y: 297 mm (11.69 inches)
  - **Document feeder (ADF or RADF):** X: 148 - 216 mm ( 5.83 x 8.50 inches), Y: 210 - 356 mm (8.27 x 14.02 inches)
- Do not attempt to load the following s of paper, in order to prevent paper jam, low print quality and machine damage.
  - Carbon-paper or carbon-backed paper
  - Coated paper
  - Onion skin or thin paper
  - Wrinkled or creased paper
  - Curled or rolled paper
  - Torn paper
- Remove all staples and paper clips before loading.
- Make sure any glue, ink, or correction fluid on the paper is completely dry before loading.
- Do not load originals that include different sizes or weights of paper.
- Do not load booklets, pamphlets, or documents with other unusual characteristics.

# Media and tray

## Loading originals

You can use the scanner glass or the document feeder (ADF or RADF) to load an original for copying, scanning, and sending a fax.



Illustrations on this user's guide may differ from your machine depending on its options or models. Check your machine type (see "Front view" on page 18).

## On the scanner glass

Using the scanner glass, you can copy or scan originals. You can get the best scan quality, especially for colored or gray-scaled images. Make sure that no originals are in the document feeder. If an original is detected in the document feeder, the machine gives it priority over the original on the scanner glass.

- 1 Lift and open the scanner lid.

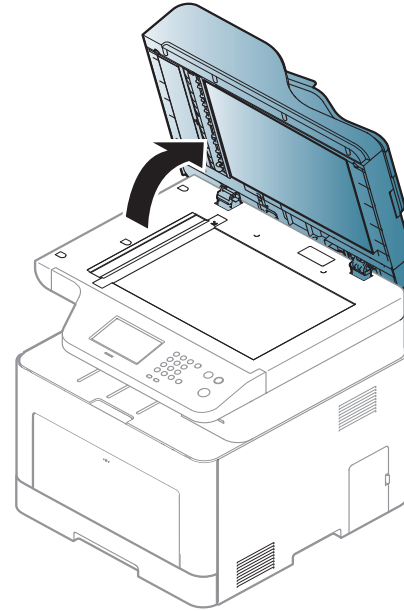

# Media and tray

- 2 Place the original face down on the scanner glass. Align it with the registration guide at the top left corner of the glass.

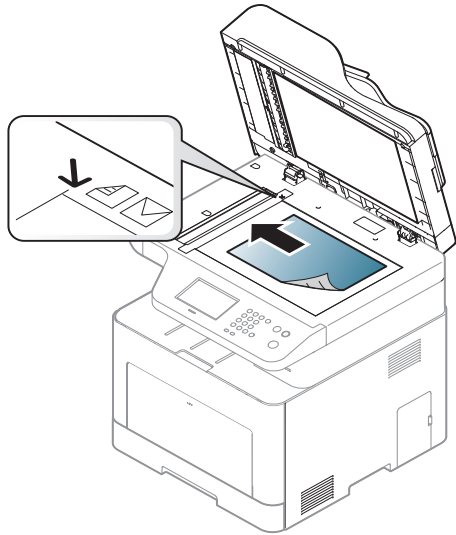

- 3 Close the scanner lid.



- Leaving the scanner lid open while copying may affect copy quality and toner consumption.
- Dust on the scanner glass may cause black spots on the printout. Always keep it clean (see "Cleaning the machine" on page 98).
- If you are copying a page from a book or magazine, lift the scanner lid until its hinges are caught by the stopper and then close the lid. If the book or magazine is thicker than 30 mm, start copying with the scanner lid open.



- Be careful not to break the scanner glass. You may get hurt.
- Do not put hands while closing the scanner lid. The scanner lid may fall on your hands and get hurt.
- Do not look into the light from inside of the scanner while copying or scanning. It is harmful to eyes.

## In the document feeder (ADF or RADF)

Using the document feeder (ADF or RADF), you can load up to 50 sheets of paper (80 g/m<sup>2</sup>, 21 lbs bond) for one job.

- 1 Flex or fan the edge of the paper stack to separate the pages before loading originals.

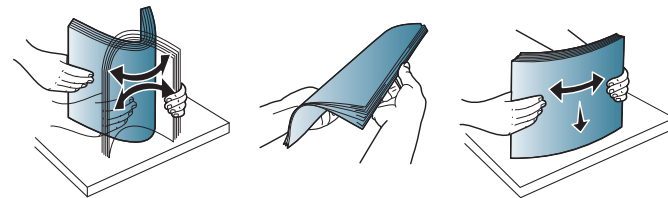

# Media and tray

- 2 Load the original face up into the document feeder input tray. Make sure that the bottom of the original stack matches the paper size marked on the document input tray.

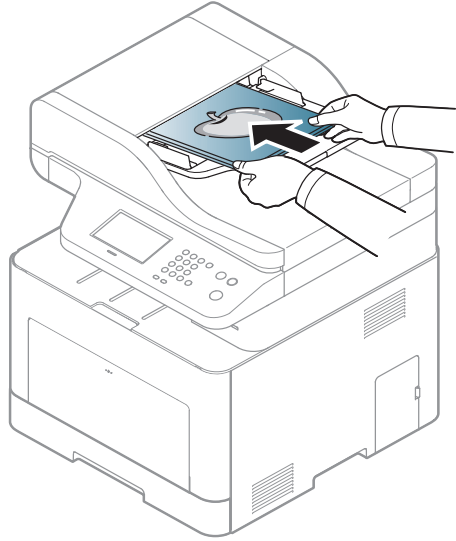

- 3 Adjust the document feeder width guides to the paper size.

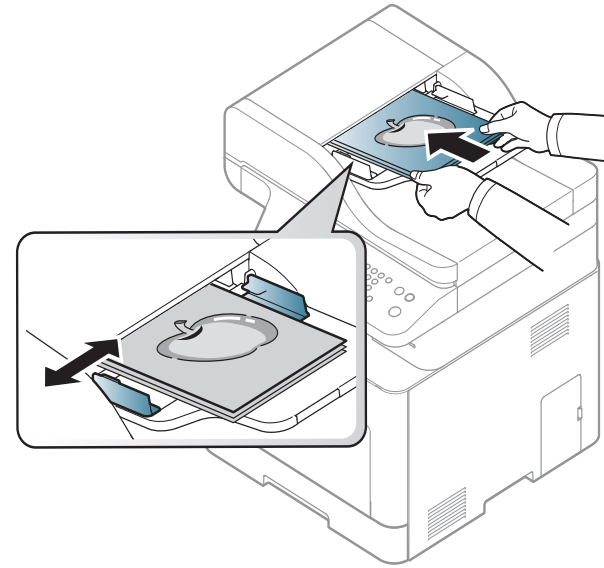

Dust on the document feeder glass may cause black lines on the printout. Always keep the glass clean (see "Cleaning the machine" on page 98).

# Basic printing



For special printing features, refer to the Advanced Guide (see "Using advanced print features" on page 261).

## Printing



If you are a Mac, Linux or UNIX operating systems user, refer to the Advanced Guide.

- See "Mac printing" on page 272.
- See "Linux printing" on page 274.
- See "Unix printing" on page 275.

The following **Printing Preferences** window is for Notepad in Windows 7.

- 1 Open the document you want to print.
- 2 Select **Print** from the **File** menu.

- 3 Select your machine from the **Select Printer** list.

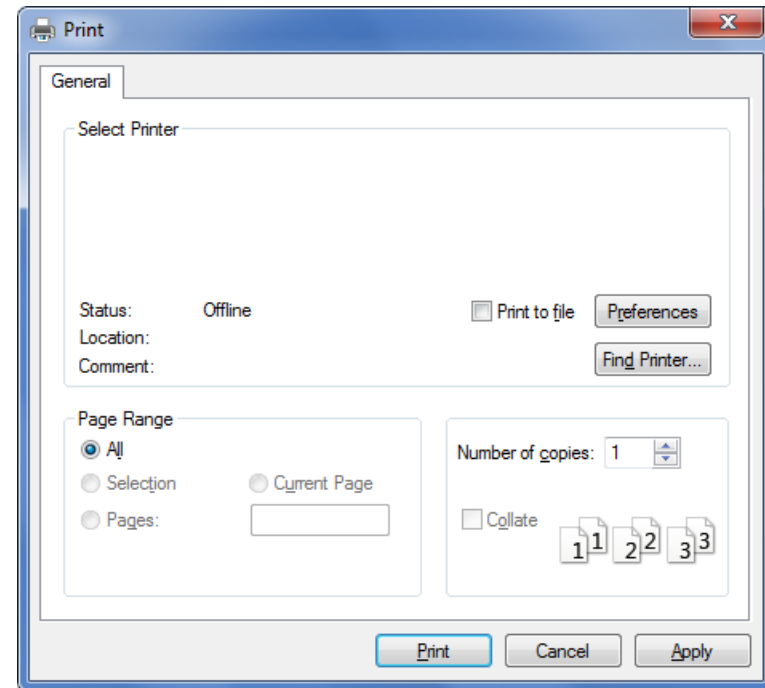

- 4 The basic print settings including the number of copies and print range are selected within the **Print** window.





To take advantage of the advanced printing features, click **Properties** or **Preferences** from the **Print** window (see "Opening printing preferences" on page 59).

- 5 To start the print job, click **OK** or **Print** in the **Print** window.

# Basic printing

## Canceling a print job





If the print job is waiting in the print queue or print spooler, cancel the job as follows:

- You can access this window by simply double-clicking the machine icon (  ) in the Windows task bar.
- You can also cancel the current job by pressing the  (**Stop/Clear** or **Stop**) button on the control panel.

# Basic printing

## Opening printing preferences



- The **Printing Preferences** window that appears in this user's guide may differ depending on the machine in use.
- When you select an option in **Printing Preferences**, you may see a warning mark  or . An  mark means you can select that certain option but it is not recommended, and an  mark means you cannot select that option due to the machine's setting or environment.

- 1 Open the document you want to print.
- 2 Select **Print** from the file menu. The **Print** window appears.
- 3 Select your machine from the **Select Printer**.
- 4 Click **Properties** or **Preferences**.



The screenshot may differ depending on model.

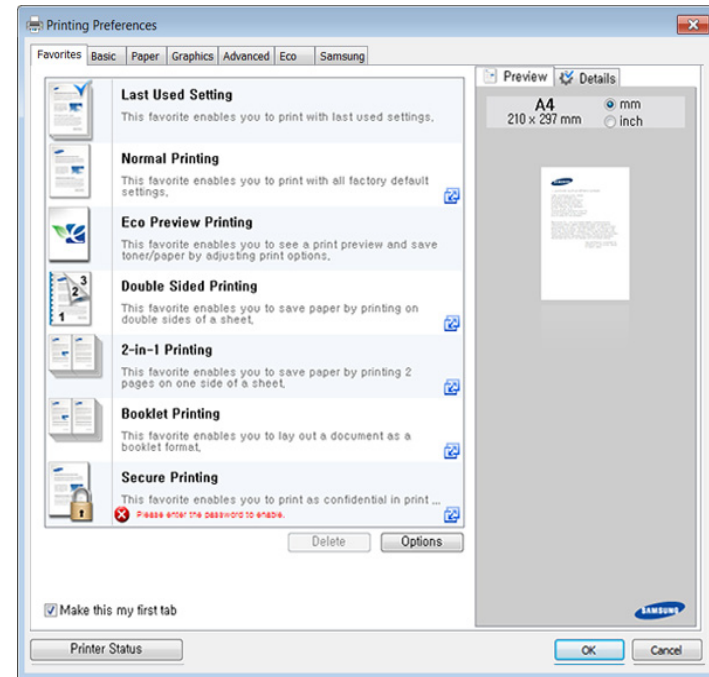

- You can apply **Eco** features to save paper and toner before printing (see "Easy Eco Driver" on page 304).
- You can check the machine's current status pressing the **Printer Status** button (see "Using Samsung Printer Status" on page 312).
- The printer driver includes a user interface that is optimized for touchscreens. To use this UI, click **Samsung Printer Center > Device Options** and then select **Stylish User Interface** (see "Using Samsung Printer Center" on page 306).

# Basic printing

## Using a favorite setting

The **Favorites** option, which is visible on each preferences tab except for the **Favorites** and **Samsung** tab, allows you to save the current preferences for future use.

To save a **Favorites** item, follow these steps:

- 1 Change the settings as needed on each tab.
- 2 Enter a name for the item in the **Favorites** input box.

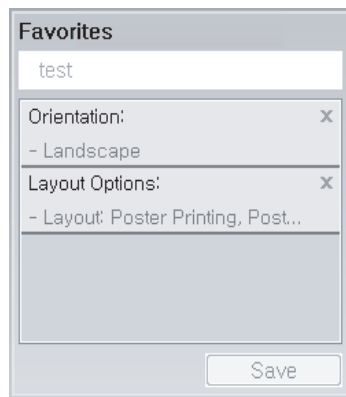

- 3 Click **Save**.
- 4 Enter name and description, and then select the desired icon.
- 5 Click **OK**. When you save **Favorites**, all current driver settings are saved.



To use a saved setting, select it in the **Favorites** tab. The machine is now set to print according to the settings you have selected.

To delete saved settings, select it in the **Favorites** tab and click **Delete**.

## Using help

Click the option you want to know on the **Printing Preferences** window and press **F1** on your keyboard.



# Basic printing

## Eco printing

The **Eco** function cuts toner consumption and paper usage. The **Eco** function allows you to save print resources and lead you to eco-friendly printing.

If you press the **Eco** button from the control panel, eco mode is enabled. The default setting of Eco mode is duplex, Multiple Pages per Side (2-up), Skip Blank Pages.

## Setting Eco mode on the control panel



- Accessing menus may differ from model to model (see "Accessing the menu" on page 28 or "Control panel overview" on page 21).
- It may be necessary to press **OK** to navigate to lower-level menus for some models.

**1** Select  (**Menu**) > **System Setup** > **Machine Setup** > **Eco Settings** on the control panel.

OR

Press **Eco** on the control panel.

OR

For the model with a touch screen, press  (**Eco**) > **Settings** > **Next** on the touch screen.

**2** Select the option you want.

- **Default Mode:** Select this to turn on or off the eco mode. If you set the eco mode on with a password from the SyncThru™ Web Service (**Settings** tab > **Machine Settings** > **System** > **Eco Settings**) or Samsung Easy Printer Manager (**Device Settings** > **Eco**), the **On force** message appears. You have to enter the password to change the eco mode status.
- **Select Template** (or **Feature Configuration**)
  - **Default Eco** (or **Default**): The machine is set to default eco mode.
  - **Custom Eco** (or **Custom**): Change any necessary values.



Before you select this item, you must set the eco function in SyncThru™ Web Service (**Settings** tab > **Machine Settings** > **System** > **Eco Settings**) or Samsung Easy Printer Manager (**Device Settings** > **Eco**).

**3** Press **OK** to save the selection.

For the model with a touch screen, press  (Back) to save the selection.

# Basic printing

## Setting eco mode on the driver



To take advantage of the advanced printing features, click **Properties** or **Preferences** from the **Print** window (see "Opening printing preferences" on page 59).

Open the **Eco** tab to set eco mode. When you see the eco image () , that means the eco mode is currently enabled.

## Eco options

- **Printer Default:** Follows the settings from the machine's control panel.
- **None:** Disables eco mode.
- **Eco Printing:** Enables eco mode. Activate the various eco items you want to use.
- **Password:** If the administrator fixed to enable the eco mode, you have to enter the password to change the status.



**Password** button: You can set from SyncThru™ Web Service (**Settings** tab > **Machine Settings** > **System** > **Eco Settings**) or Samsung Easy Printer Manager (**Device Settings** > **Eco**), the password button is activated. To change the print settings, click on this button, enter the password or need to contact the administrator.

## Result simulator

**Result Simulator** shows the estimated results of reduced emission of carbon dioxide, used electricity, and the amount of saved paper in accordance with the settings you selected.

- The results are calculated on the basis that the total number of printed paper is one hundred without a blank page when the Eco mode is disabled.
- Refers to the calculation coefficient about CO<sub>2</sub>, energy, and paper from **IEA**, the index of Ministry of Internal Affairs and Communication of Japan and [www.remanufacturing.org.uk](http://www.remanufacturing.org.uk). Each model has a different index.
- The power consumption in printing mode refers to the average printing power consumption of this machine.
- The actual saved or reduced amount may differ depending on the operating system used, computing performance, application software, connection method, media type, media size, job complexity, etc.

# Basic printing

## Secure printing



- Some menus may not appear on the display depending on options or models. If so, it is not applicable to your machine.
- You might not be able to print a complex document using the RAM Disk.

When you use a printing device in an office, school or other public place, you can protect your personal documents or confidential information by using the secure printing feature.

## Starting secure printing from the SyncThru™ Web Service



For C306xFR and C306xFW, an SD (Secure Digital) card is installed by default so Secure Printing is available without a RAM disk.

- 1 Access a web browser, such as Internet Explorer, from Windows.  
Enter the machine IP address of your printer (<http://xxx.xxx.xxx.xxx>) in the address field and press the Enter key or click **Go**.
- 2 Click Login on the upper right of SyncThru™ Web Service website (see "Logging into SyncThru™ Web Service" on page 297).
- 3 **Settings > Machine Settings > System > RAM Disk.**
- 4 Enable **RAM Disk**.

## Printing secure documents from the control panel

- 1 Select (Menu) > **Job Management** > **Secured Job** on the control panel.

OR

For the model with a touch screen, select (Document Box) > **System Boxes** > **Next** > **Secured Print** on the touch screen.





- 2 Enter the ID and password that you set from the printer driver.
- 3 Select the document to print.
- 4 Print the document.

# Basic copying



- For special printing features, refer to the Advanced Guide (see "Copy" on page 215).
- Accessing menus may differ from model to model (see "Accessing the menu" on page 28 or "Control panel overview" on page 21).

## Basic copy

- 1 Place a single document face down on the document glass, or load the documents face up into the document feeder (see "Loading originals" on page 54).
- 2 Select  **(Menu)** > **Copy Feature** on the control panel.  
OR  
For the model with a touch screen, select  **(Copy)** > **Basic Copy** on the touch screen.
- 3 If you want to customize the copy settings including reduce/enlarge, darkness, original type, and more by using the control panel (see "Changing the settings for each copy" on page 64).  
For the model with a touch screen, press  (Option settings) > select the option you want >  (Back).
- 4 Enter the number of copies using the arrow or number keypad, if necessary.
- 5 Press  **(Start)**.



- If you need to cancel the copying job during the operation, press the  **(Stop/Clear or Stop)** button and the copying will stop.

## Changing the settings for each copy

Your machine provides default settings for copying so that you can quickly and easily make a copy.



- If you press the  **(Stop/Clear or Stop)** button twice while setting the copy options, all of the options you have set for the current copy job will be canceled and returned to their default status. Or, they will automatically return to their default status after the machine completes the copy in progress.
- Accessing menus may differ from model to model (see "Accessing the menu" on page 28).
- It may be necessary to press **OK** to navigate to lower-level menus for some models.

# Basic copying

## Darkness

If you have an original containing faint marking and dark images, you can adjust the brightness to make a copy that is easier to read.

- 1 Select  (Menu) > **Copy Feature** > **Darkness** on the control panel.

OR

Select **Darkness** on the control panel.

For the model with a touch screen, press  (**Copy**) > **Basic Copy** >

 (Option settings) > **Darkness** on the touch screen.

- 2 Select the option you want.

For example, the **Light+5** being the lightest, and the **Dark+5** being the darkest.

- 3 Press **OK** to save the selection.

For the model with a touch screen, press  (Back) to save the selection.

- 4 Press the  (**Stop/Clear** or **Stop**) button or  (Home) icon to return to ready mode.

## Original Type

The original setting is used to improve the copy quality by selecting the document for the current copy job.

- 1 Select  (Menu) > **Copy Feature** > **Original Type** on the control panel.

OR

For the model with a touch screen, press  (**Copy**) > **Basic Copy** >

 (Option settings) > **Original Type** on the touch screen.

- 2 Select the option you want.

- **Text:** Use for originals containing mostly text.
- **Text/Photo:** Use for originals with mixed text and photographs.



If texts in the printout is blurry, select **Text** to get the clear texts.

- **Photo:** Use when the originals are photographs.
- **Magazine:** Use when the originals are magazines.

- 3 Press **OK** to save the selection.

For the model with a touch screen, press  (Back) to save the selection.

- 4 Press the  (**Stop/Clear** or **Stop**) button or  (Home) icon to return to ready mode.

# Basic copying

## Reduced or enlarged copy



You can reduce or enlarge the size of a copied image from 25% to 400% from the document feeder or scanner glass.





- This feature may not be available depending on model or optional goods (see "Variety feature" on page 8).
- If the machine set to Eco mode, reduce and enlarge features are not available.

## To select from the predefined copy sizes

- 1 Select  (**Menu**) > **Copy Feature** > **Reduce/Enlarge** on the control panel.  
OR



For the model with a touch screen, press  (**Copy**) > **Custom Copy** >  (Option settings) > **Reduce/Enlarge** on the touch screen.



- 2 Select the option you want.  
For the model with a touch screen, select the option you want using arrows.
- 3 Press **OK** to save the selection.  
For the model with a touch screen, press  (Back) to save the selection.
- 4 Press the  (**Stop/Clear** or **Stop**) button or  (Home) icon to return to ready mode.

## To scale the copy by directly entering the scale rate

- 1 Select  (**Menu**) > **Copy Feature** > **Reduce/Enlarge** > **Custom** on the control panel.

OR

For the model with a touch screen, press  (**Copy**) > **Custom Copy** >  (Option settings) > **Reduce/Enlarge** > **Custom** on the touch screen.

- 2 Enter the copy size you want using the numeric keypad.
- 3 Press **OK** to save the selection.  
For the model with a touch screen, press  (Back) to save the selection.
- 4 Press the  (**Stop/Clear** or **Stop**) button or  (Home) icon to return to ready mode.



When you make a reduced copy, black lines may appear at the bottom of your copy.

# Basic copying

## ID card copying

Your machine can print 2-sided originals on one sheet.

The machine prints one side of the original on the upper half of the paper and the other side on the lower half without reducing the size of the original. This feature is helpful for copying a small-sized item such as business card.



- The original must be placed on the scanner glass to use this feature.
- If the machine set to Eco mode, this feature is not available.

Depending on the model, the operating procedure may differ.

- 1 Select  (Menu) > **Copy Feature** > **Layout** > **ID Copy** on the control panel. Press  (Start).

OR

For the model with a touch screen, press  (Copy) > **ID Copy** on the touch screen.

- 2 **Place Front Side and Press**  appears on the display.

For the model with a touch screen, follow the instructions on the touch screen.

- 3 Place the front side of an original facing down on the scanner glass where arrows indicate as shown. Then, close the scanner lid.

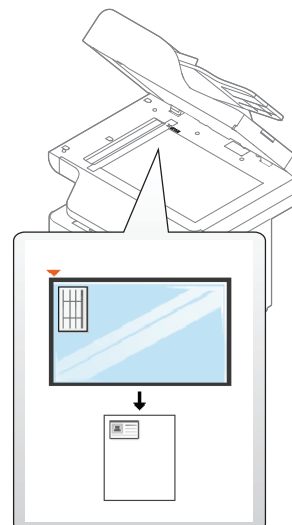

- 4 Press  (Start).

Your machine begins scanning the front side.

- 5 **Place Rear Side and Press**  appears on the display.

For the model with a touch screen, follow the instructions on the touch screen

# Basic copying

- 6 Turn the original over and place it on the scanner glass where arrows indicate as shown. Then, close the scanner lid.

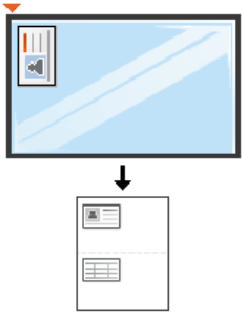

- 7 Press the  (**Start**) button.

Your machine begins scanning the back side.



- If you do not press the  (**Start**) button, only the front side will be copied.
- If the original is larger than the printable area, some portions may not be printed.



# Basic scanning



For special scanning features, refer to the Advanced Guide (see "Scan features" on page 277).

## Basic Scanning

This is the normal and usual procedure for scanning originals.

This is a basic scanning method for USB-connected machine.



- Accessing menus may differ from model to model.
- It may be necessary to press **OK** to navigate to lower-level menus for some models.
- If you want to scan using the network, refer to the Advanced Guide (see "Scanning from network connected machine" on page 278).

**1** Place a single document face down on the document glass, or load the documents face up into the document feeder (see "Loading originals" on page 54).

**2** Select **Scan to** > **Scan to PC** on the control panel.  
OR

For the model with a touch screen, press  (**Scan**) > **Local PC** on the touch screen.



If you see **Not Available** message, check the port connection, or select **Enable Scan from Device Panel** in **Samsung Easy Printer Manager** > **Advanced Setting** > **Scan to PC Settings**.

**3** Select the scan destination you want and press **OK**.

For the model with a touch screen, press **Next** > select the scan destination you want on the touch screen.



- You can create and save the frequently used settings as a profile list. Also you can add and delete the profile and save each profile to a different path.
- To change the **Samsung Easy Printer Manager** > **Advanced Setting** > **Scan to PC Settings**.

**4** Select the option you want and press **OK**.

For the model with a touch screen, press  (Option settings) > select the option you want using arrows > **Start** button on the touch screen

**5** Scanning begins.



Scanned image is saved in computer's **Documents\Scan** folder. The saved folder may differ, depending on your operating system or the application you are using.

# Basic faxing



- This function is not supported for C306xND (see "Variety feature" on page 8).
- For special faxing features, see "Fax features" on page 286.
- Accessing menus may differ from model to model (see "Accessing the menu" on page 28 or "Control panel overview" on page 21).



- You cannot use this machine as a fax via the internet phone. For more information ask your internet service provider.
- We recommend using traditional analog phone services (PSTN: Public Switched Telephone Network) when connecting telephone lines to use a fax machine. If you use other Internet services (DSL, ISDN, VoIP), you can improve the connection quality by using the Micro-filter. The Micro-filter eliminates unnecessary noise signals and improves connection quality or Internet quality. Since the DSL Micro-filter is not provided with the machine, contact your Internet service provider for use on DSL Micro-filter.

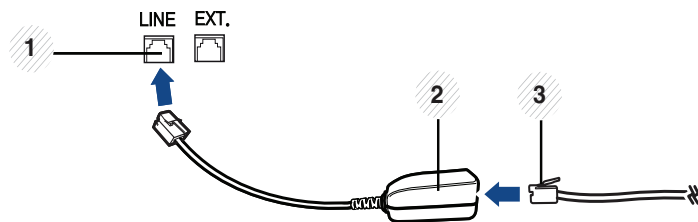

- 1 Line port
- 2 Micro filter
- 3 DSL modem / Telephone line (see "Rear view" on page 20).



## Preparing to fax

Before you send or receive a fax, you need to connect the supplied line cord to your telephone wall jack (see "Rear view" on page 20). Refer to the Quick Installation Guide how to make a connection. The method of making a telephone connection is different from one country to another.

## Sending a fax



When you place the originals, you can use either the document feeder or the scanner glass. If the originals are placed on both the document feeder and the scanner glass, the machine will read the originals on the document feeder first, which has higher priority in scanning.

- 1 Place a single document face down on the document glass, or load the documents face up into the document feeder (see "Loading originals" on page 54).
- 2 Press  (**Fax**) > **Memory Send** on the touch screen.
- 3 Adjust the resolution and the darkness to suit your fax needs. Press  (Option settings) > select the option you want using arrows >  (Back) > **Next** on the touch screen.

# Basic faxing

- 4 Press **Direct Input** or **Fax List** > enter the destination fax number using number keypad on the touch screen (see "Understanding keypad" on page 253).
- 5 Press **Send** on the touch screen.  
The machine starts to scan and send the fax to the destinations.





- If you want to send a fax directly from your computer, use Samsung Network PC Fax (see "Sending a fax from the computer" on page 287).
- When you want to cancel a fax job, press the  (**Stop/Clear** or **Stop**) button before the machine starts transmission.
- If you used the scanner glass, the machine shows the message asking to place another page.

## Sending a fax manually



Perform the following to send a fax using  (**On Hook Dial**) on the control panel.

- 1 Place a single document face down on the document glass, or load the documents face up into the document feeder (see "Loading originals" on page 54).
- 2 Press  (**Fax**) > **On Hook Dial** on the touch screen.

- 3 Adjust the resolution and the darkness to suit your fax needs. Press  (Option settings) > select the option you want using arrows >  (Back) > **Next** on the touch screen.
- 4 Press **On Hook** on the touch screen.
- 5 Enter a fax number using the number keypad on the touch screen.
- 6 Press  (**Start**) on the control panel when you hear a high-pitched fax signal from the remote fax machine.

## Sending a fax to multiple destinations

You can use the multiple send feature, which allows you to send a fax to multiple locations. Originals are automatically stored in memory and sent to a remote station. After transmission, the originals are automatically erased from memory.

- 1 Place a single document face down on the document glass, or load the documents face up into the document feeder (see "Loading originals" on page 54).
- 2 Press  (**Fax**) > **SpeedDial Send** or **Group Dial Send** on the touch screen.
- 3 Adjust the resolution and the darkness to suit your fax needs. Press  (Option settings) > select the option you want using arrows >  (Back) > **Next** on the touch screen.

# Basic faxing

- 4 Select the option you want speed dial numbers or select a group dial number.
- 5 Press **Send** on the touch screen.  
The machine begins sending the fax to the numbers you entered in the order in which you entered them.  
Multi send report is printed after sending faxes.

## Receiving a fax

Your machine is preset Fax mode at the factory. When you receive a fax, the machine answers the call on a specified number of rings and automatically receives the fax.

## Adjusting the document settings

Before starting a fax, change the following settings according to your original's status to get the best quality.





- Accessing menus may differ from model to model (see "Accessing the menu" on page 28 or "Control panel overview" on page 21).
- It may be necessary to press **OK** to navigate to lower-level menus for some models.

## Resolution

The default document settings produce good results when using typical text-based originals. However, if you send originals that are of poor quality, or contain photographs, you can adjust the resolution to produce a higher quality fax.



The resolution setting is applied to the current fax job. To change the default setting (see Advanced Guide).

- 1 Press  (**Fax**) > select a fax such as **Memory Send, On Hook Dial, Delayed Send**, or etc. >  (Option settings) > **Resolution** on the touch screen.
- 2 Select the option you want.
  - **Standard:** Originals with normal sized characters.
  - **Fine:** Originals containing small characters or thin lines or originals printed using a dot-matrix printer.
  - **Super Fine:** Originals containing extremely fine detail. **Super Fine** mode is enabled only if the machine with which you are communicating also supports the Super Fine resolution.

When your machine is set to **Super Fine** resolution and the fax machine with which you are communicating does not support **Super Fine** resolution, the machine transmits using the highest resolution mode supported by the other fax machine.

- 3 Press the  (Home) icon to return to ready mode.

# Basic faxing



## Darkness

---

You can select the degree of darkness of the original document.



The darkness setting is applied to the current fax job. To change the default setting (see "Fax" on page 221).

- 1 Press  (**Fax**) > select a fax such as **Memory Send**, **On Hook Dial**, **Delayed Send**, or etc. >  (Option settings) > **Darkness** on the touch screen.
- 2 Select a darkness level you want.
- 3 Press the  (Home) icon to return to ready mode.

# Using USB memory device

This chapter explains how to use a USB memory device with your machine.

## About USB memory

USB memory devices are available with a variety of memory capacities to give you more room for storing documents, presentations, downloaded music and videos, high resolution photographs or whatever other files you want to store or move.

You can do the following tasks on your machine by using a USB memory device.

- Scan documents and save them on a USB memory device
- Print data stored on a USB memory device
- Restore backup files to the machine's memory
- Format the USB memory device
- Check the available memory space

## Plugging in a USB memory device

The USB memory port on the front of your machine is designed for USB V1.1 and USB V2.0 memory devices. Your machine supports USB memory devices with FAT16/FAT32 and a sector size of 512 bytes.

Check your USB memory device's file system from your dealer.

You must use only an authorized USB memory device with an A plug connector.

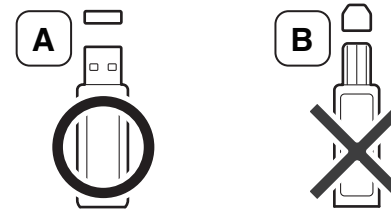

Use only a metal-shielded USB memory device.

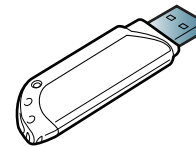

Only use a USB memory device that has obtained compatibility certification; otherwise, the machine might not recognize it.

Insert a USB memory device into the USB memory port on your machine.

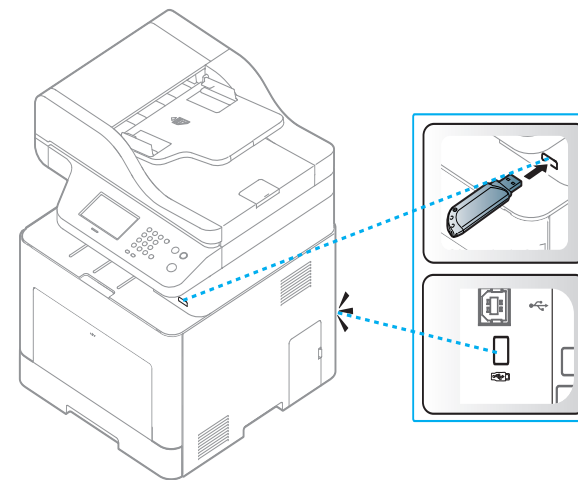

# Using USB memory device



- Do not remove the USB memory device while the machine is in operation or writing to or reading from USB memory. The machine warranty does not cover damage caused by user's misuse.
- If your USB memory device has certain features such as security settings and password settings, your machine may not automatically detect it. For details about these features, see the user's guide of the USB memory device.



## Printing from a USB memory device

You can directly print files stored on a USB memory device.

File is supported by Direct Print option.

- **PRN:** Only files created by provided driver with your machine are compatible. PRN files can be created by selecting the **Print to file** check box when you print a document. The document will be saved as a PRN file, rather than printed on paper. Only PRN files created in this fashion can be printed directly from USB memory device.
- **TIFF:** TIFF 6.0 Baseline
- **JPEG:** JPEG Baseline
- **PDF:** PDF 1.7 and below
- **XPS:** XML Paper Specification 1.0

## To print a document from a USB memory device

- 1 Insert a USB memory device into the USB memory port on your machine, and then press **Direct USB > USB Print** on the control panel.  
OR  
For the model with a touch screen, press  (**USB**) > **Print From > Next** on the touch screen.
- 2 Select the folder or file you want and press **OK**.  
If you see [+] or [D] in the front of a folder name, there are one or more files or folders in the selected folder.  
For the model with a touch screen, select the folder or file you want.
- 3 Select the number of copies to be printed or enter the number.
- 4 Press **OK, Start** or **Print** to start printing the selected file.  
After printing the file, the display asks if you want to print another job.  
For the model with a touch screen, press **Print** on the touch screen. Go to step 6.
- 5 Press **OK** when **Yes** appears to print another job, and repeat from step 2. Otherwise, press the left/right arrow to select **No** and press **OK**.
- 6 Press the  (**Stop/Clear** or **Stop**) button or  (Home) icon to return to ready mode.

# Using USB memory device

## Scanning to a USB memory device



You can scan a document and save the scanned image onto a USB memory device.

## Scanning

- 1 Insert a USB memory device into the USB memory port on your machine.
- 2 Place a single document face down on the document glass, or load the documents face up into the document feeder (see "Loading originals" on page 54).
- 3 Select **Scan to** > **Scan to USB** on the control panel.  
OR  
For the model with a touch screen, press  (**Scan**) > **USB** > **Next** > **Scan to USB** > **Start** on the touch screen.  
The machine begins scanning.
- 4 After scanning is complete, you can remove the USB memory device from the machine.

## Customizing Scan to USB

You can specify image size, file format, or color mode for each scanning to USB job.

- 1 Insert a USB memory device into the USB memory port on your machine.
- 2 Select  (**Menu**) > **Scan Feature** > **USB Feature** on the control panel.  
OR  
For the model with a touch screen, press  (**USB**) > **Scan to USB** >  (Option settings) on the touch screen.
- 3 Select the setting option you want appears.  
For the model with a touch screen, select the option you want using arrows.



Some features may not be available depending on model.

- **Original Size:** Sets the image size.
- **Original Type:** Sets the original document's.
- **Resolution:** Sets the image resolution.
- **Color Mode:** Sets the color mode. If you select **Mono** in this option, you cannot select JPEG in **File Format**.
- **File Format:** Sets the file format in which the image is to be saved. When you select **TIFF** or **PDF**, you can select to scan multiple pages. If you select **JPEG** in this option, you cannot select **Mono** in **Color Mode**.



# Using USB memory device

- **Duplex:** Sets the duplex mode.
- **Darkness:** Sets the brightness level to scan an original.
- **File Name:** Sets the file name.
- **File Policy:** Sets the policy to save files between overwriting or renaming.
- **PDF Encryption:** Sets the encrypts **PDF** files.

**4** Select the desired status you want and press **OK**.

For the model with a touch screen, press  (Back) to save the selection. Go to step 5.

**5** Repeat steps 2 and 3 to set other setting options.

**6** Press the  (**Stop/Clear** or **Stop**) button or  (Home) icon to return to ready mode.

## Backing up data

Data in the machine's memory can be accidentally erased due to power failure or storage failure. Backup helps you protect the system settings by storing them as backup files on a USB memory device.

## Backing up data

**1** Insert the USB memory device into the USB memory port on your machine.

**2** Select  (**Menu**) > **System Setup** > **Machine Setup** > **Export Setting** on the control panel.

OR

For the model with a touch screen, press  (**Setup**) > **Machine Setup** > **Next** > **Initial Setup** > **Export Setting** on the touch screen.

**3** Select **Setup Data** or **Address Book**.





**4** Select the file you want to back up.

**5** Press **OK** or **Yes** when the confirmation window appears.

**6** Press the  (**Stop/Clear** or **Stop**) button or  (Home) icon to return to ready mode.

# Using USB memory device

## Restoring data

- 1 Insert the USB memory device on which the backup data is stored in to the USB memory port.
- 2 Select  (Menu) > **System Setup** > **Machine Setup** > **Import Setting** on the control panel.  
OR  
For the model with a touch screen, press  (**Setup**) > **Machine Setup** > **Next** > **Initial Setup** > **Import Setting** on the touch screen.
- 3 Select **Setup Data** or **Address Book**.
- 4 Select the file you want to restore.
- 5 Press **OK** or **Yes** when the confirmation window appears.
- 6 Press the  (**Stop/Clear** or **Stop**) button or  (Home) icon to return to ready mode.

## Managing USB memory

You can delete image files stored on a USB memory device one by one or all at once by reformatting the device.







If you see [+] or [D] in the front of a folder name, there are one or more files or folders in the selected folder.







After deleting files or reformatting a USB memory device, files cannot be restored. Therefore, confirm that you no longer need the data before deleting it.

## Deleting an image file

- 1 Insert a USB memory device into the USB memory port on your machine.
- 2 Select **Direct USB** > **File Manage** > **Delete**.  
OR  
For touch screen model, press  (**USB**) > **File Manage** > **Next** > select a file >  (Option settings) > **Delete** on the touch screen.
- 3 Press **OK** or **Yes** when the confirmation window appears.
- 4 Press the  (**Stop/Clear** or **Stop**) button or  (Home) icon to return to ready mode.



# Using USB memory device

## Formatting a USB memory device

- 1 Insert a USB memory device into the USB memory port on your machine.
- 2 Select **Direct USB > File Manage > Format**.  
OR  
For touch screen model, press  (**USB**) > **File Manage** > **Next** > select a file >  (Option settings) > **Format** on the touch screen.
- 3 Press **OK** or **Yes** when the confirmation window appears.
- 4 Press the  (**Stop/Clear** or **Stop**) button or  (Home) icon to return to ready mode.

## Viewing the USB memory status

You can check the amount of memory space available for scanning and saving documents.

- 1 Insert a USB memory device into the USB memory port on your machine.
- 2 Select **Direct USB > File Manage > Check Space**.  
OR  
For touch screen model, press  (**USB**) > **Check Space** > **Next** on the touch screen.
- 3 The available memory space appears on the display.
- 4 Press the  (**Stop/Clear** or **Stop**) button or  (Home) icon to return to ready mode.



# 3. Maintenance

This chapter provides information about purchasing supplies, accessories and maintenance parts available for your machine.

• <b>Ordering supplies and accessories</b>	<b>81</b>
• <b>Available supplies</b>	<b>82</b>
• <b>Available accessories</b>	<b>83</b>
• <b>Available maintenance parts</b>	<b>84</b>
• <b>Storing the toner cartridge</b>	<b>85</b>
• <b>Redistributing toner</b>	<b>87</b>
• <b>Replacing the toner cartridge</b>	<b>89</b>
• <b>Replacing the waste toner container</b>	<b>92</b>
• <b>Installing accessories</b>	<b>94</b>
• <b>Monitoring the supplies life</b>	<b>96</b>
• <b>Setting the toner low alert</b>	<b>97</b>
• <b>Cleaning the machine</b>	<b>98</b>
• <b>Tips for moving &amp; storing your machine</b>	<b>104</b>

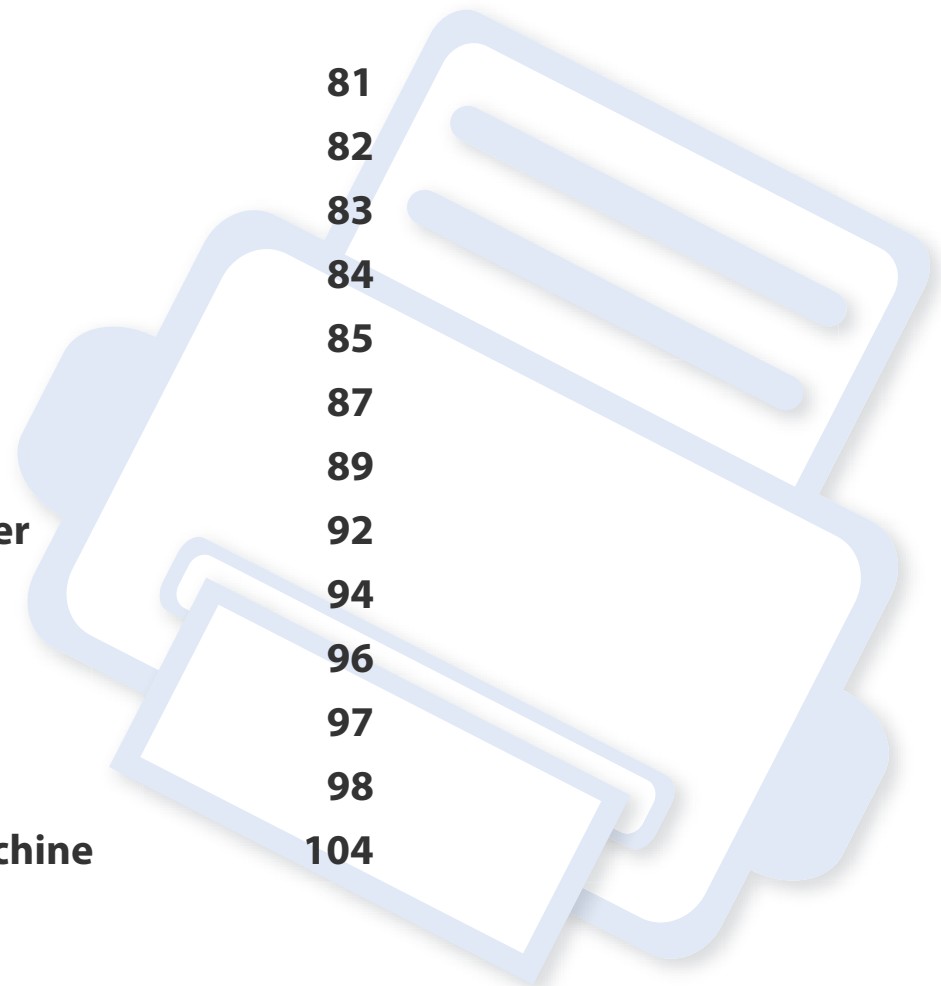

# Ordering supplies and accessories



Available accessories may differ from country to country. Contact your sales representatives to obtain the list of available supplies, and maintenance parts.

To order Samsung-authorized supplies, accessories, and maintenance parts, contact your local Samsung dealer or the retailer where you purchased your machine. You can also visit [www.samsung.com/supplies](http://www.samsung.com/supplies), and then select your country/region to obtain the contact information for service.

# Available supplies

When supplies reach the end of their life spans, you can order the followings of supplies for your machine:

Type	Average yield <sup>a</sup>	Part name
<b>Standard yield toner cartridge<sup>b</sup></b>	<ul style="list-style-type: none"><li>• Average continuous black cartridge yield: Approx. 2,500 standard pages (Black)</li><li>• Average continuous color cartridge yield: Approx. 2,500 standard pages (Yellow/Magenta/Cyan)</li></ul>	<ul style="list-style-type: none"><li>• <b>CLT-K503S</b>: Black</li><li>• <b>CLT-Y503S</b>: Yellow</li><li>• <b>CLT-M503S</b>: Magenta</li><li>• <b>CLT-C503S</b>: Cyan</li></ul>
<b>High yield toner cartridge</b>	<ul style="list-style-type: none"><li>• Average continuous black cartridge yield: Approx. 8,000 standard pages (Black)</li><li>• Average continuous color cartridge yield: Approx. 5,000 standard pages (Yellow/Magenta/Cyan)</li></ul>	<ul style="list-style-type: none"><li>• <b>CLT-K503L</b>: Black</li><li>• <b>CLT-Y503L</b>: Yellow</li><li>• <b>CLT-M503L</b>: Magenta</li><li>• <b>CLT-C503L</b>: Cyan</li></ul>
<b>Waste toner container</b>	Approx. 20,000 black pages or 5,000 color pages	<b>CLT-W506</b>

a. Declared yield value in accordance with ISO/IEC 19798. The number of pages may be affected by operating environment, printing interval, graphics, media type and media size.

b. The standard yield toner cartridge is available only for C306xFW.



Depending on the options, percentage of image area and job mode used, the toner cartridge's lifespan may differ.



When purchasing new toner cartridges or other supplies, these must be purchased in the same country as the machine you are using. Otherwise, new toner cartridges or other supplies will be incompatible with your machine due to different configurations of toner cartridges and other supplies according to the specific country conditions.



Samsung does not recommend using non-genuine Samsung toner cartridge such as refilled or remanufactured toner. Samsung cannot guarantee non-genuine Samsung toner cartridge's quality. Service or repair required as a result of using non-genuine Samsung toner cartridges will not be covered under the machine's warranty.

# Available accessories

You can purchase and install accessories to enhance your machine's performance and capacity.



- Some features and optional goods may not be available depending on model or country (see "Features by model" on page 7).
- Be sure to read safety information and regulatory information before using the supplies and accessories. (see Safety information and Regulatory information)

Accessory	Function	Part name
<b>Optional trays (Tray2, Tray3)</b>	If you are experiencing frequent paper supply problems, you can attach an additional 550 <sup>a</sup> sheet trays.	<b>SL-SCF3000</b>
<b>Wireless/NFC kit<sup>b</sup></b>	This kit lets you use your machine as a Wireless and NFC machine.	<b>SL-NWE001X</b>

a. Plain paper 75 g/m<sup>2</sup> (20 lbs bond).

b. C306xND and C306xFR only.

# Available maintenance parts

You need to replace the maintenance parts at specific intervals to keep the machine in the best condition and avoid print quality and paper feeding problems resulting from the worn-out parts. Maintenance parts are mostly rollers, belts and pads. However, the replacement period and parts may differ depending on the model. Replacing maintenance parts can be performed only by an authorized service provider, dealer, or the retailer where you bought the machine. To purchase maintenance parts, contact the retailer where you bought the machine. The replacement period for the maintenance parts is informed by the "Samsung Printer Status" program. Or on the UI (User Interface) if your machine supports a display screen.



# Storing the toner cartridge

Toner cartridges contain components that are sensitive to light, temperature and humidity. Samsung suggests users follow these recommendations to ensure optimal performance, highest quality, and longest life from your new Samsung toner cartridge.

Store the cartridge in the same environment in which the printer will be used. This should be in controlled temperature and humidity conditions. The toner cartridge should remain in its original and unopened package until installation – if original packaging is not available, cover the top opening of the cartridge with paper and store in a dark cabinet.

Opening the cartridge package prior to use dramatically shortens its useful shelf and operating life. Do not store on the floor. If the toner cartridge is removed from the printer, follow the instructions below to store the toner cartridge properly.

- Store the cartridge inside the protective bag from the original package.
- Store lying flat (not standing on end) with the same side facing up as if it were installed in the machine.
- Do not store supplies in any of the following conditions:
  - Temperature greater than 40°C (104°F).
  - Humidity range less than 20% or greater than 80%.
  - An environment with extreme changes in humidity or temperature.
  - Direct sunlight or room light.
  - Dusty places.
  - A car for a long period of time.
  - An environment where corrosive gases are present.
  - An environment with salty air.

## Handling instructions

- Do not touch the surface of the photoconductive drum in the cartridge.
- Do not expose the cartridge to unnecessary vibrations or shock.
- Never manually rotate the drum, especially in the reverse direction; this can cause internal damage and toner spillage.

## Toner cartridge usage

Samsung does not recommend or approve the use of non-Samsung brand toner cartridges in your printer including generic, store brand, refilled, or remanufactured toner cartridges.



Samsung printer warranty does not cover damage to the machine caused by the use of refilled, remanufactured, or non-Samsung brand toner cartridges.

# Storing the toner cartridge

## Estimated cartridge life

Estimated cartridge life (the toner cartridge yield) depends on the amount of toner that print jobs require. The actual print yield may vary depending on the print density of the pages you print on, operating environment, percentage of image area, printing interval, media type and/or media size. For example, if you print a lot of graphics, the consumption of the toner is higher and you may need to change the cartridge more often.

# Redistributing toner

When the toner cartridge is near the end of its life:

- White streaks or light printing occurs and/or density varies from side to side.
- The **Status** LED blinks orange. The toner-related message saying that the toner is low may appear on the display.
- The computer's Samsung Printing Status program window appears on the computer telling you which color cartridge is low on toner (see "Using Samsung Printer Status" on page 312).

If this happens, you can temporarily improve print quality by redistributing the remaining toner in the cartridge. In some cases, white streaks or light printing will still occur even after you have redistributed the toner.



Illustrations on this user's guide may differ from your machine depending on its options or models. Check your machine type (see "Front view" on page 18).



- To prevent damage to the toner cartridge, do not expose it to light for more than a few minutes. Cover it with a piece of paper, if necessary.
- Do not touch the green area of the toner cartridge. Use the handle on the cartridge to avoid touching this area.
- Do not use sharp objects such as a knife or scissors to open the toner cartridge package. They might scratch the drum of the cartridge.
- If toner gets on your clothing, wipe it off with a dry cloth and wash clothing in cold water. Hot water sets toner into fabric.

# Redistributing toner

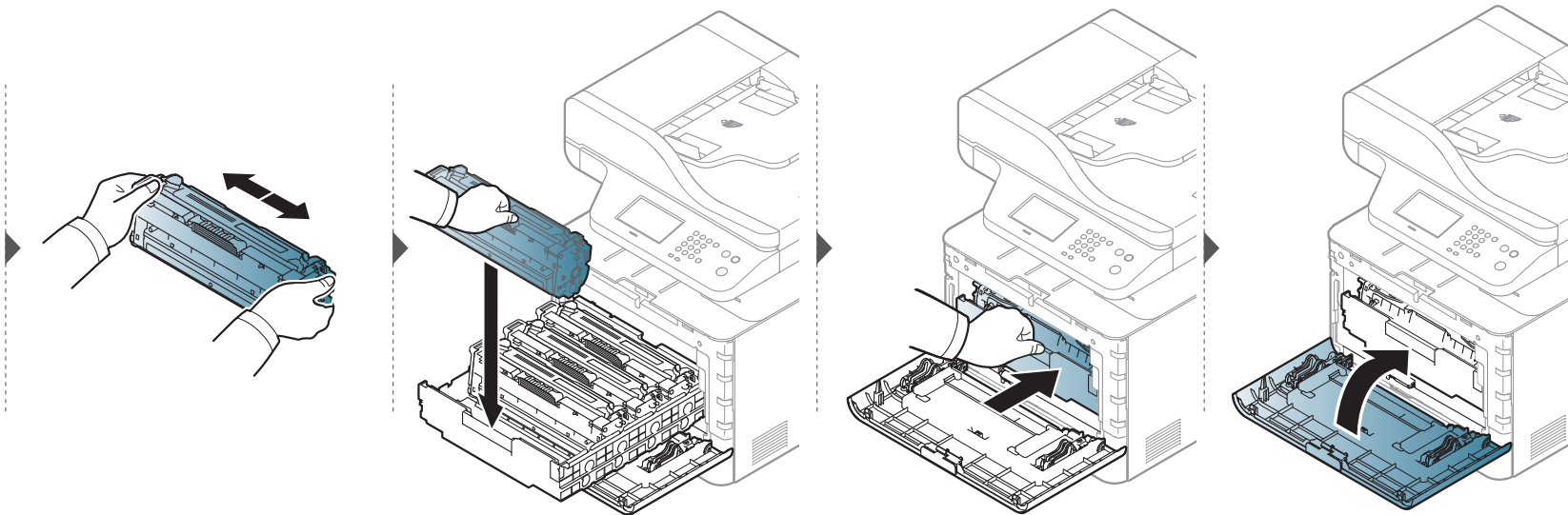
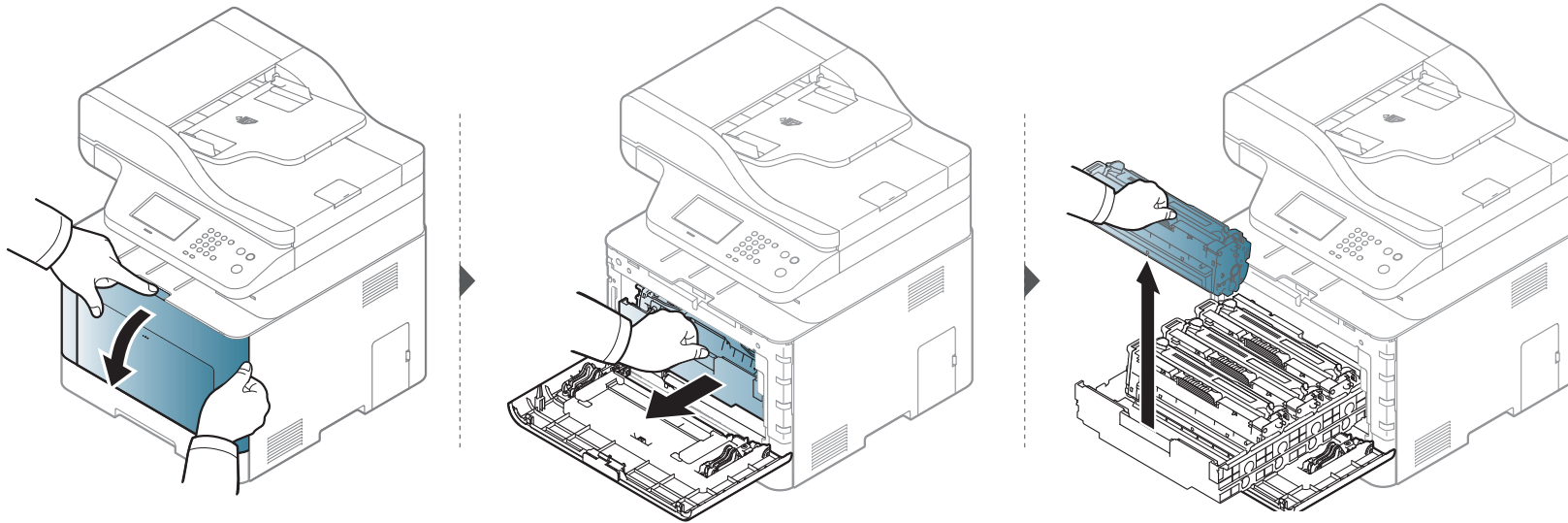

# Replacing the toner cartridge

The machine uses four colors and has a different toner cartridge for each one: yellow (Y), magenta (M), cyan (C), and black (K).

- The status LED and the toner-related message on the display indicate when each individual toner cartridge should be replaced.
- The computer's Samsung Printing Status Program window appears on the computer telling you which color cartridge is empty on toner (see "Using Samsung Printer Status" on page 312).

Check the type of the toner cartridge for your machine (see "Available supplies" on page 82).



- Shake the toner cartridge thoroughly side to side, it will increase the initial print quality.
- Illustrations on this user's guide may differ from your machine depending on its options or models. Check your machine type (see "Front view" on page 18).



- To prevent damage to the toner cartridge, do not expose it to light for more than a few minutes. Cover it with a piece of paper, if necessary.
- Do not touch the green area of the toner cartridge. Use the handle on the cartridge to avoid touching this area.
- Do not use sharp objects such as a knife or scissors to open the toner cartridge package. They might scratch the drum of the cartridge.
- If toner gets on your clothing, wipe it off with a dry cloth and wash clothing in cold water. Hot water sets toner into fabric.

# Replacing the toner cartridge

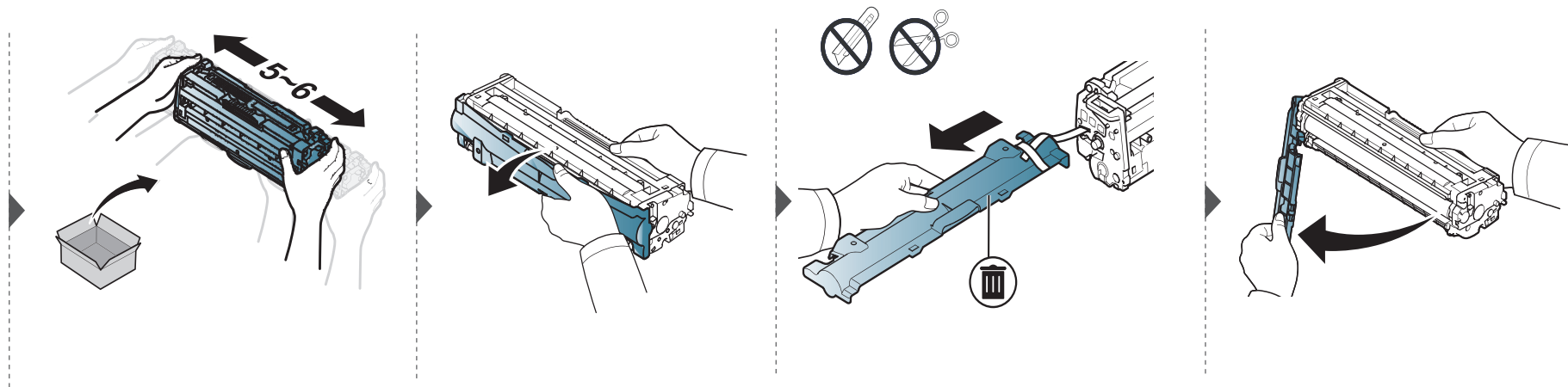
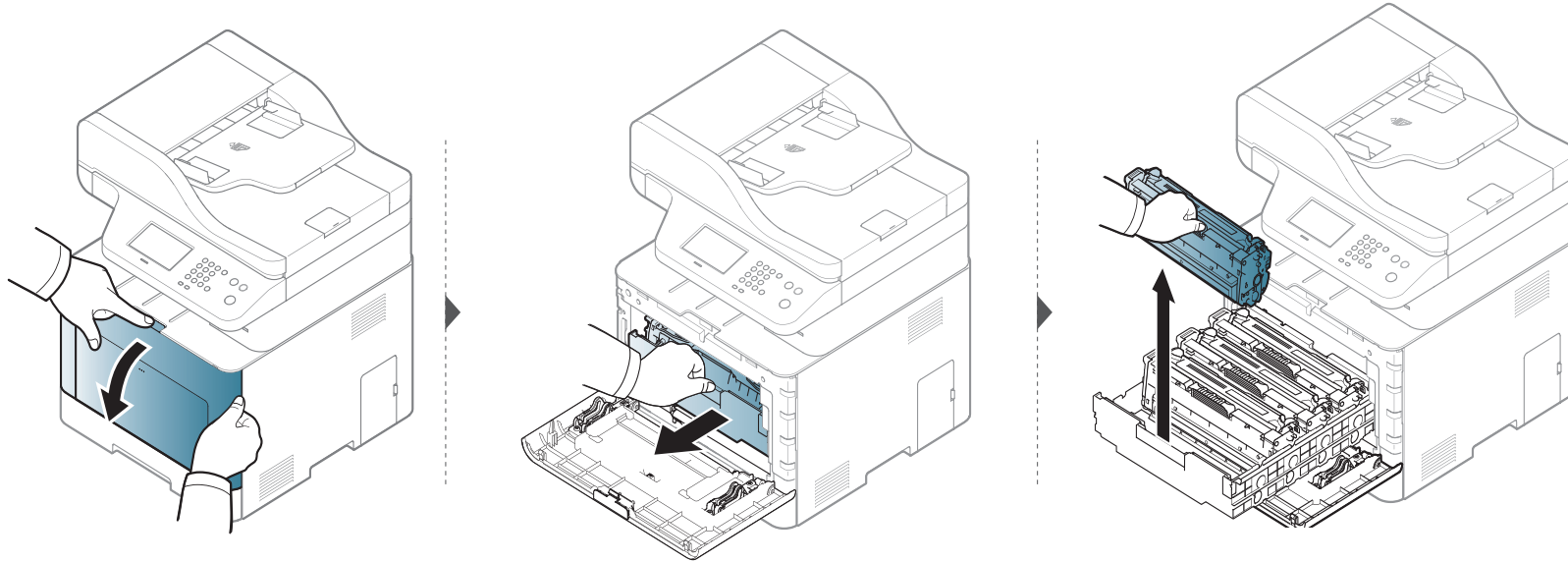

# Replacing the toner cartridge

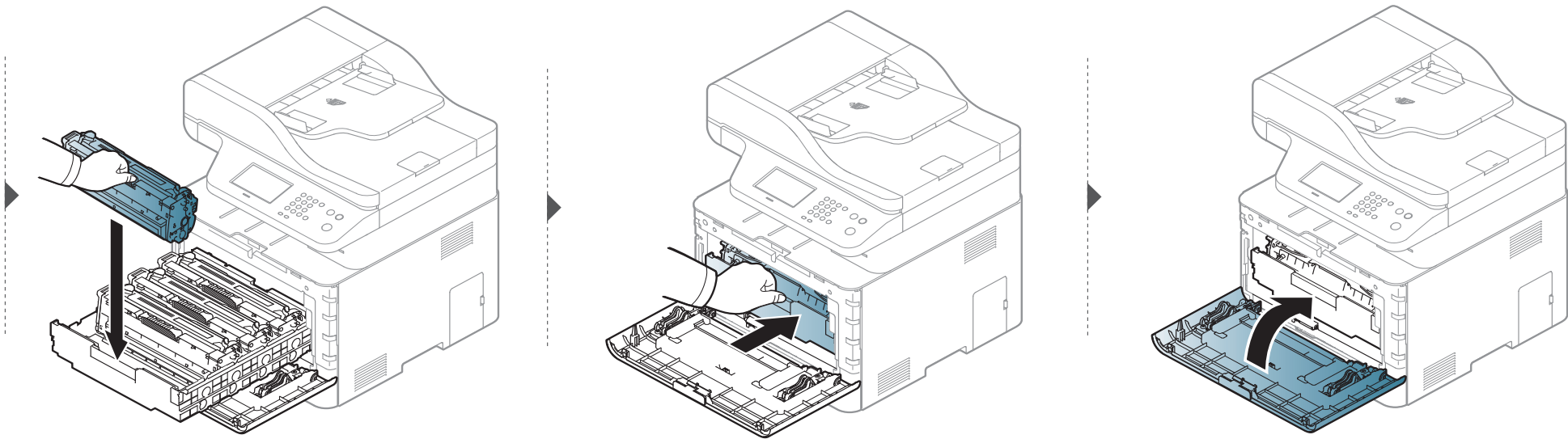

# Replacing the waste toner container

When the life span of the waste toner container has expired, waste toner container-related message appears on the screen display of the control panel, indicating the waste toner container needs to be replaced. Check the waste toner container for your machine (see "Available supplies" on page 82).



- Toner particles can be released inside the machine but it does not mean the machine is damaged. Contact a service representative when print quality problems occur.
- When you pull out the waste toner container out of the machine, move the container carefully not to drop it from your hands.
- Make sure that you lay the waste toner container on a flat surface so that the toner does not spill.



# Replacing the waste toner container



Do not tilt or turn over the container.

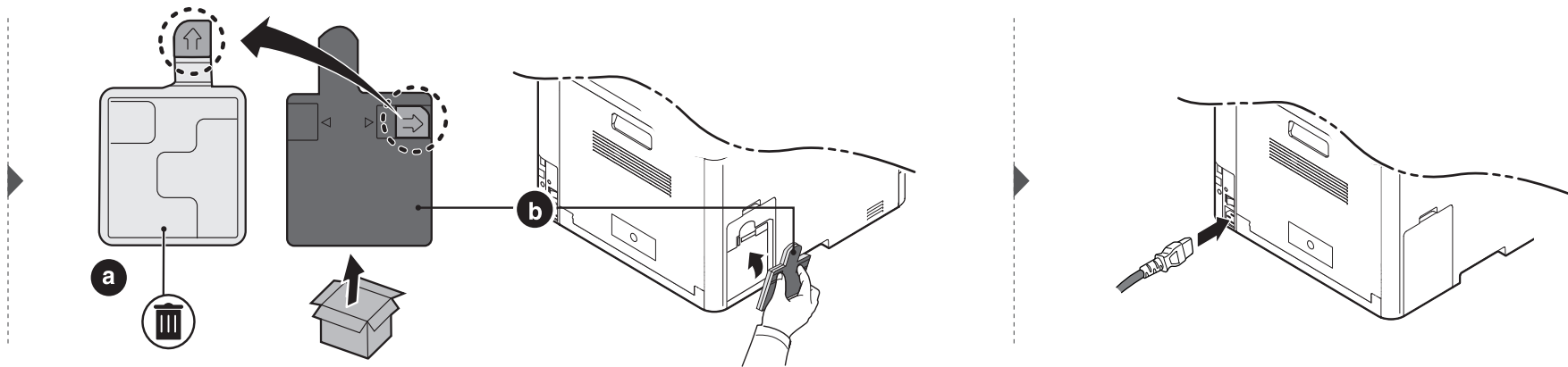
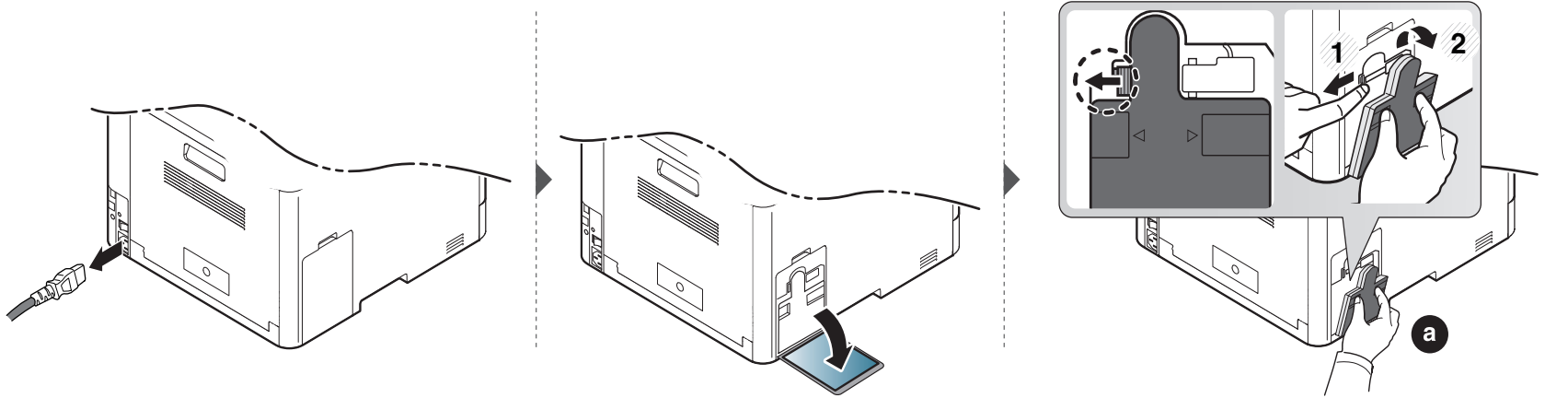

# Installing accessories

## Precautions

- Disconnect the power cord  
Never remove the control board cover while the power is turned on.  
To avoid the possibility of an electrical shock, always disconnect the power cord when installing or removing ANY internal or external accessories.
- Discharge static electricity  
The control board and internal accessories (network interface card or memory module) are sensitive to static electricity. Before installing or removing any internal accessories, discharge static electricity from your body by touching something metal, such as the metal back plate on any device plugged into a grounded power source. If you walk around before finishing the installation, repeat this procedure to discharge any static electricity again.



When installing accessories, the battery inside the machine is a service component. Do not change it by yourself. There is a risk of an explosion if battery is replaced by an incorrect type. Your service provider should remove the old battery from your device and dispose of in ordinance with state regulations.

## Setting Device Options

When you install the optional devices such as optional tray, memory, etc, this machine automatically detects and sets the optional devices. If you cannot use the optional devices you installed in this driver, you can set the optional devices in **Device Options**.

- 1 For Windows XP Service Pack 3/Server 2003, from the **Start** menu, select **Printer and Faxes**.
  - For Windows Server 2008/Vista, from the **Start** menu, select **Control Panel > Hardware and Sound > Printers**.
  - For Windows 7, from the **Start** menu, select **Control Panel > Devices and Printers**.  
For Windows 8, from the **Charms**, select **Search > Settings > Control Panel > Devices and Printers**.
  - For Windows Server 2008 R2, select **Control Panel > Hardware > Devices and Printers**.
  - For Windows 10 / Windows Server 2016  
From task bar, type in **Devices and Printers** in **Search** input area. Press the Enter key.  
OR  
From the **Start** (  ) icon, select **Settings > Devices > Printers & scanners > Devices and Printers**.

# Installing accessories



Right-click the **Start** (  ) icon, you can select **Control Panel > Devices and Printers**.

2

Right-click your machine.

3

For Windows XP/2003/2008/Vista, press **Properties**.

For Windows 7, Windows 8, and Windows Server 2008 R2, from context menus, select the **Printer properties**.



If **Printer properties** item has ► mark, you can select other printer drivers connected with selected printer.

4

Select **Device Options**.



The **Properties** window may differ depending on the driver or operating system you are using.

5

Select the appropriate option.



Some menus may not appear in the display depending on options or models. If so, it is not applicable to your machine.

- **Tray Options:** Select the optional tray you installed. You can select the tray.
- **Storage Options:** Select the optional memory you installed. If this feature is checked, you can select the **Print Mode**.
- **Advanced Features:** You can select the **Printer Status** and **Stylish User Interface**.
- **Admin Job Accounting:** Allows you to associate user and account identification information with each document you print.
  - **User permission:** If you check this option, only users with user permission can start a print job.
  - **Group permission:** If you check this option, only groups with group permission can start a print job.



If you want to encrypt job accounting password, check **Job Accounting Password Encryption**.

- **Custom Paper Size Settings:** You can specify custom paper size.

6

Click **OK** until you exit the **Properties** or **Printer properties** window.

# Monitoring the supplies life

If you experience frequent paper jams or printing problems, check the number of pages the machine has printed or scanned. Replace the corresponding parts, if necessary.



- Accessing menus may differ from model to model (see "Accessing the menu" on page 28).
- Some menus may not appear in the display depending on options or models. If so, it is not applicable to your machine.
- It may be necessary to press **OK** to navigate to lower-level menus for some models.



**1** Select  (**Menu**) > **System Setup** > **Maintenance** > **Supplies Life** on the control panel.

OR

For touch screen model, press  (**Setup**) > **Machine Setup** > **Next** > **Report** > **Supplies Information** on the touch screen.

**2** Select the option you want and press **OK**.

For the model with a touch screen, press **Yes** when the confirmation windows appears.

**3** Press the  (**Stop/Clear** or **Stop**) button or  (Home) icon to return to ready mode.

# Setting the toner low alert

If the amount of toner in the cartridge is low, a message or LED informing the user to change the toner cartridge appears. You can set the option for whether or not this message or LED appears.

 Accessing menus may differ from model to model (see "Accessing the menu" on page 28).

1 Select  (**Menu**) > **Admin Setup** > **Supplies Management** > **Toner Low Alert** > **Alert on Panel** on the control panel.

OR

For touch screen model, press  (**Setup**) > **Machine Setup** > **Next** > **Initial Setup** > **Toner Low Alert** on the touch screen.

 You can set the toner's **Warning Level** for the toner low error in the **Toner Low Alert** option. **Warning Level** means the remaining amount of toner (%) in the toner cartridge.

2 Select the option you want.

3 Press **OK** to save the selection.

For the model with a touch screen, press  (Back) to save the selection.

# Cleaning the machine

If printing quality problems occur or if you use your machine in a dusty environment, you need to clean your machine regularly to keep it in proper working order which will help to prolong its life.



- Cleaning the cabinet of the machine with cleaning materials containing large amounts of alcohol, solvents, or other strong substances can discolor or distort the cabinet.
- If your machine or the surrounding area is contaminated with toner, we recommend you use a cloth or tissue dampened with water to clean it. If you use a vacuum cleaner, toner blows in the air and might be harmful to you.

## Cleaning the outside or the display screen

Clean the machine cabinet or the display screen with a soft, lint-free cloth. Dampen the cloth slightly with water, but be careful not to let any water drip onto or into the machine.

# Cleaning the machine

## Cleaning the inside

During the printing process, paper, toner, and dust particles can accumulate inside the machine. This buildup can cause print quality problems, such as toner specks or smearing. Cleaning the inside of the machine clears and reduces these problems.



- To prevent damage to the toner cartridge, do not expose it to light for more than a few minutes. Cover it with a piece of paper, if necessary.
- Do not touch the green area of the toner cartridge. Use the handle on the cartridge to avoid touching this area.
- Use a dry lint free cloth when cleaning the inside of the machine, be careful not to damage the transfer roller or any other inside parts. Do not use solvents such as benzene or thinner. Printing quality problems can occur and cause damage to the machine.



- Use a dry lint-free cloth to clean the machine.
- Turn the machine off and unplug the power cord. Wait for the machine to cool down. If your machine has a power switch, turn the power switch off before cleaning the machine.
- Illustrations on this user's guide may differ from your machine depending on its options or models. Check your machine type (see "Front view" on page 18).

# Cleaning the machine

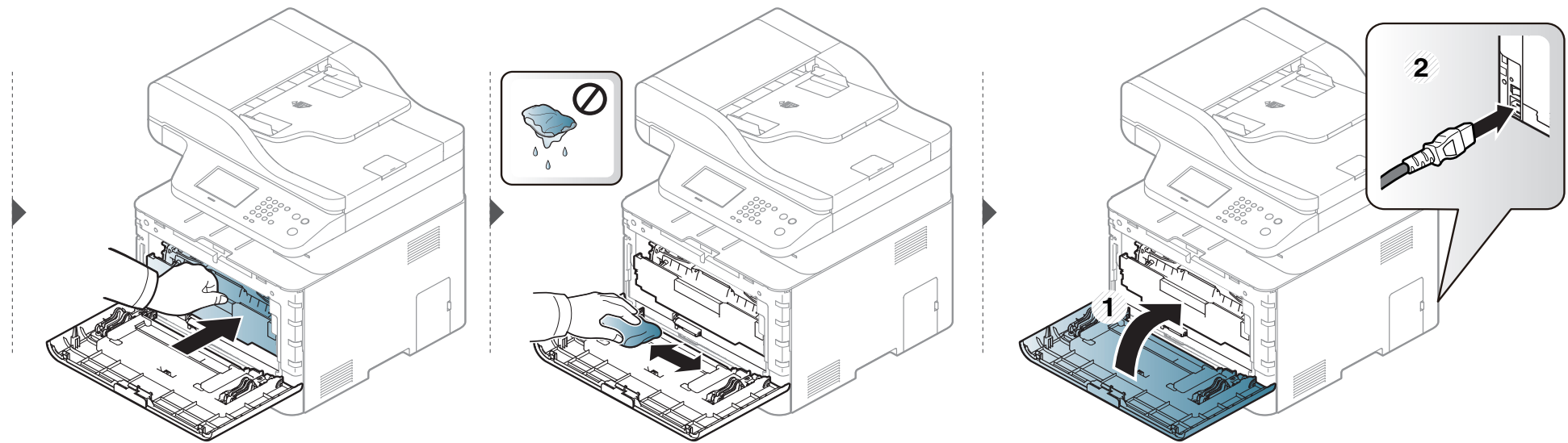
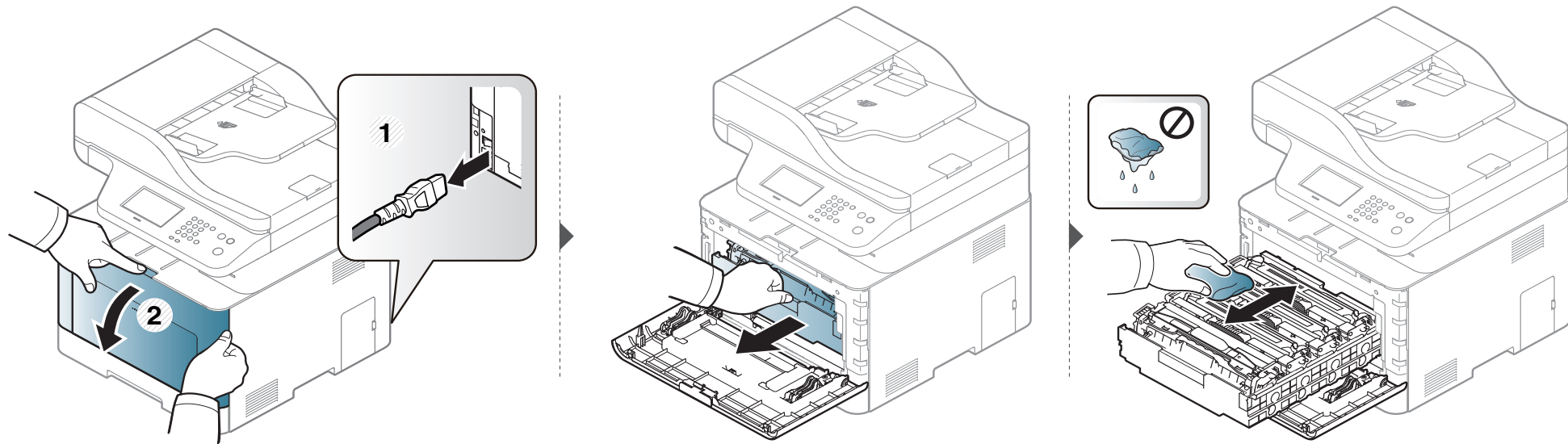



# Cleaning the machine

## Cleaning the pickup roller



- Turn the machine off and unplug the power cord. Wait for the machine to cool down. If your machine has a power switch, turn the power switch off before cleaning the machine.
- Illustrations on this user's guide may differ from your machine depending on its options or models. Check your machine type (see "Front view" on page 18).

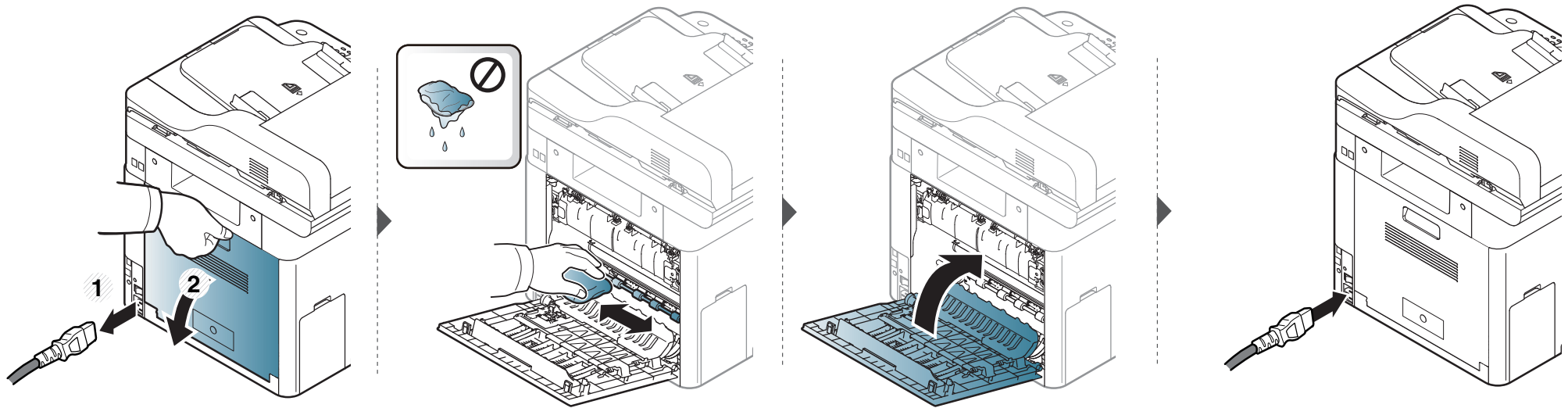

# Cleaning the machine

## Cleaning the scan unit

Keeping the scan unit clean helps ensure the best possible copies. We suggest that you clean the scan unit at the start of each day and during the day as needed.



- Turn the machine off and unplug the power cord. Wait for the machine to cool down. If your machine has a power switch, turn the power switch off before cleaning the machine.
- Illustrations on this user's guide may differ from your machine depending on its options or models. Check your machine type (see "Front view" on page 18).

- 1 Slightly dampen a soft, lint-free cloth or paper towel with water.
- 2 Lift and open the scanner lid.

# Cleaning the machine

- 3** Wipe the surface of the scanner until it is clean and dry.

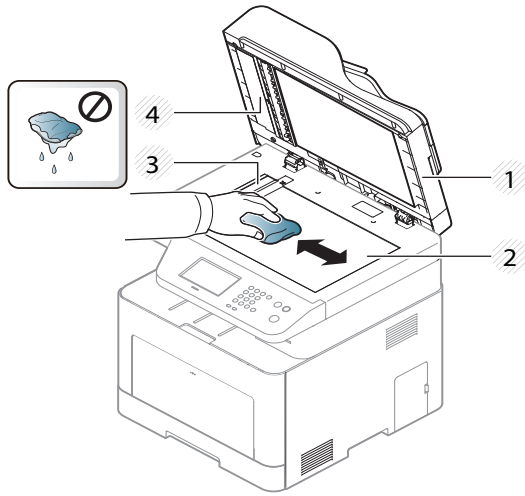

- 1** Scanner lid
- 2** Scanner glass
- 3** Document feeder glass
- 4** White bar

- 4** Close the scanner lid.

# Tips for moving & storing your machine

- When moving the machine, do not tilt or turn it upside down. Otherwise, the inside of the machine may be contaminated by toner, which can cause damage to the machine or reduce print quality.
- When moving the machine, make sure at least two people are holding the machine securely.



# 4. Troubleshooting

This chapter gives helpful information for what to do if you encounter an error.

- **Tips for avoiding paper jams** 106
- **Clearing paper jams** 107
- **Understanding the status LED** 120
- **Understanding display messages** 122



This chapter gives helpful information for what to do if you encounter an error. If your machine has a display screen, check the message on the display screen first to solve the error.

If you cannot find a solution to your problem in this chapter, refer to the **Troubleshooting** chapter in the Advanced Guide (see "Troubleshooting" on page 320).

If you cannot find a solution in the User's Guide or the problem persists, call for service.

# Tips for avoiding paper jams

By selecting the correct medias, most paper jams can be avoided. To avoid paper jams, refer to the following guidelines:

- Ensure that the adjustable guides are positioned correctly (see "Tray overview" on page 43).
- Do not remove paper from the tray while your machine is printing.
- Flex, fan, and straighten paper before loading.
- Do not use creased, damp, or highly curled paper.
- Do not mix paper type and size in a tray.
- Use only recommended print media (see "Print media specifications" on page 132).
- Remove any substances (dust, pieces of paper, tape) in the path in which paper is loaded or passes.

# Clearing paper jams

 To avoid tearing the paper, pull the jammed paper out slowly and gently.

## In tray1

 Illustrations on this user's guide may differ from your machine depending on its options or models. Check your machine type (see "Front view" on page 18).

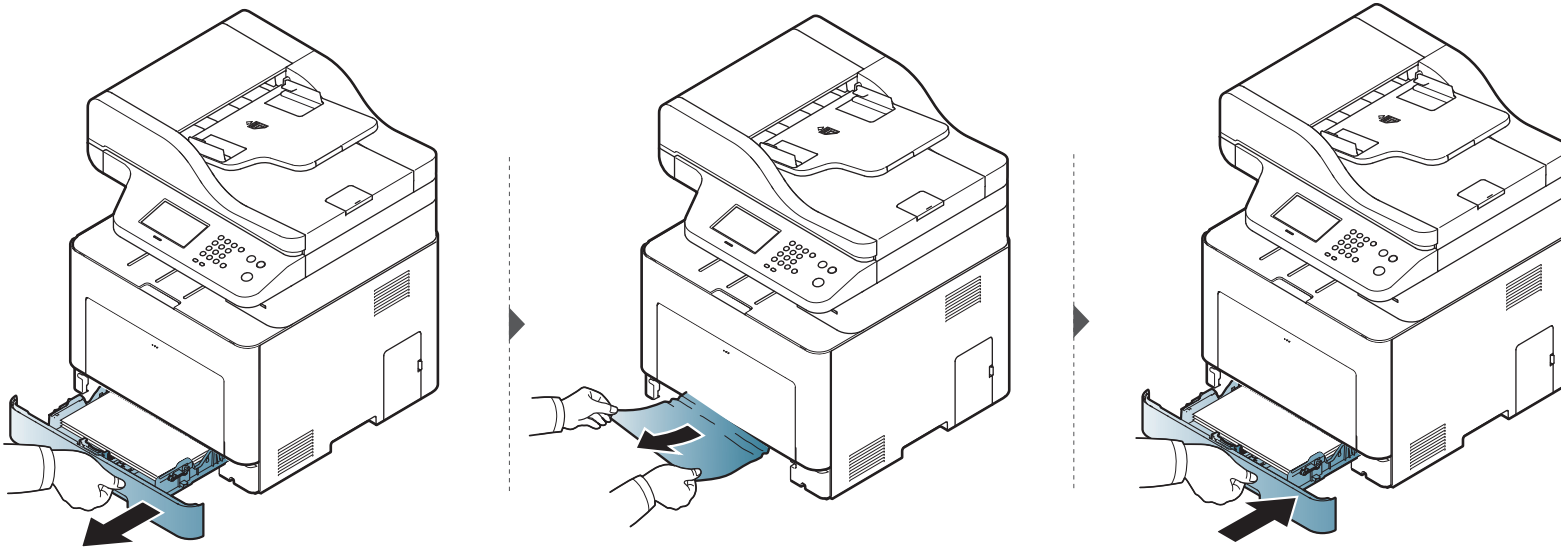

# Clearing paper jams

## In optional tray



The procedure is same for all optional trays.

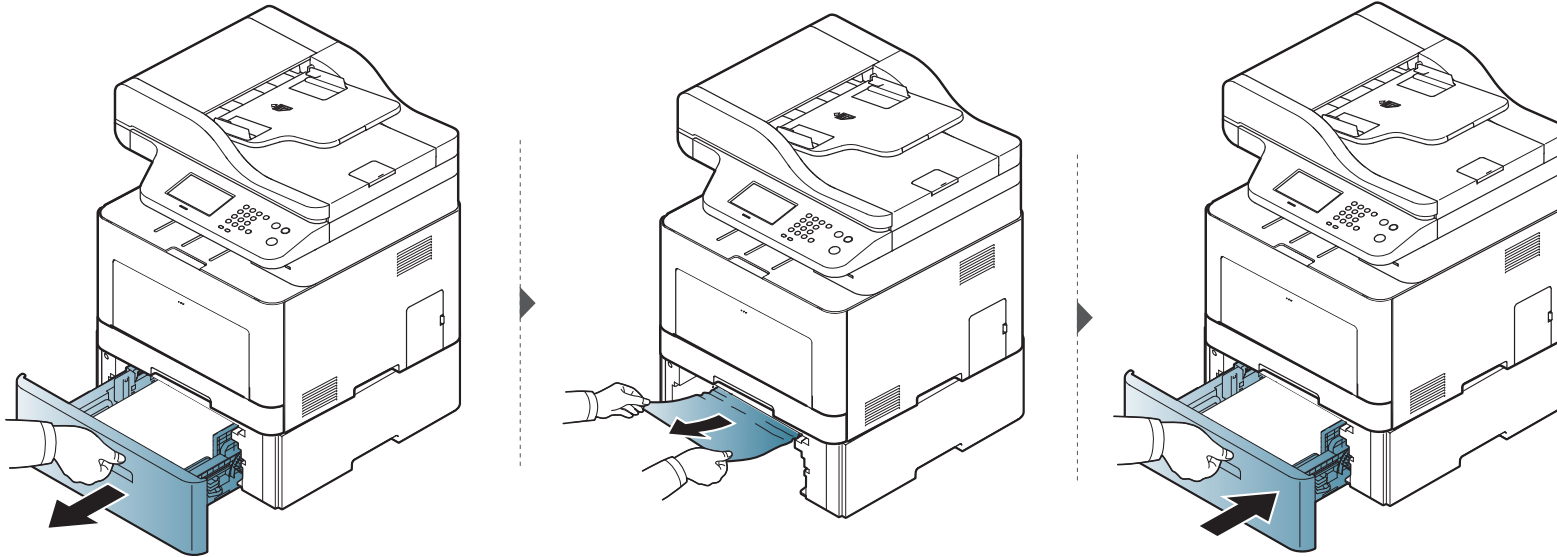



# Clearing paper jams

If you do not see the paper in this area, stop and go to next step:

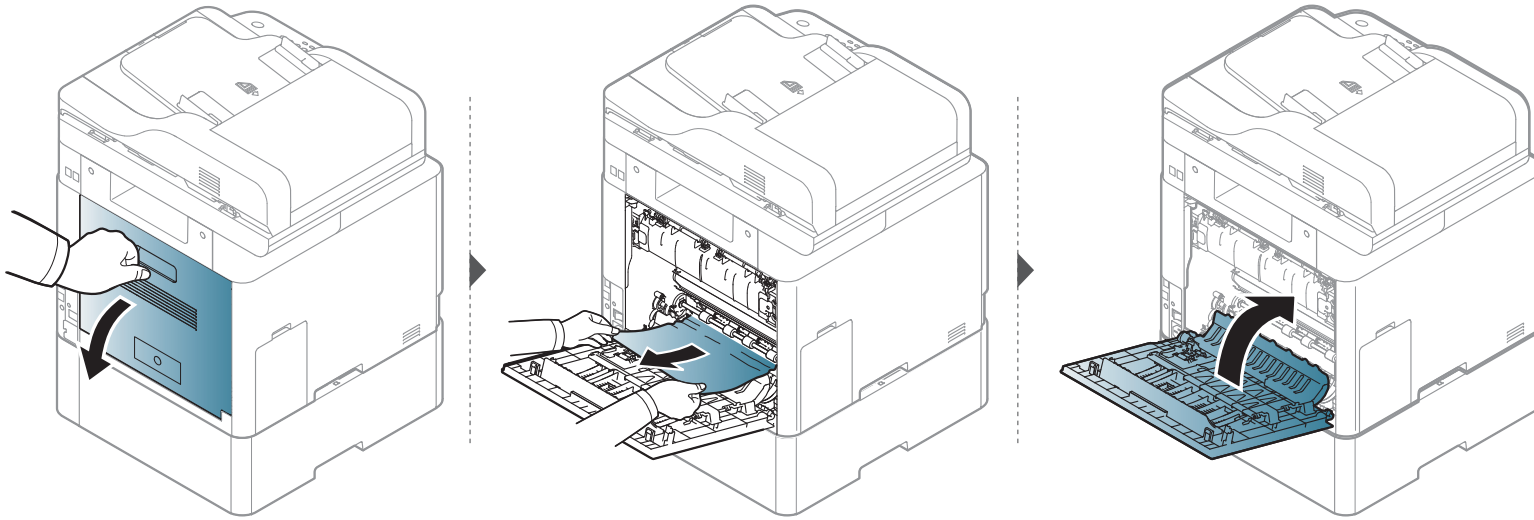

# Clearing paper jams

## In the multi-purpose tray

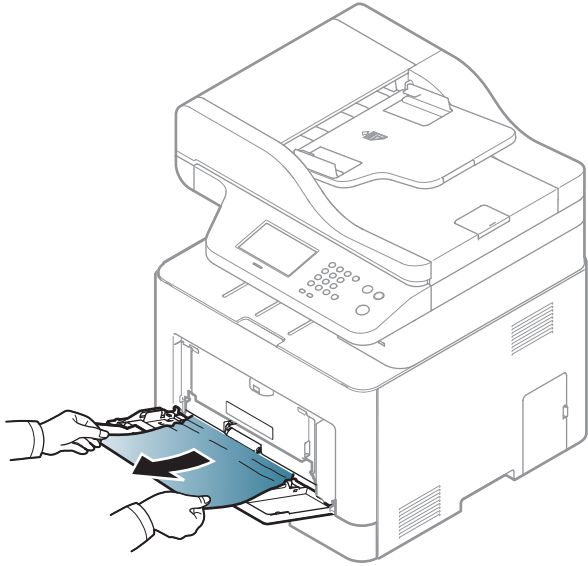

# Clearing paper jams

If you do not see the paper in this area, stop and go to next step:

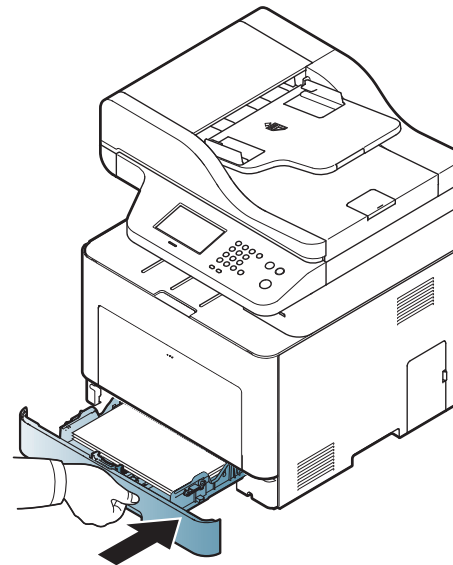
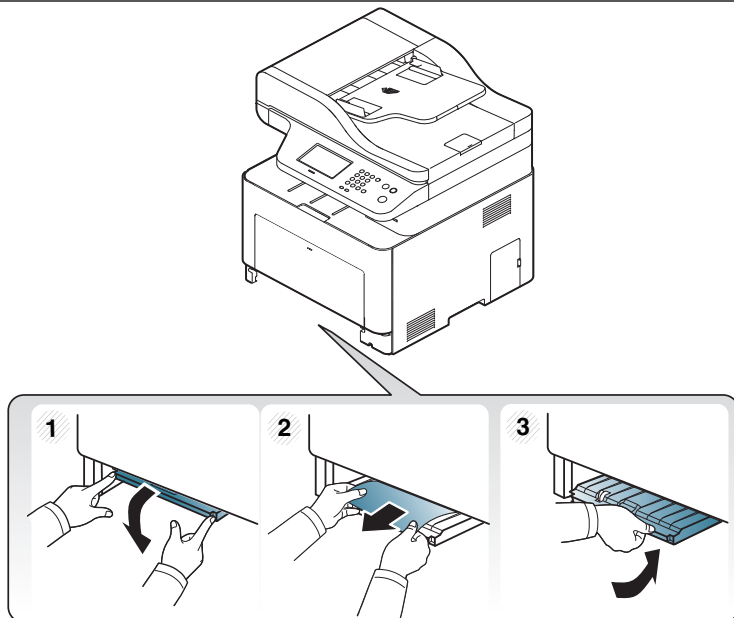
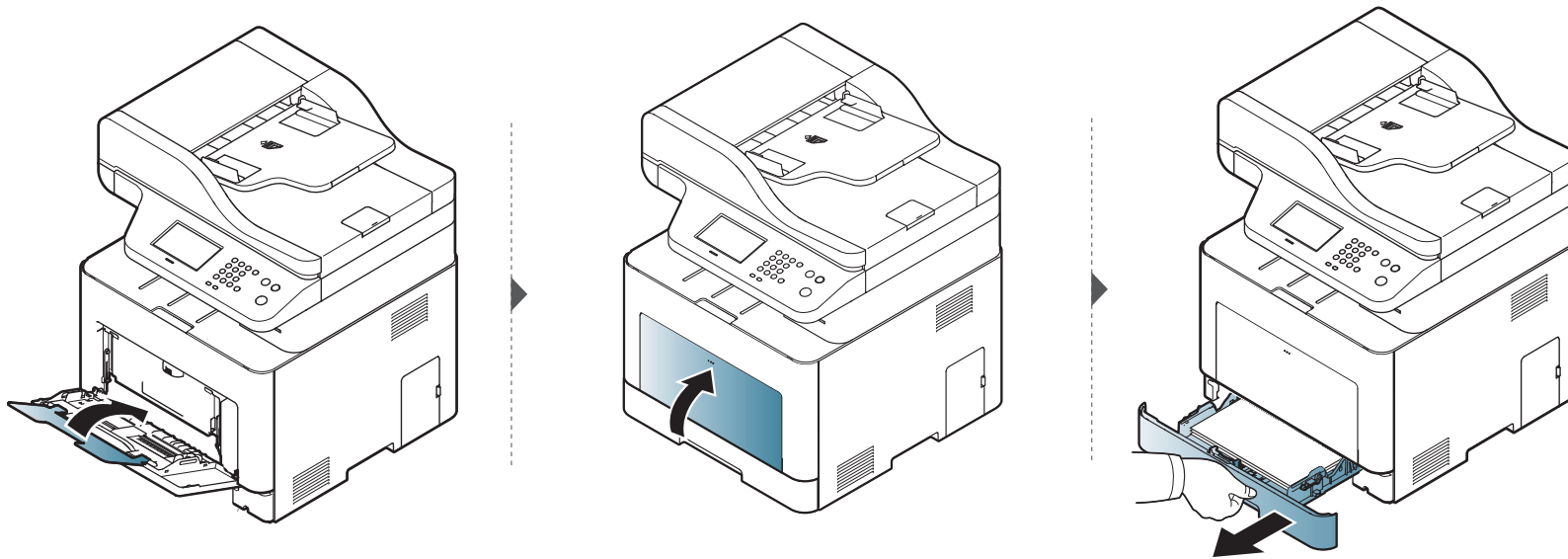

# Clearing paper jams

## Inside the machine



The fuser area is hot. Take care when removing paper from the machine.



Illustrations on this user's guide may differ from your machine depending on its options or models. Check your machine type (see "Front view" on page 18).

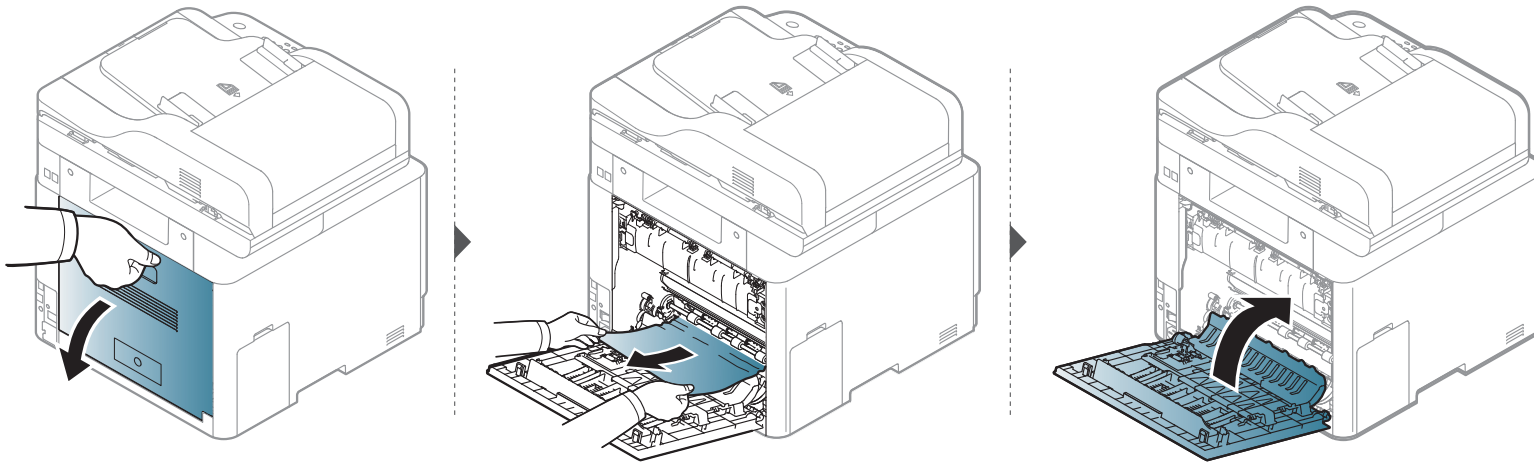

# Clearing paper jams

## In the exit area



The fuser area is hot. Take care when removing paper from the machine.

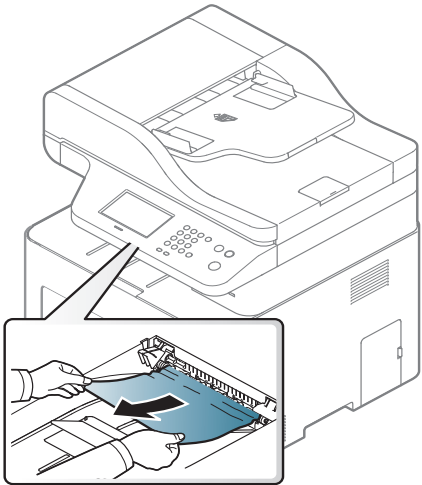

# Clearing paper jams

If you do not see the paper in this area, stop and go to next step:

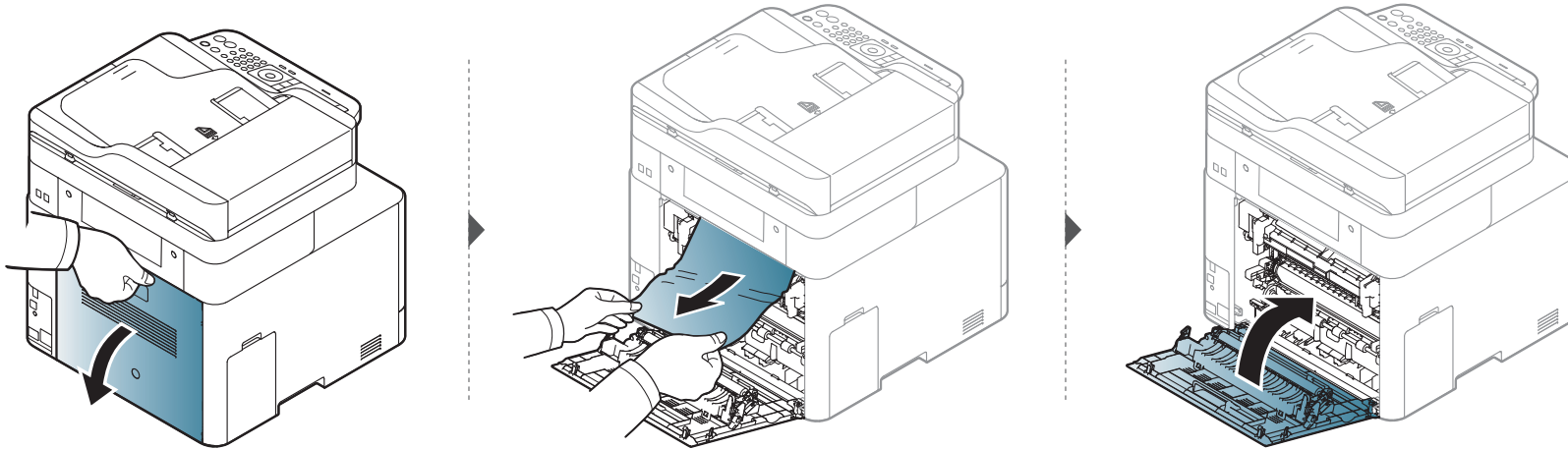

# Clearing paper jams

## In the duplex unit area

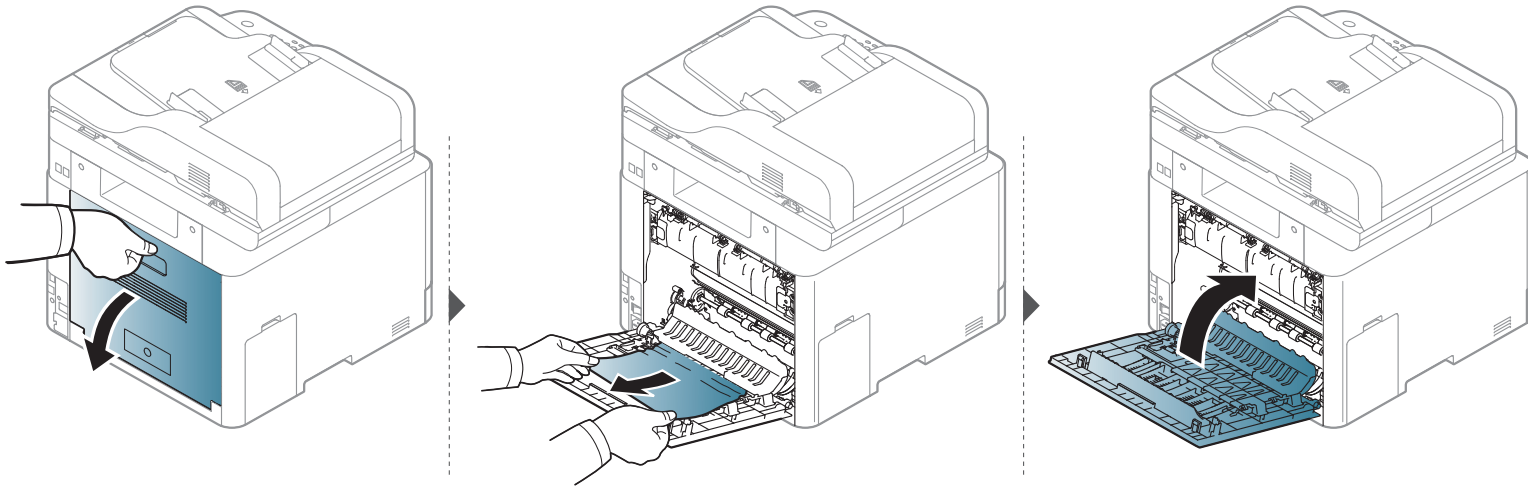

## Clearing original document jams

When an original document jams in the document feeder, a warning message appears on the display.

 To avoid tearing the document, remove the jammed document slowly and carefully.

 To prevent document jams, use the scanner glass for thick, thin or mixed paper- originals.

# Clearing paper jams

## Original paper jam in front of the document feeder



- Illustrations on this user's guide may differ from your machine depending on its options or models. Check your machine type (see "Front view" on page 18).
- This troubleshooting may not be available depending on model or optional goods (see "Variety feature" on page 8).

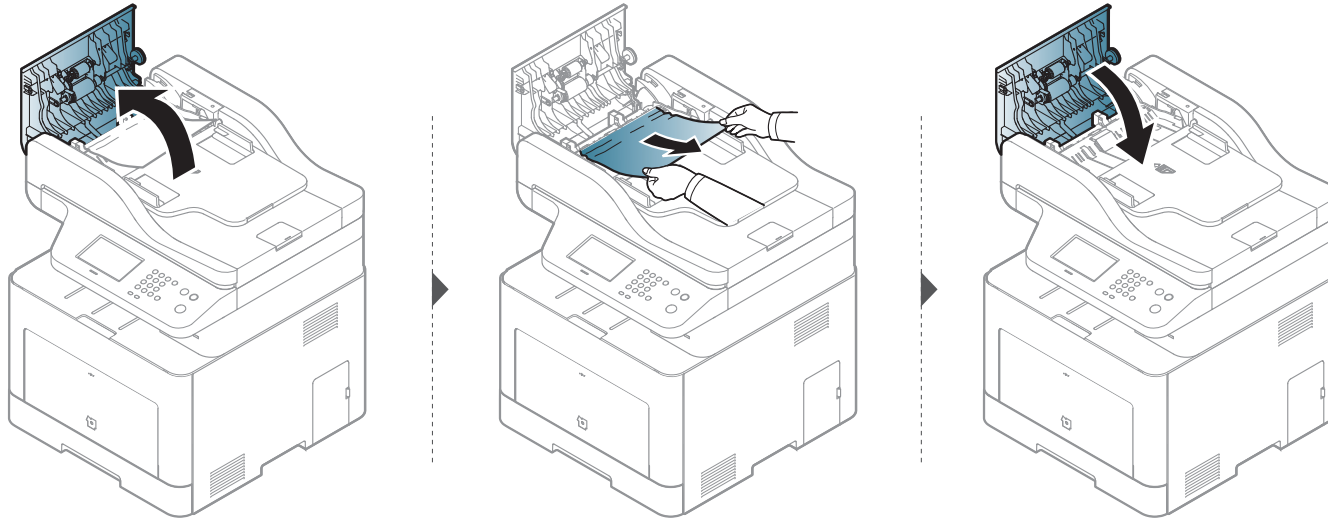



# Clearing paper jams

## Original paper jam inside of the document feeder



- Illustrations on this user's guide may differ from your machine depending on its options or models. Check your machine type (see "Front view" on page 18).
- This troubleshooting may not be available depending on model or optional goods (see "Variety feature" on page 8).

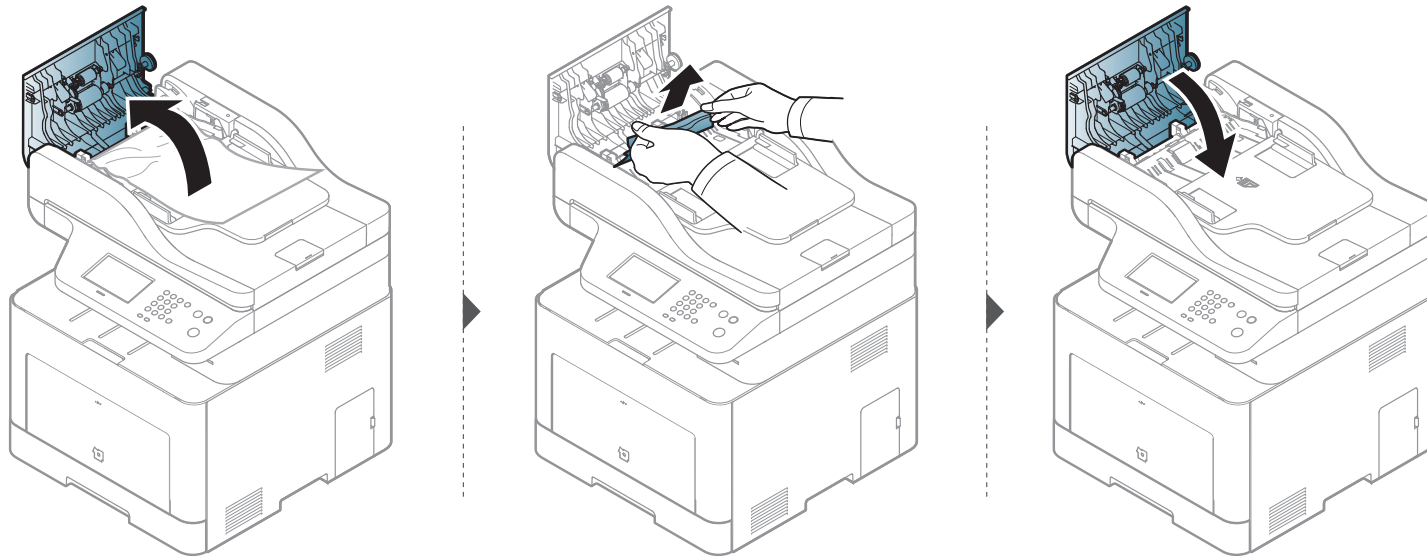

# Clearing paper jams

## Original paper jam in exit area of the document feeder



- Illustrations on this user's guide may differ from your machine depending on its options or models. Check your machine type (see "Front view" on page 18).
- This troubleshooting may not be available depending on model or optional goods (see "Front view" on page 18).

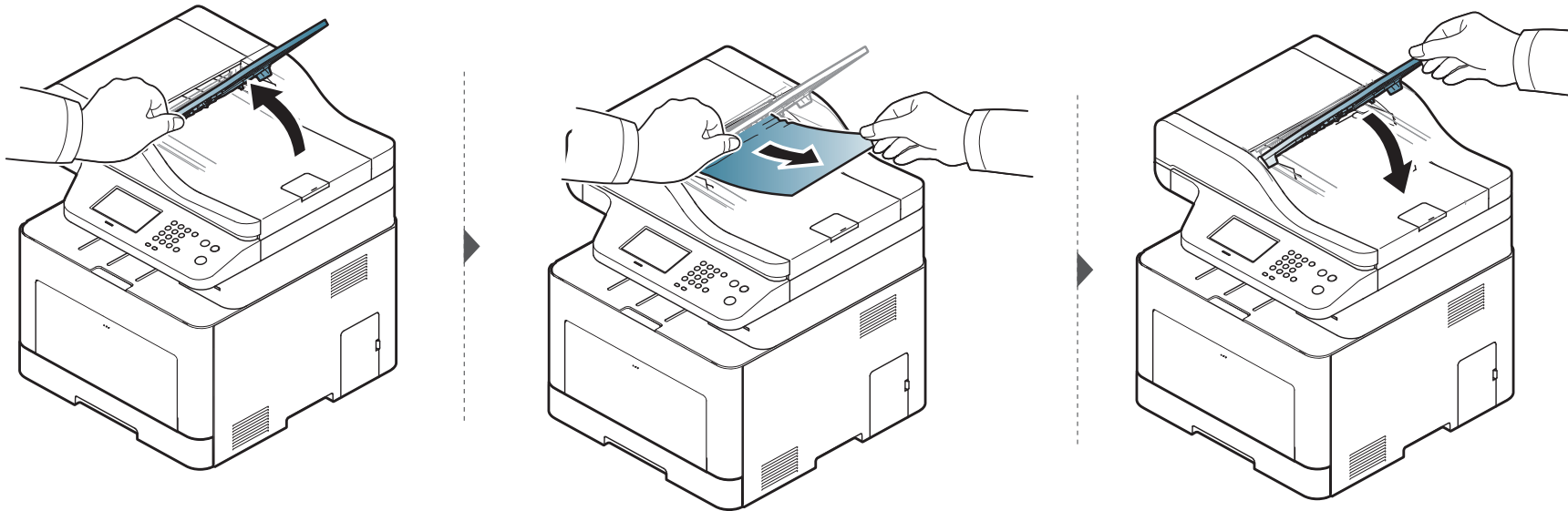

# Clearing paper jams

## Original paper jam in of the document feeder duplex path



- C306xFR and C306xFW only.
- Illustrations on this user's guide may differ from your machine depending on its options or models. Check your machine type (see "Front view" on page 18).
- This troubleshooting may not be available depending on model or optional goods (see "Front view" on page 18).

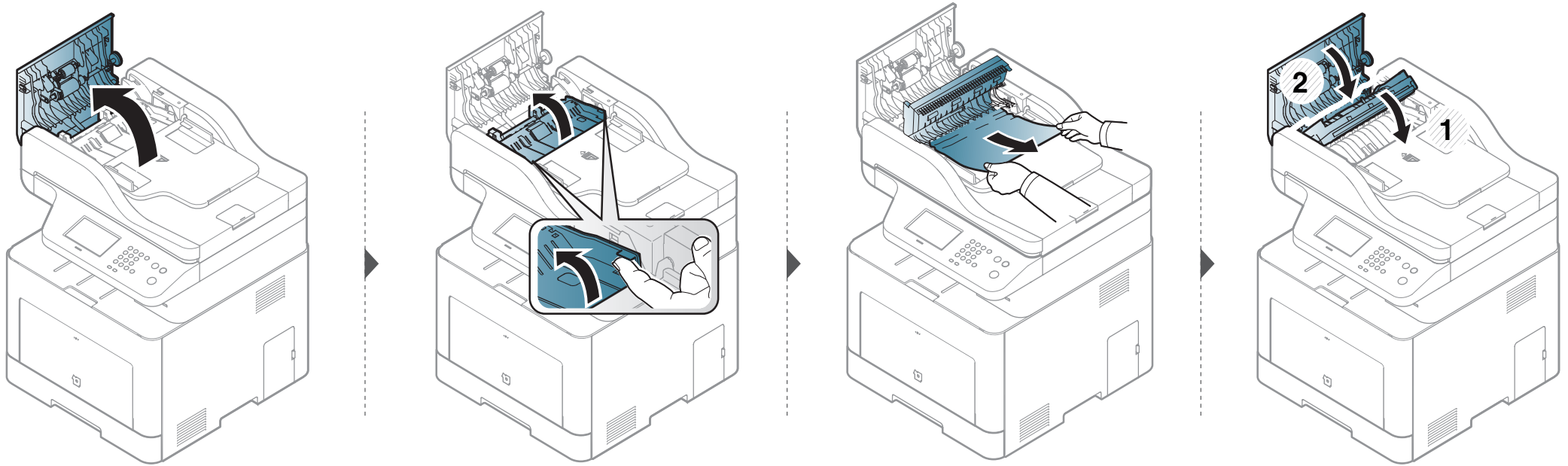

# Understanding the status LED

The color of the LED indicates the machine's current status.



- Some LEDs may not be available depending on model or country (see "Control panel overview" on page 21).
- To resolve the error, look at the error message and its instructions from the troubleshooting part (see "Understanding display messages" on page 122).
- You also can resolve the error with the guideline from the computer's Samsung Printing Status window (see "Using Samsung Printer Status" on page 312).
- If the problem persists, call a service representative.

LED	Status	Description	
Status	Off	<ul style="list-style-type: none"> <li>• The machine is off-line.</li> <li>• The machine is in power save mode.</li> </ul>	
	Blue	Blinking	When the backlight blinks, the machine is receiving or printing data.
		On	<ul style="list-style-type: none"> <li>• The machine is on-line and can be used.</li> </ul>
	Orange	Blinking	<ul style="list-style-type: none"> <li>• A minor error has occurred and the machine is waiting for the error to be cleared. Check the display message. When the problem is cleared, the machine resumes.</li> <li>• Small amount of toner is left in the cartridge. The estimated cartridge life<sup>a</sup> of toner is close. Prepare a new cartridge for replacement. You may temporarily increase the printing quality by redistributing the toner (see "Redistributing toner" on page 87).</li> </ul>
		On	<ul style="list-style-type: none"> <li>• A toner cartridge has almost reached its estimated cartridge life<sup>a</sup>. It is recommended to replace the toner cartridge (see "Replacing the toner cartridge" on page 89).</li> <li>• The cover is opened. Close the cover.</li> <li>• There is no paper in the tray. Load paper in the tray.</li> <li>• The machine has stopped due to a major error. Check the display message (see "Understanding display messages" on page 122).</li> <li>• A paper jam has occurred (see "Clearing paper jams" on page 107).</li> <li>• The waste toner container is not installed in the machine or it is full (see "Replacing the waste toner container" on page 92).</li> </ul>
			Off
( )Power /Wakeup	Blue	<ul style="list-style-type: none"> <li>On: The machine is in power save mode.</li> <li>Off: The machine is in ready mode or machine's power is off.</li> </ul>	

# Understanding the status LED

LED	Status	Description	
Eco	Green	On	Eco mode is on (see "Eco printing" on page 61).
		Off	Eco mode is off.

- a. Estimated cartridge life means the expected or estimated toner cartridge life, which indicates the average capacity of print-outs and is designed pursuant to ISO/IEC 19798. The number of pages may be affected by operating environment, percentage of image area, printing interval, graphics, media and media size. Some amount of toner may remain in the cartridge even when red LED is on and the printer stops printing.

# Understanding display messages

Messages appear on the control panel display to indicate the machine's status or errors. Refer to the tables below to understand the messages' and their meaning, and correct the problem, if necessary.



- You can resolve the error with the guideline from the computer's Printing Status program window (see "Using Samsung Printer Status" on page 312).
- If a message is not in the table, reboot the power and try the printing job again. If the problem persists, call a service representative.
- When you call for service, provide the service representative with the contents of display message.
- Some messages may not appear on the display depending on the options or models.
- [error number] indicates the error number.
- [tray number] indicates the tray number.
- [media type] indicates the media type.
- [media size] indicates the media size.
- [color] indicates the color of toner.
- [unit type] indicates the unit type.

## Paper Jam-related messages

Message	Meaning	Suggested solutions
• <b>Original paper jam inside of scanner.</b> <b>Remove jam</b>	The loaded original document has jammed in document feeder.	Clear the jam (see "Clearing original document jams" on page 115).
• <b>Paper Jam in Tray1</b>	Paper has jammed in the tray.	Clear the jam (see "In tray1" on page 107).
• <b>Paper Jam in Tray2</b>	Paper has jammed in the optional tray.	Clear the jam (see "In optional tray" on page 108).
• <b>Paper Jam in Tray3</b>		
• <b>Paper Jam in MP Tray</b>	Paper has jammed in the multi-purpose tray.	Clear the jam (see "In the multi-purpose tray" on page 110).
• <b>Paper Jam inside of machine</b>	Paper has jammed inside the machine.	Clear the jam (see "Inside the machine" on page 112).
• <b>Jam inside of duplex</b>	Paper has jammed inside the duplex area.	Clear the jam (see "In the duplex unit area" on page 115).
• <b>Jam in exit area</b>	Paper has jammed in the paper exit area.	Clear the jam (see "In the exit area" on page 113).

# Understanding display messages

## Toner-related messages

Message	Meaning	Suggested solutions
<ul style="list-style-type: none"> <li><b>Error</b> [error number] <b>Toner Cart Failure:</b> [error number] <b>Call for service</b></li> <li>[color] <b>toner not installed</b> <b>Install</b> [color] <b>toner cartridge</b></li> </ul>	<p>A toner cartridge is not installed.</p> <p>A toner cartridge is not being detected</p> <p>Protective film is not removed from toner.</p>	<p>Reinstall the toner cartridge.</p> <p>Reinstall the toner cartridge two or three times to confirm it is seated properly. If the problem persists, contact the service representatives.</p> <p>Remove the protective film from the toner cartridge. Refer to Quick Installation Guide provided with your machine.</p>
<ul style="list-style-type: none"> <li>[color]<b>toner Not Compatible</b> [color] <b>toner cartridge is not compatible.</b> <b>Check guide</b></li> </ul>	<p>The indicated toner cartridge is not suitable for your machine.</p>	<p>Install the corresponding toner cartridge with a Samsung-genuine cartridge (see "Replacing the toner cartridge" on page 89).</p>
<ul style="list-style-type: none"> <li><b>Prepare new</b> [color] <b>toner</b> <b>Prepare new</b> [color] <b>toner cartridge</b></li> </ul>	<p>Small amount of toner is left in the indicated cartridge.</p> <p>The estimated cartridge life of toner is close.</p>	<p>Prepare a new cartridge for a replacement. You may temporarily increase the printing quality by redistributing the toner (see "Redistributing toner" on page 87).</p>

Message	Meaning	Suggested solutions
<ul style="list-style-type: none"> <li><b>Replace new</b> [color] <b>toner</b> <b>Replace with new</b> [color] <b>toner cartridge</b></li> </ul>	<p>The indicated toner cartridge has almost reached its estimated cartridge life<sup>a</sup>.</p> <p>The indicated toner cartridge has reached its estimated cartridge life<sup>a</sup>.</p>	<ul style="list-style-type: none"> <li>You can choose <b>Stop</b> or <b>Continue</b> as shown on the control panel. If you select <b>Stop</b>, the printer stops printing. If you select <b>Continue</b>, the printer keeps printing but the printing quality cannot be guaranteed.</li> <li>Replace the toner cartridge for the best print quality when this message appears. Using a cartridge beyond this stage can result in printing quality issues (see "Replacing the toner cartridge" on page 89).</li> </ul> <p>Replace the toner cartridge (see "Replacing the toner cartridge" on page 89).</p>

a. Estimated cartridge life means the expected or estimated toner cartridge life, which indicates the average capacity of print-outs and is designed pursuant to ISO/IEC 19798 (see "Available supplies" on page 82). The number of pages may be affected by operating environment, percentage of image area, printing interval, media, percentage of image area, and media size. Some amount of toner may remain in the cartridge even when replace new cartridge appears and the machine stops printing.



Samsung does not recommend using a non-genuine Samsung toner cartridge such as refilled or remanufactured. Samsung cannot guarantee a non-genuine Samsung toner cartridge's quality. Service or repair required as a result of using non-genuine Samsung toner cartridges will not be covered under the machine warranty.

# Understanding display messages

## Tray-related messages

Message	Meaning	Suggested solutions
<ul style="list-style-type: none"><li>• <b>Paper in Output bin is full</b> <b>Paper in Output bin is full. Remove printed paper</b></li></ul>	The output tray is full.	Remove papers from the output tray, the printer resumes printing.
<ul style="list-style-type: none"><li>• <b>Paper Empty in tray 1</b> <b>Paper is empty in tray 1.</b> <b>Load paper</b></li></ul>	There is no paper in tray 1.	Load paper in tray 1 (see "Tray 1 / optional tray" on page 44).
<ul style="list-style-type: none"><li>• <b>Paper Empty in tray 2</b> <b>Paper is empty in tray 2.</b> <b>Load paper</b></li></ul>	There is no paper in optional tray.	Load paper in tray 2 (see "Tray 1 / optional tray" on page 44).
<ul style="list-style-type: none"><li>• <b>Paper Empty in tray 3</b> <b>Paper is empty in tray 3.</b> <b>Load paper</b></li></ul>		
<ul style="list-style-type: none"><li>• <b>Paper Empty in MP</b> <b>Paper is empty in MP tray.</b> <b>Load paper</b></li></ul>	There is no paper in the multi-purpose tray.	Load paper in the multi-purpose tray (see "Multi-purpose tray" on page 46).

Message	Meaning	Suggested solutions
<ul style="list-style-type: none"><li>• <b>Paper mismatch</b> [tray type]</li><li>• <b>Paper mismatch MPT</b></li></ul>	The paper size specified in the printer properties does not match the paper loaded in the tray.	Select <b>Continue</b> to proceed with the print job with the incorrect paper, or select <b>Cancel</b> to stop the print job and load the correct paper in the tray.

## Network-related messages

Message	Meaning	Suggested solutions
<ul style="list-style-type: none"><li>• <b>IP Conflict</b> <b>This IP address conflicts with that of other system</b></li></ul>	The network IP address you have set is being used by someone else.	Check the IP address and reset it if necessary.
<ul style="list-style-type: none"><li>• <b>802.1x Network Error</b> <b>802.1x Network Error.</b> <b>Contact the Admin</b></li></ul>	Fail to authenticate.	Check the network authentication protocol. If the problem persists, contact your network administrator.



# Understanding display messages

Message	Meaning	Suggested solutions
<ul style="list-style-type: none"><li>• <b>Error:</b> [error number] <b>Network Failure:</b> [error number] <b>Turn off then on.</b> <b>Call for service if the problem persists</b></li></ul>	There is a problem in the network system.	Turn the machine off and back on again. If the problem persists, call for service.
<ul style="list-style-type: none"><li>• <b>Error:</b> [error number] <b>Can not find a wireless network. Please check the wireless environment</b></li></ul>	The machine cannot find the wireless network.	Check the status of the wireless router or access point, including its configuration and power connections, as well as any devices that may affect wireless communication. If the problem persists, please call for service.

Message	Meaning	Suggested solutions
<ul style="list-style-type: none"><li>• <b>Error:</b> [error number] <b>Wireless security settings are incorrect. Please change the settings</b></li></ul>	<ul style="list-style-type: none"><li>• The wireless network options are configured incorrectly for the security method.</li><li>• The password entered in the wireless security options is incorrect.</li><li>• The machine does not support the security method used by the access point or wireless router.</li><li>• The access point or wireless router has malfunctioned.</li></ul>	Reconfigure the wireless options in the machine, SyncThru™ Web Service, access point (or wireless router). The WPA2-PSK/AES security method is recommended. If the problem persists, please call for service.
<ul style="list-style-type: none"><li>• <b>Error:</b> [error number] <b>Not connected from the wireless AP. If you do not reconnect automatically, check the wireless settings</b></li></ul>	The machine failed to connect to the wireless access point (or wireless router).	Check the status of the access point, including its configuration and power connections, as well as any devices that may affect wireless communication. If the problem persists, please call for service.

# Understanding display messages

Message	Meaning	Suggested solutions
<ul style="list-style-type: none"> <li><b>Error:</b> [error number] <b>Failed connection to WPS. Try again or set up other wireless connection</b></li> </ul>	The machine failed to connect via WPS.	Check the WPS settings (see "Using the WPS menu" on page 177).
<ul style="list-style-type: none"> <li><b>Error:</b> [error number] <b>Wi-Fi Direct is not ready. Turn off then on. Call for service if the problem persists</b></li> </ul>	The machine failed to initialize the Wi-Fi Direct connection.	Reboot the machine to initialize the wireless settings. If the problem persists, please call for service.
<ul style="list-style-type: none"> <li><b>Error:</b> [error number] <b>Failed to connect to Wi-Fi Direct. Turn off your mobile device and turn it on</b></li> </ul>	The machine failed to connect via Wi-Fi Direct.	Turn the Wi-Fi Direct feature off and then back on or reboot the machine or mobile device. If the problem persists, please call for service.

## Misc. messages

Message	Meaning	Suggested solutions
<ul style="list-style-type: none"> <li><b>Door is open. Close it</b></li> </ul>	The front cover or rear cover is not securely latched.	Close the cover until it locks into place.

Message	Meaning	Suggested solutions
<ul style="list-style-type: none"> <li><b>Scanner door open</b> <b>Door of scanner is open. Close the door</b></li> </ul>	The document feeder cover is not securely latched.	Close the cover until it locks into place.
<ul style="list-style-type: none"> <li><b>Error:</b> [error number] [unit type] <b>Failure:</b> [error number] <b>Turn off then on. Call for service if the problem persists</b></li> <li><b>Error:</b> [error number] [unit type] <b>Failure:</b> [error number] <b>Turn off then on</b></li> </ul>	The machine unit cannot be controlled.	Reboot the power and try the printing job again. If the problem persists, please call for service.
<ul style="list-style-type: none"> <li><b>Not proper Room Temp</b> <b>The room temperature is not suitable for this set use. Please adjust room temperature</b></li> </ul>	The machine is in a room with improper room temperature.	Move the machine to a room with proper room temperature (see "Specifications" on page 130).
<ul style="list-style-type: none"> <li><b>Prepare TR. belt</b> <b>Prepare new image transfer belt unit</b></li> </ul>	The life of the transfer belt has expired.	Replace the transfer belt with a new one. Contact the service representatives.
<ul style="list-style-type: none"> <li><b>Prepare fuser unit</b> <b>Prepare new fuser unit</b></li> </ul>	The estimated life of the fuser unit is close.	Replace the fuser unit with a new one. Contact the service representatives.

# Understanding display messages

Message	Meaning	Suggested solutions
<ul style="list-style-type: none"> <li>• <b>Replace Fuser unit</b> <b>Replace with new fuser unit</b></li> </ul>	The life of the fuser unit will be expired.	Replace the fuser unit with a new one. Contact the service representatives.
<ul style="list-style-type: none"> <li>• <b>Install TR. belt unit</b> <b>Install transfer belt unit</b></li> </ul>	The transfer belt is not installed.	Install a Samsung-genuine transfer belt. Contact the service representatives.
<ul style="list-style-type: none"> <li>• <b>TR belt Not compatible transfer belt unit is not compatible.</b> <b>Check guide.</b></li> </ul>	The transfer belt of the machine is not for your machine.	Install the a Samsung-genuine part designed for your machine. Contact the service representatives.
<ul style="list-style-type: none"> <li>• <b>Waste toner Near Full</b> <b>Waste toner container is almost full.</b> <b>Replace with new one</b></li> </ul>	The life span of the waste toner container has expired and the printer will stop printing until a new waste toner container is placed into the printer.	Replace a waste toner container with a Samsung-genuine waste toner container.
<ul style="list-style-type: none"> <li>• <b>Waste tank Full</b> <b>Waste toner tank is full.</b> <b>Replace with new one</b></li> </ul>	The waste toner container is full.	Replace the waste toner container.

Message	Meaning	Suggested solutions
<ul style="list-style-type: none"> <li>• <b>Waste Not Installed</b> <b>Waste toner tank is not installed. install it</b></li> </ul>	The waste toner container is not installed.	Install the waste toner container. If it is already installed, try to reinstall the waste toner container. If the problem persists, call for service.
<ul style="list-style-type: none"> <li>• <b>Replace pickup roller</b> <b>Replace with new</b> [tray type] <b>pickup roller</b></li> </ul>	The life of the tray1, tray2 or MP tray pick-up roller will expired soon.	Replace the tray pick-up roller with a new one. Contact the service representatives.
<ul style="list-style-type: none"> <li>• <b>Replace retard roller</b> <b>Replace with new</b> [tray type] <b>retard roller</b></li> </ul>	The life of the tray1 or tray2 retard roller has expired.	Replace the tray retard roller with a new one. Contact the service representatives.
<ul style="list-style-type: none"> <li>• <b>Memory Full</b> <b>Fax memory is almost full.</b> <b>Print or remove received fax job</b></li> </ul>	The fax memory is almost full.	Print or remove the received fax job in <b>Secure Receive.</b>
<ul style="list-style-type: none"> <li>• <b>Memory Full</b> <b>Fax memory is full.</b> <b>Print or remove received fax job</b></li> </ul>	The memory is full. No more fax data can be received.	Print or remove the received fax data in the memory.

# Understanding display messages

Message	Meaning	Suggested solutions
<ul style="list-style-type: none"><li>• <b>Scanner Locked</b> <b>Scanner is locked. Press Stop button</b></li></ul>	The scanner is locked.	Reboot the power. If the problem persists, please call for service.
<ul style="list-style-type: none"><li>• <b>Error:</b> [error number] <b>Fax Failure:</b> [error number] <b>Turn off then on. Call for service if the problem persists</b></li></ul>	There is a problem in the fax system.	Install the fax card. If it is already installed, try to reinstall the fax card. If the problem persists, call for service.
<ul style="list-style-type: none"><li>• <b>Error:</b> [error number] <b>Engine System Failure:</b> [error number] <b>Call for service</b></li></ul>	There is a problem in the engine system.	Unplug the power cord and plug it back in. If the problem persists, call for service.
<ul style="list-style-type: none"><li>• <b>Error:</b> [error number] <b>Sensor Failure:</b> [error number] <b>Turn off then on</b></li></ul>	There is a problem in the sensor.	Unplug the power cord and plug it back in. If the problem persists, call for service.
<ul style="list-style-type: none"><li>• <b>Error:</b> [error number] <b>HDD System Failure:</b> [error number] <b>Turn off then on. Call for service if the problem persists</b></li></ul>	There is a problem in the HDD system.	Reboot the power. If the problem persists, please call for service.



# 5. Appendix

This chapter provides product specifications and information concerning applicable regulations.

- **Specifications** 130
- **Regulatory information** 140
- **Copyright** 153

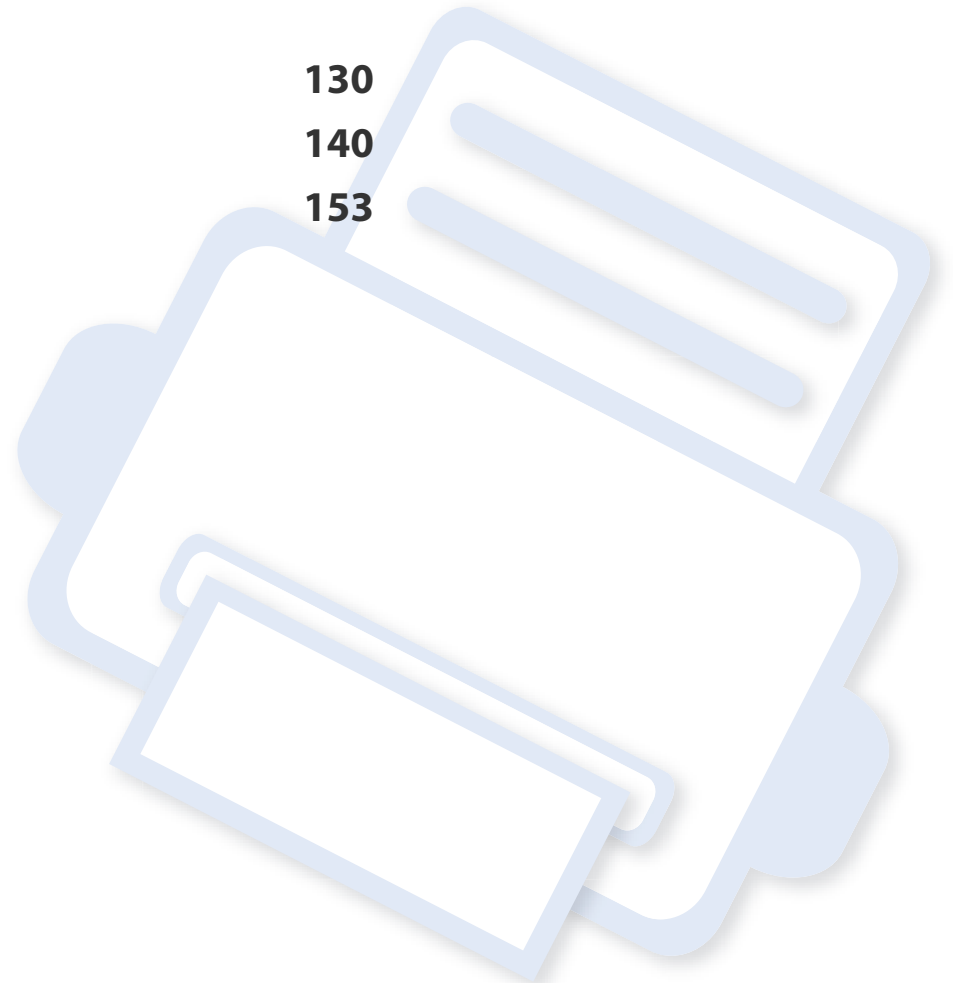

# Specifications

## General specifications



These specifications are subject to change without notice. To see additional specifications and information about changes to the specifications, please visit, [www.samsung.com](http://www.samsung.com).

Items		Description	
Dimension <sup>a</sup>	Width x Depth x Height	<ul style="list-style-type: none"><li>• <b>C306xND:</b> 420 x 452.5 x 476.8 mm (16.54 x 17.82 x 18.77 inches)</li><li>• <b>C306xFR / C306xFW:</b> 469 x 452.5 x 504.3 mm (18.47 x 17.82 x 99.85 inches)</li></ul>	
	Machine with supplies	<ul style="list-style-type: none"><li>• <b>C306xND:</b> 24.62 kg (54.28 lbs)</li><li>• <b>C306xFR / C306xFW:</b> 26.32 kg (58.02 lbs)</li></ul>	
Noise Level <sup>bc</sup>	Ready mode	Less than 37 dB (A)	
	Print mode	Less than 52 dB (A)	
	Copy mode	Tray 1	Less than 54 dB (A)
		Tray 2	Less than 55 dB (A)
	Scan mode	Scanner glass	Less than 50 dB (A)
Document feeder		Less than 52 dB (A)	
Temperature	Operation	10 to 30 °C (50 to 86 °F)	
	Storage (packed)	-20 to 40 °C (-4 to 104 °F)	

# Specifications

Items		Description
<b>Humidity</b>	<b>Operation</b>	20 to 80 % RH
	<b>Storage (packed)</b>	10 to 90 % RH
<b>Power rating<sup>d</sup></b>	<b>110 volt models</b>	AC 110 - 127 V
	<b>220 volt models</b>	AC 220 - 240 V
<b>Power consumption<sup>e</sup></b>	<b>Average operating mode</b>	Less than 500 W
	<b>Ready mode</b>	Less than 40 W
	<b>Power save mode</b>	<ul style="list-style-type: none"> <li>• <b>C306xND / C306xFR</b> : Less than 1.4 W</li> <li>• <b>C306xFW</b>: Less than 1.8 W</li> </ul>
	<b>Power off mode<sup>f</sup></b>	Less than 0.5 W (0.1 W <sup>g</sup> )
<b>Wireless<sup>h</sup></b>	<b>Module</b>	SPW-B4319U

a. Dimensions and weight are measured without a handset.

b. Sound Pressure Level, ISO 7779. Configuration tested: basic machine installation, A4 paper, simplex printing.

c. China only: If the equipment's noise is louder than 63 dB (A) ,the equipment should be placed in region of relatively independent advice.

d. See the rating label on the machine for the correct voltage (V), frequency (hertz) and of current (A) for your machine.

e. The power consumption may be affected by the machine's status, setting conditions, operating environment, and measuring equipment and method the country uses.

f. Power consumption can be completely avoided only when the power cable is not connected.

g. Korea only.

h. C306xFW only.

# Specifications

## Print media specifications

Type	Size	Dimensions	Weight/Capacity <sup>a</sup>	
			Tray1/ Optional tray	Multi-purpose tray
Plain paper <sup>bc</sup>	<b>Letter</b>	216 x 279 mm (8.5 x 11 inches)	70 to 90 g/m <sup>2</sup> (19 to 24 lbs bond)	70 to 90 g/m <sup>2</sup> (19 to 24 lbs bond)
	<b>Legal</b>	216 x 356 mm (8.5 x 14 inches)	<ul style="list-style-type: none"> <li>• Tray1: 250 sheets of 75 g/m<sup>2</sup> (20 lbs bond)</li> <li>• Optional tray: 550 sheets of 75 g/m<sup>2</sup> (20 lbs bond)</li> </ul>	<ul style="list-style-type: none"> <li>• 50 sheets</li> </ul>
	<b>US Folio</b>	216 x 330 mm (8.5 x 13 inches)		
	<b>A4</b>	210 x 297 mm (8.27 x 11.69 inches)		
	<b>Oficio</b>	216 x 343 mm (8.5 x 13.5 inches)		
	<b>JIS B5</b>	182 x 257 mm (7.17 x 10.12 inches)		
	<b>ISO B5</b>	176 x 250 mm (6.93 x 9.84 inches)		
	<b>Executive</b>	184 x 267 mm (7.25 x 10.5 inches)		
	<b>Statement</b>	140 x 216 mm (5.5 x 8.5 inches)		
	<b>A5</b>	148 x 210 mm (5.83 x 8.27 inches)		
	<b>A6</b>	105 x 148 mm (4.13 x 5.83 inches)	70 to 90 g/m <sup>2</sup> (19 to 24 lbs bond)	70 to 90 g/m <sup>2</sup> (19 to 24 lbs bond)
			<ul style="list-style-type: none"> <li>• 150 sheets of 75 g/m<sup>2</sup> (20 lbs bond)</li> </ul> Not available in optional tray.	



# Specifications

Type	Size	Dimensions	Weight/Capacity <sup>a</sup>	
			Tray1/ Optional tray	Multi-purpose tray
Envelope	Envelope Monarch	98 x 191 mm (3.87 x 7.5 inches)	75 to 90 g/m <sup>2</sup> (20 to 24 lbs bond) • 20 sheets	75 to 90 g/m <sup>2</sup> (20 to 24 lbs bond) • 5 sheets
	Envelope No. 10	105 x 241 mm (4.12 x 9.5 inches)	Not available in optional tray.	
	Envelope No. 9	98 x 225 mm (3.87 x 8.87 inches)		
	Envelope DL	110 x 220 mm (4.33 x 8.66 inches)		
	Envelope C5	162 x 229 mm (6.38 x 9.02 inches)		
	Envelope C6	114 x 162 mm (4.49 x 6.38 inches)		
Thick paper <sup>bc</sup>	Refer to the Plain paper section	Refer to the Plain paper section	91 to 105 g/m <sup>2</sup> (24 to 28 lbs bond) • 50 sheets of 105 g/m <sup>2</sup> (28 lbs bond)	91 to 105 g/m <sup>2</sup> (24 to 28 lbs bond) • 5 sheets
Thicker paper <sup>bc</sup>	Refer to the Plain paper section	Refer to the Plain paper section	164 to 220 g/m <sup>2</sup> (43 to 59 lbs bond) • 50 sheets of 220 g/m <sup>2</sup> (59 lbs bond) Not available in optional tray.	164 to 220 g/m <sup>2</sup> (43 to 59 lbs bond) • 5 sheets
Thin paper	Refer to the Plain paper section	Refer to the Plain paper section	60 to 70 g/m <sup>2</sup> (16 to 19 lbs bond) • 250 sheets of 70 g/m <sup>2</sup> (19 lbs bond)	60 to 70 g/m <sup>2</sup> (16 to 19 lbs bond) • 50 sheets
Cotton, Color, Pre-printed	Refer to the Plain paper section	Refer to the Plain paper section	75 to 90 g/m <sup>2</sup> (20 to 24 lbs bond) • 250 sheets of 75 g/m <sup>2</sup> (20 lbs bond) Not available in optional tray.	75 to 90 g/m <sup>2</sup> (20 to 24 lbs bond) • 50 sheets

# Specifications

Type	Size	Dimensions	Weight/Capacity <sup>a</sup>	
			Tray1/ Optional tray	Multi-purpose tray
<b>Recycled</b>	<b>Refer to the Plain paper section</b>	Refer to the Plain paper section	70 to 90 g/m <sup>2</sup> (19 to 24 lbs bond) • 250 sheets of 75 g/m <sup>2</sup> (20 lbs bond)	70 to 90 g/m <sup>2</sup> (19 to 24 lbs bond) • 50 sheets
<b>Labels<sup>d</sup></b>	<b>Letter, Legal, US Folio, A4, JIS B5, ISO B5, Executive, A5</b>	Refer to the Plain paper section	120 to 150 g/m <sup>2</sup> (32 to 40 lbs bond) • 50 sheets Not available in optional tray.	120 to 150 g/m <sup>2</sup> (32 to 40 lbs bond) • 5 sheets
<b>Card stock<sup>bc</sup></b>	<b>Letter, Legal, US Folio, A4, JIS B5, ISO B5, Executive, A5</b>	Refer to the Plain paper section	121 to 163 g/m <sup>2</sup> (32 to 43 lbs bond) • 20 sheets	121 to 163 g/m <sup>2</sup> (32 to 43 lbs bond) • 5 sheets
<b>Bond paper</b>	<b>Refer to the Plain paper section</b>	Refer to the Plain paper section	105 to 120 g/m <sup>2</sup> (28 to 32 lbs bond) • 50 sheets	105 to 120 g/m <sup>2</sup> (28 to 32 lbs bond) • 5 sheets
<b>Archive, Punched paper, Letterhead</b>	<b>Refer to the Plain paper section</b>	Refer to the Plain paper section	• 250 sheets	• 50 sheets

# Specifications

Type	Size	Dimensions	Weight/Capacity <sup>a</sup>	
			Tray1/ Optional tray	Multi-purpose tray
<b>Glossy Photo</b> <sup>b</sup>	Letter, A4, Postcard 4x6	Refer to the Plain paper section	111 to 130 g/m <sup>2</sup> (30 to 35 lbs bond) for tray1 • Tray1: 30 sheets Not available in optional tray.	111 to 130 g/m <sup>2</sup> (30 to 35 lbs bond) • 5 sheets
		Refer to the Plain paper section	131 to 175 g/m <sup>2</sup> (35 to 47 lbs bond) • Tray1: 30 sheets Not available in optional tray.	131 to 175 g/m <sup>2</sup> (35 to 47 lbs bond) • 5 sheets
		Refer to the Plain paper section	176 to 220 g/m <sup>2</sup> (47 to 59 lbs bond) • Tray1: 30 sheets Not available in optional tray.	176 to 220 g/m <sup>2</sup> (47 to 59 lbs bond) • 5 sheets
<b>Minimum size (custom)</b>		<ul style="list-style-type: none"> <li>• <b>Tray1:</b> 98 x 127 mm (3.86 x 5 inches)</li> <li>• <b>Optional tray:</b> 148.5 x 210 mm (5.85 x 8.27 inches)</li> <li>• <b>Multi-Purpose tray:</b> 76 x 127 mm (3 x 5 inches)</li> </ul>	<ul style="list-style-type: none"> <li>• 60 to 220 g/m<sup>2</sup> ( 16 to 59 lbs bond) for tray1</li> <li>• 60 to 163 g/m<sup>2</sup> ( 16 to 43 lbs bond) for optional tray.</li> </ul>	60 to 220 g/m <sup>2</sup> ( 16 to 59 lbs bond)
<b>Maximum size (custom)</b>	216 x 356 mm (8.5 x 14 inches)			

a. Maximum capacity may differ depending on media weight, thickness, and environmental conditions.

b. Post card 4 x 6 is supported for tray1 or Multi-purpose tray.

c. Index card (3x5) is supported for Multi-purpose tray.

d. The smoothness of the labels used in this machine is 100 to 250 (sheffield). This means the numeric level of smoothness.

# Specifications

## System requirements

### Microsoft® Windows®

Operating system	Requirement (recommended)		
	CPU	RAM	free HDD space
Windows® XP Service Pack 3	Intel® Pentium® III 933 MHz (Pentium IV 1 GHz)	128 MB (256 MB)	1.5 GB
Windows Server® 2003	Intel® Pentium® III 933 MHz (Pentium IV 1 GHz)	128 MB (512 MB)	1.25 GB to 2 GB
Windows Server® 2008	Intel® Pentium® IV 1 GHz (Pentium IV 2 GHz)	512 MB (2 GB)	10 GB
Windows Vista®	Intel® Pentium® IV 3 GHz	512 MB (1 GB)	15 GB
Windows® 7	Intel® Pentium® IV 1 GHz 32-bit or 64-bit processor or higher <ul style="list-style-type: none"><li>Support for DirectX® 9 graphics with 128 MB memory (to enable the Aero theme).</li><li>DVD-R/W Drive</li></ul>	1 GB (2 GB)	16 GB
Windows Server® 2008 R2	Intel® Pentium® IV 1.4 GHz (x64) processors (2 GHz or faster)	512 MB (2 GB)	10 GB
Windows® 8	Intel® Pentium® IV 1 GHz 32-bit or 64-bit processor or higher <ul style="list-style-type: none"><li>Support for DirectX® 9 graphics with 128 MB memory (to enable the Aero theme).</li><li>DVD-R/W Drive</li></ul>	2 GB (2 GB)	20 GB
Windows® 8.1			
Windows® 10			
Windows® Server 2016			
Windows Server® 2012	Intel® Pentium® IV 1.4 GHz (x64) processors (2 GHz or faster)	512 MB (2 GB)	32GB
Windows Server® 2012 R2			



- Internet Explorer 6.0 or higher is the minimum requirement for all Windows operating systems.
- Users who have administrator rights can install the software.
- **Windows Terminal Services** is compatible with your machine.

# Specifications

## Mac

Operating system	Requirements (Recommended)		
	CPU	RAM	Free HDD space
Mac OS X 10.6	<ul style="list-style-type: none"><li>Intel® processors</li></ul>	1 GB (2 GB)	1 GB
Mac OS X 10.7-10.11	<ul style="list-style-type: none"><li>Intel® processors</li></ul>	2 GB	4 GB

## Linux

Items	Requirements
<b>Operating system</b>	Red Hat Enterprise Linux 5, 6, 7 Fedora 13, 14, 15, 16, 17, 18, 19, 20, 21, 22 OpenSUSE 11.3, 11.4, 12.1, 12.2, 12.3, 13.1, 13.2 Ubuntu 10.04, 10.10, 11.04, 11.10, 12.04, 12.10, 13.04, 13.10, 14.04, 14.10, <a href="#">15.04</a> SUSE Linux Enterprise Desktop 11, 12 Debian 6, 7, 8 Mint 13, 14, 15, 16, 17
<b>CPU</b>	Pentium IV 2.4 GHz (Intel Core™ 2)
<b>RAM</b>	512 MB (1 GB)
<b>Free HDD space</b>	1 GB (2 GB)

# Specifications

## Unix

Items	Requirements
<b>Operating system</b>	Sun Solaris 9, 10, 11 (x86, SPARC) HP-UX 11.0, 11i v1, 11i v2, 11i v3 (PA-RISC, Itanium) IBM AIX 5.1, 5.2, 5.3, 5.4, 6.1, 7.1 (PowerPC)
<b>Free HDD space</b>	Up to 100 MB

# Specifications

## Network environment

You need to set up the network protocols on the machine to use it as your network machine. The following table shows the network environments supported by the machine.

Items	Specifications
<b>Network interface</b>	<ul style="list-style-type: none"><li>• Ethernet 10/100/1000 Base-TX Wired Lan</li><li>• 802.11b/g/n Wireless LAN<sup>a</sup></li></ul>
<b>Network operating system</b>	<ul style="list-style-type: none"><li>• Windows<sup>®</sup> XP Service Pack 3, Windows Server<sup>®</sup> 2003, Windows Vista<sup>®</sup>, Windows<sup>®</sup> 7/8, Windows Server<sup>®</sup> 2008 R2, Windows<sup>®</sup> 10, Windows<sup>®</sup> Sever 2016</li><li>• Various Linux OS</li><li>• Mac OS X 10.6 -10.11</li><li>• UNIX OS</li></ul>
<b>Network protocols</b>	<ul style="list-style-type: none"><li>• TCP/IPv4</li><li>• DHCP, BOOTP</li><li>• DNS, WINS, Bonjour, SLP, UPnP</li><li>• Standard TCP/IP Printing (RAW), LPR, IPP, WSD</li><li>• SNMPv 1/2/3, HTTP, IPSec</li><li>• TCP/IPv6 (DHCP, DNS, RAW, LPR, SNMPv 1/2/3, HTTP, IPSec)</li></ul>
<b>Wireless security<sup>a</sup></b>	<ul style="list-style-type: none"><li>• Authentication: Open System, Shared Key, WPA Personal, WPA2 Personal (PSK)</li><li>• Encryption: WEP64, WEP128, TKIP, AES</li></ul>

a. For C306xND and C306xFR, optional device.

# Regulatory information

This machine is designed for a normal work environment and certified with several regulatory statements.

## Laser safety statement

The printer is certified in the U.S. to conform to the requirements of DHHS 21 CFR, chapter 1 Subchapter J for Class I (1) laser products, and elsewhere is certified as a Class I laser product conforming to the requirements of IEC 60825-1 : 2007.

Class I laser products are not considered to be hazardous. The laser system and printer are designed so there is never any human access to laser radiation above a Class I level during normal operation, user maintenance or prescribed service condition.

## Warning

Never operate or service the printer with the protective cover removed from laser/scanner assembly. The reflected beam, although invisible, can damage your eyes.

When using this product, these basic safety precautions should always be followed to reduce risk of fire, electric shock, and injury to persons:



CAUTION - CLASS 3B, INVISIBLE LASER RADIATION WHEN OPEN. AVOID EXPOSURE TO THE BEAM.

ATTENTION - CLASSE 3B, RADIATION LASER INVISIBLE EN CAS D'OUVERTURE. EVITER L'EXPOSITION AU FAISCEAU.

GEFAHREN - KLASSE 3B: UNSICHTBARE LASERSTRAHLUNG WENN GEOFFNET. STRAHLENAUSSETZUNG VERMEIDEN.

ATTENZIONE - CLASSE 3B, RADIAZIONI LASER INVISIBILI CON IL DISPOSITIVO APERTO. EVITARE L'ESPOSIZIONE AL RAGGIO.

PRECAUCIÓN - RADIACIÓN LÁSER INVISIBLE DE CLASE 3B PRESENTE AL ABRIR. EVITE LA EXPOSICIÓN AL HAZ.

PERIGO - CLASSE 3B, RADIÇÃO LASER INVISÍVEL AO ABRIR. EVITE EXPOSIÇÃO DIRECTA AO FEIXE.

GEVAAR - KLASSE 3B. ONZICHTBARE LASERSTRALING INDIEN GEOPEND. VERMIJD BLOOTSTELLING AAN DE STRAAL.

ADVARSEL - KLASSE 3B. USYNLIG LASERSTRÅLING VED ÅBNING. UNDGÅ UDSÆTTELSE FOR STRÅLING.

ADVARSEL - KLASSE 3B. USYNLIG LASERSTRÅLING NÅR DEKSEL ÅPNES. UNNGÅ EKSPONERING FOR STRÅLEN.

VARNING - KLASSE 3B OSYNLIG LASERSTRÅLNING NÅR DENNA DEL ÄR ÖPPNAD. STRÅLEN ÄR FARLIG.

VAROITUS - LUOKAN 3B NÄKYMÄTTÖMÄLLE LASER-SÄTEILYÄ AVATTUNA. VÄLTÄ ALTISTUMISTA SÄTEELLE.

注意 - CLASS 3B。严禁打开, 以免被不可见激光辐射 泄漏灼伤

주의 - 열리면 등급 3B 비가시 레이저 방사선이 방출됩니다. 광선에 노출을 피하십시오.

注意 - CLASS 3B。嚴禁打開, 以免被不可見激光輻射洩漏灼傷



# Regulatory information

## Ozone safety



This product's ozone emission rate is under 0.1 ppm. Because ozone is heavier than air, keep the product in a place with good ventilation.

## Perchlorate warning

This Perchlorate warning applies only to primary CR (Manganese Dioxide) Lithium coin cells in the product sold or distributed ONLY in California USA.

Perchlorate Material - special handling may apply.

See [www.dtsc.ca.gov/hazardouswaste/perchlorate](http://www.dtsc.ca.gov/hazardouswaste/perchlorate). (U.S.A. only)

## Power saver



This printer contains advanced energy conservation technology that reduces power consumption when it is not in active use.

When the printer does not receive data for an extended period of time, power consumption is automatically lowered.

ENERGY STAR and the ENERGY STAR mark are registered U.S. marks.

For more information on the ENERGY STAR program see <http://www.energystar.gov>

For ENERGY STAR certified models, the ENERGY STAR label will be on your machine. Check if your machine is ENERGY STAR certified.

## Recycling



Recycle or dispose of the packaging material for this product in an environmentally responsible manner.

# Regulatory information

## Correct disposal of this product (Waste electrical & electronic equipment)

### (Applicable in countries with separate collection systems)



This marking on the product, accessories or literature indicates that the product and its electronic accessories (e.g. charger, headset, USB cable) should not be disposed of with other household waste at the end of their working life. To prevent possible harm to the environment or human health from uncontrolled waste disposal, please separate these items from other s of waste and recycle them responsibly to promote the sustainable reuse of material resources.

Household users should contact either the retailer where they purchased this product, or their local government office, for details of where and how they can take these items for environmentally safe recycling.

Business users should contact their supplier and check the terms and conditions of the purchase contract. This product and its electronic accessories should not be mixed with other commercial wastes for disposal.

## (The United States of America only)

Dispose unwanted electronics through an approved recycler. To find the nearest recycling location, go to our website: [www.samsung.com/recyclingdirect](http://www.samsung.com/recyclingdirect) Or call, (877) 278 - 0799

## EU REACH SVHC Declaration

For information on Samsung's environmental commitments and product specific regulatory obligations e.g. REACH visit: [samsung.com/uk/aboutsamsung/samsungelectronics/corporatecitizenship/data\\_corner.html](http://samsung.com/uk/aboutsamsung/samsungelectronics/corporatecitizenship/data_corner.html).

## State of California Proposition 65 Warning (USA Only)

The California Safe Drinking Water and Toxic Enforcement Act requires the Governor of California to publish a list of chemicals known to the state of California to cause cancer or reproductive toxicity and requires businesses to warn of exposure to such chemicals.

**WARNING:** This product contains chemicals known to the State of California to cause cancer and birth defects or other reproductive harm. This appliance and its accessories can cause low-level exposure to chemicals during operation, which can be reduced by operating the appliance in a well ventilated area, and low-level exposure to chemicals through other use or handling.

# Regulatory information

## Radio frequency emissions

### FCC information to the user

---

This device complies with Part 15 of the FCC Rules. Operation is subject to the following two conditions:

- This device may not cause harmful interference, and
- This device must accept any interference received, including interference that may cause undesired operation.

This equipment has been tested and found to comply with the limits for a Class A digital device, pursuant to Part 15 of the FCC Rules. These limits are designed to provide reasonable protection against harmful interference in a residential installation. This equipment generates, uses and can radiate radio frequency energy and, if not installed and used in accordance with the instructions, may cause harmful interference to radio communications. However, there is no guarantee that interference will not occur in a particular installation. If this equipment does cause harmful interference to radio or television reception, which can be determined by turning the equipment off and on, the user is encouraged to try to correct the interference by one or more of the following measures:

- Reorient or relocate the receiving antenna.
- Increase the separation between the equipment and receiver.
- Connect the equipment into an outlet on a circuit different from that to which the receiver is connected.
- Consult the dealer or experienced radio TV technician for help.



Change or modifications not expressly approved by the manufacturer responsible for compliance could void the user's authority to operate the equipment.

### Canadian radio interference regulations

---

This digital apparatus does not exceed the Class A limits for radio noise emissions from digital apparatus as set out in the interference-causing equipment standard entitled "Digital Apparatus", ICES-003 of the Industry and Science Canada.

Cet appareil numérique respecte les limites de bruits radioélectriques applicables aux appareils numériques de Classe A prescrites dans la norme sur le matériel brouilleur: "Appareils Numériques", ICES-003 édictée par l'Industrie et Sciences Canada.

# Regulatory information

## United States of America

### Federal Communications Commission (FCC)

#### Intentional emitter per FCC Part 15

Low power, Radio LAN devices (radio frequency (RF) wireless communication devices), operating in the 2.4 GHz/5 GHz Band, may be present (embedded) in your printer system. This section is only applicable if these devices are present. Refer to the system label to verify the presence of wireless devices.

Wireless devices that may be in your system are only qualified for use in the United States of America if an FCC ID number is on the system label.

The FCC has set a general guideline of 20 cm (8 inches) separation between the device and the body, for use of a wireless device near the body (this does not include extremities). This device should be used more than 20 cm (8 inches) from the body when wireless devices are on. The power output of the wireless device (or devices), which may be embedded in your printer, is well below the RF exposure limits as set by the FCC.

This transmitter must not be collocated or operation in conjunction with any other antenna or transmitter.

Operation of this device is subject to the following two conditions: (1) This device may not cause harmful interference, and (2) this device must accept any interference received, including interference that may cause undesired operation of the device.



Wireless devices are not user serviceable. Do not modify them in any way. Modification to a wireless device will void the authorization to use it. Contact manufacturer for service.

#### FCC Statement for Wireless LAN use:



While installing and operating this transmitter and antenna combination the radio frequency exposure limit of 1 mW/cm<sup>2</sup> may be exceeded at distances close to the antenna installed. Therefore, the user must maintain a minimum distance of 20 cm from the antenna at all times. This device cannot be collocated with another transmitter and transmitting antenna.

#### RFID (Radio Frequency Interface Device)

RFID operation is subject to the following two conditions:(1) this device may not cause interference, and (2) this device must accept any interference, including interference that may cause undesired operation of the device. (U.S.A., France, Taiwan only)

# Regulatory information

## China only

### 回收和再循环

为了保护环境，我公司已经为废弃的产品建立了回收和再循环系统。

我们会为您无偿提供回收同类废旧产品的服务。

当您要废弃您正在使用的产品时，请您及时与授权耗材更换中心取得联系，我们会及时为您提供服务。

Website: <http://www.samsung.com/cn/support/location/supportServiceLocation.do?page=SERVICE.LOCATION>

### 产品中有害物质的名称及含量

部件名称	有害物质					
	铅 (Pb)	汞 (Hg)	镉 (Cd)	六价铬 (Cr <sup>6+</sup> )	多溴联苯 (PBB)	多溴二苯醚 (PBDE)
塑料	○	○	○	○	○	○
金属 (机箱)	X	○	○	○	○	○
印刷电路部件 (PCA)	X	○	○	○	○	○
电缆 / 连接器	X	○	○	○	○	○
电源设备	X	○	○	○	○	○
电源线	X	○	○	○	○	○
机械部件	X	○	○	○	○	○
卡盒部件	X	○	○	○	○	○
定影部件	X	○	○	○	○	○
扫描仪部件 - CCD (如果有)	X	X	○	○	○	○
扫描仪部件 - 其它 (如果有)	X	○	○	○	○	○
印刷电路板部件 (PBA)	X	○	○	○	○	○
墨粉	○	○	○	○	○	○
滚筒	○	○	○	○	○	○

本表格依据 SJ/T 11364 的规定编制。

○：表示该有害物质在该部件所有均质材料中的含量均在 GB/T 26572 规定的限量要求以下。

X：表示该有害物质至少在该部件的某一均质材料中的含量超出 GB/T 26572 规定的限量要求。

### 警告

此为A级产品，在生活环境中，该产品可能会造成无线电干扰。  
在这种情况下，可能需要用户对其干扰采取切实可行的措施。

# Regulatory information

## Taiwan only

### 警告使用者：

此為甲類資訊技術設備，於居住環境中使用時，可能會造成射頻擾動，在此種情況下，使用者會被要求採取某此適當的對策。

### 警告

本電池如果更換不正確會有爆炸的危險  
請依製造商說明書處理用過之電池

### 低功率電波輻射性電機管理辦法

- 第十二條** 經型式認證合格之低功率射頻電機，非經許可，公司、商號或使用者均不得擅自變更頻率、加大功率或變更原設計之特性及功能。
- 第十四條** 低功率射頻電機之使用不得影響飛航安全及干擾合法通信；經發現有干擾現象時，應立即停用，並改善至無干擾時方得繼續使用。前項合法通信，指依電信法規定作業之無線電通信。低功率射頻電機須忍受合法通信或工業、科學及醫療用電波輻射性電機設備之干擾。

## Russia / Kazakhstan / Belarus only

# EAC

Изготовитель: «Самсунг Электроникс Ко., Лтд.»  
(Мэтан-донг) 129, Самсунг-ро, Енгтонг-гу, г. Сувон, Кёнги-до, Республика Корея  
Импортер: ООО «Самсунг Электроникс Рус Компани»  
Адрес: 125009, г. Москва, ул. Воздвиженка 10

Самсунг Электроникс Ко. Лтд  
(Мэтан-донг) 129, Самсунг-ро, Енгтонг-гу, Сувон қ., Кёнги-до, Корея Республикасы  
«САМСУНГ ЭЛЕКТРОНИКС КЗ ЭНД ЦЕНТРАЛ ЭЙЖА» ЖШС  
Заңды мекен-жайы: Қазақстан Республикасы, Алматы қ., Өл-Фараби даңғылы, 36, 3,4-қабаттар

## Germany only

Das Gerät ist nicht für die Benutzung am Bildschirmarbeitsplatz gemäß BildscharbV vorgesehen.

Das Gerät kann der Bildschirmarbeitsverordnung unterliegen und in diesem Zusammenhang Abweichungen von an Bildschirmarbeitsplätze zu stellenden Anforderungen (Zeichengröße auf Bildschirmgerät und Tastatur) aufweisen. Es ist daher für Tätigkeiten nicht geeignet, bei denen Beschäftigte das Gerät für einen nicht unwesentlichen Teil ihrer normalen Arbeit mit Bildschirmarbeit benutzen.

Bei Aufstellung des Gerätes darauf achten, dass Blendungen durch in der Anzeige spiegelnde Lichtquellen vermieden werden.

# Regulatory information

## Turkey only

- Bu ürünün ortalama yaşam süresi 7 yıl, garanti süresi 2 yıldır.

## Thailand only

This telecommunication equipment conforms to NTC technical requirement.

## Canada only

This product meets the applicable Industry Canada technical specifications. / Le présent matériel est conforme aux spécifications techniques applicables d'Industrie Canada.

The Ringer Equivalence Number (REN) is an indication of the maximum number of devices allowed to be connected to a telephone interface. The termination of an interface may consist of any combination of devices subject only to the requirement that the sum of the RENs of all the devices not exceed five. / L'indice d'équivalence de la sonnerie (IES) sert à indiquer le nombre maximal de terminaux qui peuvent être raccordés à une interface téléphonique. La terminaison d'une interface peut consister en une combinaison quelconque de dispositifs, à la seule condition que la somme d'indices d'équivalence de la sonnerie de tous les dispositifs n'excede pas cinq.

**Ringer Equivalence Number : 0.1/ Indice REN : 0.1**

## Fax Branding

The Telephone Consumer Protection Act of 1991 makes it unlawful for any person to use a computer or other electronic device to send any message via a telephone facsimile machine unless such message clearly contains in a margin at the top or bottom of each transmitted page or on the first page of the transmission the following information:

- 1 the date and time of transmission
- 2 identification of either business, business entity or individual sending the message; and
- 3 telephone number of either the sending machine, business, business entity or individual.

The Telephone Company may make changes in its communications facilities, equipment operations or procedures where such action is reasonably required in the operation of its business and is not inconsistent with the rules and regulations in FCC Part 68. If such changes can be reasonably expected to render any customer terminal equipment incompatible with telephone company communications facilities, or require modification or alteration of such terminal equipment, or otherwise materially affect its use or performance, the customer shall be given adequate notice in writing, to allow the customer an opportunity to maintain uninterrupted service.

# Regulatory information

## Ringer Equivalence Number

The Ringer Equivalence Number and FCC Registration Number for this machine may be found on the label located on the bottom or rear of the machine. In some instances you may need to provide these numbers to the telephone company.

The Ringer Equivalence Number (REN) is a measure of the electrical load placed on the telephone line, and is useful for determining whether you have “overloaded” the line. Installing several s of equipment on the same telephone line may result in problems making and receiving telephone calls, especially ringing when your line is called. The sum of all Ringer Equivalence Numbers of the equipment on your telephone line should be less than five in order to assure proper service from the telephone company. In some cases, a sum of five may not be usable on your line. If any of your telephone equipment is not operating properly, you should immediately remove it from your telephone line, as it may cause harm to the telephone network.

The equipment complies with Part 68 of the FCC rules and the requirements adopted by the ACTA. On the rear of this equipment is a label that contains, among other information, a product identifier in the format US:AAAEQ##TXXXX. If requested, this number must be provided to the telephone company.



FCC Regulations state that changes or modifications to this equipment not expressly approved by the manufacturer could void the user’s authority to operate this equipment. In the event that terminal equipment causes harm to the telephone network, the telephone company should notify the customer that service may be stopped. However, where prior notice is impractical, the company may temporarily cease service, providing that they:

- a promptly notify the customer.
- b give the customer an opportunity to correct the equipment problem.
- c inform the customer of the right to bring a complaint to the Federal Communication Commission pursuant to procedures set out in FCC Rules and Regulations Subpart E of Part 68.

## You should also know that:

- Your machine is not designed to be connected to a digital PBX system.
- If you intend to use a computer modem or fax modem on the same phone line as your machine, you may experience transmission and reception problems with all the equipment. It is recommended that no other equipment, except for a regular telephone, share the line with your machine.
- If your area experiences a high incidence of lightning or power surges, we recommend that you install surge protectors for both the power and the telephone lines. Surge protectors can be purchased from your dealer or telephone and electronic specialty stores.



# Regulatory information

- When programming emergency numbers and/or making test calls to emergency numbers, use a non-emergency number to advise the emergency service dispatcher of your intentions. The dispatcher will give you further instructions on how to actually test the emergency number.
- This machine may not be used on coin service or party lines.
- This machine provides magnetic coupling to hearing aids.

You may safely connect this equipment to the telephone network by means of a standard modular jack, USOC RJ-11C.

## Replacing the Fitted Plug (for UK Only)

### Important

The mains lead for this machine is fitted with a standard (BS 1363) 13 amp plug and has a 13 amp fuse. When you change or examine the fuse, you must re-fit the correct 13 amp fuse. You then need to replace the fuse cover. If you have lost the fuse cover, do not use the plug until you have another fuse cover.

Contact the people from you purchased the machine.

The 13 amp plug is the most widely used in the UK and should be suitable. However, some buildings (mainly old ones) do not have normal 13 amp plug sockets. You need to buy a suitable plug adaptor. Do not remove the moulded plug.



If you cut off the moulded plug, get rid of it straight away.

You cannot rewire the plug and you may receive an electric shock if you plug it into a socket.

### Important warning:

You must earth this machine.

The wires in the mains lead have the following color code:



- **Green and Yellow:** Earth
- **Blue:** Neutral
- **Brown:** Live

If the wires in the mains lead do not match the colors marked in your plug, do the following:

You must connect the green and yellow wire to the pin marked by the letter “E” or by the safety ‘Earth symbol’ or colored green and yellow or green.

You must connect the blue wire to the pin which is marked with the letter “N” or colored black.

You must connect the brown wire to the pin which is marked with the letter “L” or colored red.

You must have a 13 amp fuse in the plug, adaptor, or at the distribution board.

# Regulatory information

## Declaration of conformity (European countries)

### Approvals and Certifications



Hereby, Samsung Electronics, declares that this [C306x series] is in compliance with the essential requirements and other relevant provisions of R&TTE Directive 1999/5/EC.

The declaration of conformity may be consulted at [www.samsung.com](http://www.samsung.com), go to Support > Download center and enter your printer (MFP) name to browse the EuDoC.

**January 1, 1995:** Council Directive 2006/95/EC Approximation of the laws of the member states related to low voltage equipment.

**January 1, 1996:** Council Directive 2004/108/EC, approximation of the laws of the Member States related to electromagnetic compatibility.

**March 9, 1999:** Council Directive 1999/5/EC on radio equipment and telecommunications terminal equipment and the mutual recognition of their conformity. A full declaration, defining the relevant Directives and referenced standards can be obtained from your Samsung Electronics Co., Ltd. representative.

### EC Certification

Certification to 1999/5/EC Radio Equipment & Telecommunications Terminal Equipment Directive (FAX)

This Samsung product has been self-certified by Samsung for pan-European single terminal connection to the analogue public switched telephone network (PSTN) in accordance with Directive 1999/5/EC. The product has been designed to work with the national PSTNs and compatible PBXs of the European countries:

In the event of problems, you should contact the Euro QA Lab of Samsung Electronics Co., Ltd. in the first instance.

The product has been tested against TBR21. To assist in the use and application of terminal equipment which complies with this standard, the European Telecommunication Standards Institute (ETSI) has issued an advisory document (EG 201 121) which contains notes and additional requirements to ensure network compatibility of TBR21 terminals. The product has been designed against, and is fully compliant with, all of the relevant advisory notes contained in this document.

# Regulatory information

## European radio approval information (for products fitted with EU-approved radio devices)

Low power, Radio LAN type devices (radio frequency (RF) wireless communication devices), operating in the 2.4 GHz/5 GHz band, may be present (embedded) in your printer system which is intended for home or office use. This section is only applicable if these devices are present. Refer to the system label to verify the presence of wireless devices.



Wireless devices that may be in your system are only qualified for use in the European Union or associated areas if a CE mark with a Notified Body Registration Number and the Alert Symbol is on the system label.

The power output of the wireless device or devices that may be embedded in your printer is well below the RF exposure limits as set by the European Commission through the R&TTE directive.

### European states qualified under wireless approvals:

EU countries

### European states with restrictions on use:

EU

In France, this equipment may only be used indoors.

EEA/EFTA countries

No limitations at this time

## Regulatory compliance statements

### Wireless guidance

Low power, Radio LAN devices (radio frequency (RF) wireless communication devices), operating in the 2.4 GHz/5 GHz Band, may be present (embedded) in your printer system. The following section is a general overview of considerations while operating a wireless device.

Additional limitations, cautions, and concerns for specific countries are listed in the specific country sections (or country group sections). The wireless devices in your system are only qualified for use in the countries identified by the Radio Approval Marks on the system rating label. If the country you will be using the wireless device in, is not listed, contact your local Radio Approval agency for requirements. Wireless devices are closely regulated and use may not be allowed.

The power output of the wireless device or devices that may be embedded in your printer is well below the RF exposure limits as known at this time. Because the wireless devices (which may be embedded into your printer) emit less energy than is allowed in radio frequency safety standards and recommendations, manufacturer believes these devices are safe for use. Regardless of the power levels, care should be taken to minimize human contact during normal operation.

# Regulatory information

As a general guideline, a separation of 20 cm (8 inches) between the wireless device and the body, for use of a wireless device near the body (this does not include extremities) is typical. This device should be used more than 20 cm (8 inches) from the body when wireless devices are on and transmitting.

This transmitter must not be collocated or operation in conjunction with any other antenna or transmitter.

Some circumstances require restrictions on wireless devices. Examples of common restrictions are listed below:



Radio frequency wireless communication can interfere with equipment on commercial aircraft. Current aviation regulations require wireless devices to be turned off while traveling in an airplane. IEEE 802.11 (also known as wireless Ethernet) and Bluetooth communication devices are examples of devices that provide wireless communication.



In environments where the risk of interference to other devices or services is harmful or perceived as harmful, the option to use a wireless device may be restricted or eliminated. Airports, Hospitals, and Oxygen or flammable gas laden atmospheres are limited examples where use of wireless devices may be restricted or eliminated. When in environments where you are uncertain of the sanction to use wireless devices, ask the applicable authority for authorization prior to use or turning on the wireless device.



Every country has different restrictions on the use of wireless devices. Since your system is equipped with a wireless device, when traveling between countries with your system, check with the local Radio Approval authorities prior to any move or trip for any restrictions on the use of a wireless device in the destination country.



If your system came equipped with an internal embedded wireless device, do not operate the wireless device unless all covers and shields are in place and the system is fully assembled.



Wireless devices are not user serviceable. Do not modify them in any way. Modification to a wireless device will void the authorization to use it. Contact manufacturer for service.



Only use drivers approved for the country in which the device will be used. See the manufacturer System Restoration Kit, or contact manufacturer Technical Support for additional information.

# Copyright

© 2016 Samsung Electronics Co., Ltd. All rights reserved.

This user's guide is provided for information purposes only. All information included herein is subject to change without notice.

Samsung Electronics is not responsible for any direct or indirect damages, arising from or related to use of this user's guide.

- Samsung and the Samsung logo are trademarks of Samsung Electronics Co., Ltd.
- Microsoft, Windows, Windows Vista, Windows 7, Windows 8, Windows Server 2008 R2, Windows 10 and Windows Server 2016 are either registered trademarks or trademarks of Microsoft Corporation.
- Microsoft, Internet Explorer, Excel, Word, PowerPoint, and Outlook are either registered trademarks or trademarks of Microsoft Corporation in the United States and other countries.
- Google, Picasa, Google Cloud Print, Google Docs, Android and Gmail are either registered trademarks or trademarks of Google Inc.
- Mopria, the Mopria Logo and the Mopria Alliance logo are registered trademarks and service marks of Mopria Alliance, Inc. in the United States and other countries. Unauthorized use is strictly prohibited.
- iPad, iPhone, iPod touch, Mac and Mac OS are trademarks of Apple Inc., registered in the U.S and other countries.
- AirPrint and the AirPrint logo are trademarks of Apple Inc.
- All other brand or product names are trademarks of their respective companies or organizations.



QR code

The software included in this product contains open source software. You may obtain the complete corresponding source code for a period of three years after the last shipment of this product by sending an email to <mailto:oss.request@samsung.com>. It is also possible to obtain the complete corresponding source code in a physical medium such as a CD-ROM; a minimal charge will be required.

**The following URL [http://opensource.samsung.com/opensource/C3010\\_C3060\\_Series/seq/0](http://opensource.samsung.com/opensource/C3010_C3060_Series/seq/0) leads to the download page of the source code made available and open source license information as related to this product.** This offer is valid to anyone in receipt of this information.

# User Guide

---

Samsung Multifunction **ProXpress**

C306x series

## **ADVANCED**

This guide provides information about installation, advanced configuration, operation and troubleshooting on various OS environments.

Some features may not be available depending on models or countries.

## **BASIC**

This guide provides information concerning the installation, basic operation and troubleshooting on Windows.



## 1. Software Installation

<b>Installation for Mac</b>	158
<b>Reinstallation for Mac</b>	159
<b>Installation for Linux</b>	160
<b>Reinstallation for Linux</b>	161



## 2. Using a Network-Connected Machine

<b>Useful network programs</b>	163
<b>Wired network setup</b>	164
<b>Installing driver over the network</b>	169
<b>Wireless network setup</b>	176
<b>Using the NFC feature</b>	191
<b>Supported Mobile Apps</b>	200
<b>Mopria™</b>	201
<b>AirPrint</b>	203
<b>Samsung Cloud Print</b>	204
<b>PrinterOn</b>	207
<b>Google Cloud Print™</b>	209



## 3. Useful Setting Menus

<b>Before you begin reading a chapter</b>	212
<b>Print</b>	213
<b>Copy</b>	215
<b>Fax</b>	221
<b>Scan</b>	225
<b>System setup</b>	229
<b>Admin setup</b>	242
<b>Eco</b>	244
<b>Direct USB</b>	245
<b>Job Status</b>	246
<b>Document box</b>	247
<b>PrinterOn</b>	248



## 4. Special Features

<b>Altitude adjustment</b>	250
<b>Storing email address</b>	251
<b>Entering various characters</b>	253
<b>Setting up the fax address book</b>	255
<b>Registering authorized users</b>	259

<b>Printing features</b>	<b>260</b>
<b>Scan features</b>	<b>277</b>
<b>Fax features</b>	<b>286</b>
<b>Using shared folder features</b>	<b>293</b>

<b>Printing quality problems</b>	<b>327</b>
<b>Copying problems</b>	<b>335</b>
<b>Scanning problems</b>	<b>336</b>
<b>Faxing problems</b>	<b>338</b>
<b>Operating system problems</b>	<b>340</b>



## 5. Useful Management Tools

<b>Accessing management tools</b>	<b>295</b>
<b>SyncThru™ Web Service</b>	<b>296</b>
<b>Easy Capture Manager</b>	<b>302</b>
<b>Samsung AnyWeb Print</b>	<b>303</b>
<b>Easy Eco Driver</b>	<b>304</b>
<b>Using Samsung Easy Document Creator</b>	<b>305</b>
<b>Using Samsung Printer Center</b>	<b>306</b>
<b>Using Samsung Easy Printer Manager</b>	<b>309</b>
<b>Using Samsung Printer Status</b>	<b>312</b>
<b>Using Samsung Printer Experience</b>	<b>314</b>



## 6. Troubleshooting

<b>Paper feeding problems</b>	<b>321</b>
<b>Power and cable connecting problems</b>	<b>322</b>
<b>Printing problems</b>	<b>323</b>





# 1. Software Installation

This chapter provides instructions for installing essential and helpful software for use in an environment where the machine is connected via a cable. A locally connected machine is a machine directly attached to your computer using the cable. If your machine is attached to a network, skip the following steps below and go on to installing a network connected machine's driver (see "Installing driver over the network" on page 169).

- **Installation for Mac** **158**
- **Reinstallation for Mac** **159**
- **Installation for Linux** **160**
- **Reinstallation for Linux** **161**



- If you are a Windows OS user, refer to the Basic Guide for installing the machine's driver (see "Installing the driver locally" on page 24).
- Only use a USB cable no longer than 3 meter (118 inches).

# Installation for Mac

- 1 Make sure that the machine is connected to your computer and powered on.
- 2 Download the software from the Samsung website then unpack and install it (<http://www.samsung.com> > find your product > Support or Downloads).
- 3 Turn on the machine.
- 4 Double-click the **Install Software** icon.
- 5 Read the license agreement and check installation agreement button.
- 6 Click **Next** and then follow the instructions in the installation window.



To install the fax driver:

- a Open the **Applications** folder > **Samsung** > **Fax Queue Creator**.
- b Your machine appears on the **Printer List**.
- c Select machine to use and click **Create** button.

# Reinstallation for Mac

If the printer driver does not work properly, uninstall the driver and reinstall it.

- 1 Open the **Applications** folder > **Samsung** > **Printer Software Uninstaller**.
- 2 To uninstall printer software, click **Continue**.
- 3 Check the program you want to delete and click **Uninstall**.
- 4 Enter the password and click **OK**.
- 5 After the uninstallation is finished, click **Close**.



If a machine has already been added, delete it from the **Print Setup Utility** or **Print & Fax**.

# Installation for Linux

You need to download Linux software packages from the Samsung website to install the printer software (<http://www.samsung.com> > find your product > Support or Downloads).

## Installing the Unified Linux Driver



You must log in as a super user (root) to install the machine software. If you are not a super user, ask your system administrator.

- 1 Make sure that the machine is connected to your computer and powered on.
- 2 Copy **Unified Linux Driver** package to your system.
- 3 Open Terminal program and go to the folder that you copied the package to.
- 4 Extract the package.
- 5 Move to **uld** folder.
- 6 Execute **./install.sh** command (If you're not logged in as root, execute the command with **sudo** as **sudo ./install.sh**).
- 7 Proceed with installation.

- 8 When installation finished, launch printing utility (Go to **System** > **Administration** > **Printing** or execute **"system-config-printer"** command in Terminal program).
- 9 Click **Add** button.
- 10 Select your printer.
- 11 Click **Forward** button and add it to your system.

# Reinstallation for Linux

If the printer driver does not work properly, uninstall the driver and reinstall it.

- 1 Open **Terminal** program.
- 2 Move to **uld** folder extracted from **Unified Linux Driver** package.
- 3 Execute "**./uninstall.sh**" command (If you're not logged in as root, execute the command with "**sudo**" as "**sudo ./uninstall.sh**").
- 4 Proceed with uninstallation.



## 2. Using a Network-Connected Machine

This chapter gives you step-by-step instructions for setting up a network connected machine and software.

- **Useful network programs** 163
- **Wired network setup** 164
- **Installing driver over the network** 169
- **Wireless network setup** 176
- **Using the NFC feature** 191
- **Supported Mobile Apps** 200
- **Mopria™** 201
- **AirPrint** 203
- **Samsung Cloud Print** 204
- **PrinterOn** 207
- **Google Cloud Print™** 209



Supported optional devices and features may differ according to your model (see "Features by model" on page 7).

# Useful network programs

There are several programs available to setup the network settings easily in a network environment. For the network administrator especially, managing several machines on the network is possible.



- Before using the programs below, set the IP address first.
- Some features and optional goods may not be available depending on model or country (see "Features by model" on page 7).

## SyncThru™ Web Service

The web server embedded on your network machine allows you to do the following tasks (see "SyncThru™ Web Service" on page 296).

- Check the supplies information and status.
- Customize machine settings.
- Set the email notification option. When you set this option, the machine status (toner cartridge shortage or machine error) will be sent to a certain person's email automatically.
- Configure the network parameters necessary for the machine to connect to various network environments.

## SetIP wired network setup

This utility program allows you to select a network interface and manually configure the IP addresses for use with the TCP/IP protocol.

- See "Setting IP address" on page 164.



The machine that does not support the network port, it will not be able to use this feature (see "Rear view" on page 20).



# Wired network setup

## Printing a network configuration report

You can print **Network Configuration Report** from the machine's control panel that will show the current machine's network settings. This will help you to set up a network.



Accessing menus may differ from model to model (see "Accessing the menu" on page 28).

- **The machine has the display screen:** Press the  (**Menu**) button on the control panel and select **Network > Network Configuration**.
- **The machine has the touch screen:** Press  (**Setup**) from the **Main screen > Machine Setup > Next > Reports > Network Configuration**.

Using this **Network Configuration Report**, you can find your machine's MAC address and IP address.

For example:

- MAC Address: 30:CD:A7:41:A2:78
- IP Address: 169.254.192.192

## Setting IP address

When you connect your machine to a network, you must first configure the TCP/IP settings for the machine. The settings shown below are the basic settings required for using your machine as a network machine. You can set TCP/IP, DNS server, TCP/IPv6, Ethernet, and IP address allocation methods.

First, you have to set up an IP address for network printing and managements. In most cases a new IP address will be automatically assigned by a DHCP (Dynamic Host Configuration Protocol) server located on the network.

## IPv4 configuration



- You can also set the TCP/IPv4 from control panel.
- TCP/IPv6 is not supported by this program.

## IPv4 configuration using SetIP (Windows)

Before using the SetIP program, disable the computer firewall from **Control Panel > Security Center > Windows Firewall**.



The following instructions may differ for your model.



# Wired network setup

- 1 Download the software from the Samsung website then unpack and install it: (<http://www.samsung.com> > find your product > Support or Downloads).
- 2 Follow the instructions in the installation window.
- 3 Connect your machine to the network with a network cable.
- 4 Turn on the machine.
- 5 From the Windows **Start** menu, select **All Programs > Samsung Printers > SetIP**.
- 6 Click the  icon (third from left) in the SetIP window to open the TCP/IP configuration window.
- 7 Enter the machine's new information into the configuration window. In a corporate intranet, you may need to have this information assigned by a network manager before proceeding.



Find the machine's MAC address from the **Network Configuration Report** (see "Printing a network configuration report" on page 164) and enter it without the colons. For example, 30:CD:A7:1F:E3:27 becomes 30CDA71FE327.

- 8 Click **Apply**, and then click **OK**. The machine will automatically print the **Network Configuration Report**. Confirm that all the settings are correct.

## IPv4 configuration using SetIP (Mac)

Before using the SetIP program, disable the computer firewall from **System Preferences > Security** (or **Security & Privacy**) > **Firewall**.

- 1 Download the software from the Samsung website then unpack and install it: (<http://www.samsung.com> > find your product > Support or Downloads).
- 2 Turn on the machine.
- 3 Run downloaded **SetIP** application.
- 4 Click the  icon (third from left) in the SetIP window to open the TCP/IP configuration window.
- 5 Enter the machine's new information into the configuration window. In a corporate intranet, you may need to have this information assigned by a network manager before proceeding.



Find the machine's MAC address from the **Network Configuration Report** (see "Printing a network configuration report" on page 164) and enter it without the colons. For example, 30:CD:A7:1F:E3:27 becomes 30CDA71FE327.

- 6 Click **Apply**, and then click **OK**. The machine will automatically print the **Network Configuration Report**. Confirm that all the settings are correct.

# Wired network setup

## IPv4 configuration using SetIP (Linux)

Before using the SetIP program, disable the computer firewall from **System Preferences** or **Administrator**.

 The following instructions may vary from your model or operating systems.

- 1 Download the SetIP program from the Samsung web site and extract it.
- 2 Double-click the **SetIPApplet.html** file in **cdroot/Linux/noarch/at\_opt/share/utils** folder.
- 3 Click to open the TCP/IP configuration window.
- 4 Enter the machine's new information into the configuration window. In a corporate intranet, you may need to have this information assigned by a network manager before proceeding.

 Find the machine's MAC address from the **Network Configuration Report** (see "Printing a network configuration report" on page 164) and enter it without the colons. For example, 30:CD:A7:29:51:A8 becomes 30CDA72951A8.

- 5 The machine will automatically print the **Network Configuration Report**.

## IPv6 configuration



IPv6 is supported properly only in Windows Vista or higher.

### Activating IPv6 from the control panel

- 1 Select  (**Menu**) > **Network** > **TCP/IP (IPv6)** > **IPv6 Activate** on the control panel.

OR

For the model with a touch screen, press  (**Setup**) > **Machine Setup** > **Next** > **Network Setup** > **TCP/IP (IPv6)** > **IPv6 Protocol** on the touch screen.

- 2 Select **On** and press **OK**.

For the model with a touch screen, select **On** and press **Yes** when the confirmation windows appears. Press  (Back) to save the selection.

- 3 Turn the machine off and turn it on again.



When you install the printer driver, do not configure both IPv4 and IPv6. We recommend to configure either IPv4 or IPv6.

# Wired network setup

## DHCPv6 address configuration from the control panel

If you have a DHCPv6 server on your network, you can set one of the following options for default dynamic host configuration.

- 1 Select  (**Menu**) > **Network** > **TCP/IP (IPv6)** > **DHCPv6 Config** on the control panel.

OR

For the model with a touch screen, press  (**Setup**) > **Machine Setup** > **Next** > **Network Setup** > **TCP/IP (IPv6)** > **DHCPv6 Config** on the touch screen.

- 2 Select the required value you want.
  - **Always Use:** Always use DHCPv6 regardless of router request.
  - **Never Use:** Never use DHCPv6 regardless of router request.
  - **Router:** Use DHCPv6 only when requested by a router.

## Activating from the SyncThru™ Web Service

- 1 Check whether the machine is connected to the network.
- 2 Start a web browser such as Internet Explorer, Safari, or Firefox and enter your machine's new IP address in the browser window.

For example,



- 3 Click **Login** in the upper right of the SyncThru™ Web Service website.
- 4 Type in the **ID** and **Password**, then click **Login**. If it's your first time logging into SyncThru™ Web Service, type in the below default ID and password. We recommend you to change the default password for security reasons.
  - **ID: admin**
  - **Password: sec00000**
- 5 When the **SyncThru™ Web Service** window opens, move the mouse cursor over the **Settings** of the top menu bar and then click **Network Settings**.
- 6 Click **TCP/IPv6** on the left pane of the website.
- 7 Check the **IPv6 Protocol** check box to activate IPv6.
- 8 Click the **Apply** button.
- 9 Turn the machine off and turn it on again.



- You can also set the DHCPv6.
- To manually set the IPv6 address:  
Check the **Manual Address** check box. Then, the **Address/Prefix** text box is activated. Enter the rest of the address (e.g.,:3FFE:10:88:194::AAAA. "A" is the hexadecimal 0 through 9, A through F).

# Wired network setup

## IPv6 address configuration from the SyncThru™ Web Service

- 1 Check whether the machine is connected to the network.
- 2 Start a web browser such as Internet Explorer, Safari, or Firefox and enter your machine's new IP address in the browser window.

For example,



http://192.168.1.133/

- 3 Click **Login** in the upper right of the SyncThru™ Web Service website.
- 4 Type in the **ID** and **Password**, then click **Login**. If it's your first time logging into SyncThru™ Web Service, type in the below default ID and password. We recommend you to change the default password for security reasons.
  - **ID: admin**
  - **Password: sec00000**
- 5 When the **SyncThru™ Web Service** window opens, move the mouse cursor over the **Settings** of the top menu bar and then click **Network Settings**.
- 6 Click **TCP/IPv6** on the left pane of the website.

- 7 Select one of the IPv6 addresses from **Address Type** (see "Printing a network configuration report" on page 164).
  - **Link-Local Address:** Self-configured local IPv6 address (Address starts with FE80).
  - **Stateless Address:** Automatically configured IPv6 address by a network router.
  - **Stateful Address:** IPv6 address configured by a DHCPv6 server.
  - **Manual Address:** Manually configured IPv6 address by a user.
  - **Default Gateway:** Default gateway configured IPv6 address by a network router.
- 8 Enter the IPv6 addresses (e.g.,: http://[FE80::215:99FF:FE66:7701]).



Address must be enclosed in '[' ]' brackets.

# Installing driver over the network

You must install the printer driver software for printing. The software includes drivers, applications, and other support programs.

Make sure that the network setup for your machine is completed. All applications should be closed on your computer before beginning installation.

## Windows

- 1 Make sure that the machine is connected to the network and powered on. Also, your machine's IP address should have been set.
- 2 Insert the supplied software CD into your CD-ROM drive.



If the installation window does not appear, click **Start** > **All programs** > **Accessories** > **Run**.

X:\Setup.exe replacing "X" with the letter, which represents your CD-ROM drive and click **OK**.

- For Windows 8

If the installation window does not appear, from **Charms**, select **Search** > **Apps** and search for **Run**. Type in X:\Setup.exe, replacing "X" with the letter that represents your CD-ROM drive and click **OK**.

If "Tap to choose what happens with this disc." pop-up window appears, click the window and select **Run Setup.exe**.

- For Windows 10 / Windows Server 2016

If the installation window does not appear, type in X:\Setup.exe in **Search** input area from task bar, replacing "X" with the letter that represents your CD-ROM drive and press the Enter key.

- 3 Review and accept the installation agreements in the installation window. Then, click **Next**.
- 4 Select **Network** on the **Printer Connection Type** screen. Then, click **Next**.
- 5 Follow the instructions in the installation window.

# Installing driver over the network

## From the Windows 8 Start Screen



- The V4 driver is automatically downloaded from the Windows Update if your computer is connected to the Internet. Or, you can manually download the V4 driver from Samsung website, [www.samsung.com](http://www.samsung.com) > find your product > Support or downloads.
- You can download **Samsung Printer Experience** app from the Windows Store. You need have a Microsoft account to use the Windows Store.
  - a From **Charms**, select **Search**.
  - b Click **Store**.
  - c Search and click **Samsung Printer Experience**.
  - d Click **Install**.
- If you install the driver using the supplied software CD, V4 driver is not installed. If you want to use the V4 driver in the **Desktop** screen, you can download from the Samsung website, [www.samsung.com](http://www.samsung.com) > find your product > Support or downloads.
- If you want to install Samsung's printer management tools, you need to install them using the supplied software CD.

- 1 Make sure that the machine is connected to the network and powered on. Also, your machine's IP address should have been set.
- 2 From **Charms**, select **Settings** > **Change PC settings** > **Devices**.



For Windows 10 / Windows Server 2016

From task bar, type in **Devices and Printers** in **Search** input area. Press the Enter key.

OR

From the **Start** () icon, select **Settings** > **Devices** > **Devices and Printers**.

- 3 Click **Add a device**.  
Discovered machines will be shown on the screen.
- 4 Click the model name or host name you wish to use.



You can print a Network Configuration Report from the machine's control panel that will show the current machine's host name.

- 5 The driver is automatically installed from the **Windows Update**.

## Silent installation Mode

Silent installation mode is an installation method that does not require any user intervention. Once you start the installation, the machine driver and software are automatically installed on your computer. You can start the silent installation by typing **/s** or **/S** in the command window.

# Installing driver over the network

## Command-line Parameters

Following table shows commands that can be used in the command window.



Following command-line are effective and operated when command is used with **/s** or **/S**. But **/h**, **/H** or **/?** are exceptional commands that can be operated solely.

Command- line	Definition	Description
/s or /S	Starts silent installation.	Installs machine drivers without prompting any UIs or user intervention.

Command- line	Definition	Description
/p"<port name>" or /P"<port name>"	 Network Port will be created by use of Standard TCP/IP Port monitor. For local port, this port must exist on system before being specified by command.	Printer port name can be specified as IP address, hostname, USB local port name, IEEE1284 port name or network path. For example: <ul style="list-style-type: none"><li>• /p"xxx.xxx.xxx.xxx" in where, "xxx.xxx.xxx.xxx" means IP address for network printer. /p"USB001", /P"LPT1:", /p"hostname"</li><li>• /p"\\computer_name\shared_printer" or "\\xxx.xxx.xxx.xxx\shared_printer" in where, "\\computer_name\shared_printer" or "\\xxx.xxx.xxx.xxx\shared_printer" means the network path to the printer by entering two slashes, the computer name or local IP address of the PC sharing the printer, and then the share name of the printer.</li></ul>

# Installing driver over the network

Command- line	Definition	Description
/a"<dest_path>" or /A"<dest_path>"	Specifies destination path for installation.   The destination path should be a fully qualified path.	Since machine drivers should be installed on the OS specific location, this command applies to only application software.
/n"<Printer name>" or /N"<Printer name>"	Specifies printer name. Printer instance shall be created as specified printer name.	With this parameter, you can add printer instances as your wishes.
/nd or /ND	Commands not to set the installed driver as a default machine driver.	It indicates installed machine driver will not be the default machine driver on your system if there are one or more printer drivers installed. If there is no installed machine driver on your system, then this option won't be applied because Windows OS will set installed printer driver as a default machine driver.

Command- line	Definition	Description
/x or /X	Uses existing machine driver files to create printer instance if it is already installed.	This command provides a way to install a printer instance that uses installed printer driver files without installing an additional driver.
/up"<printer name>" or /UP"<printer name>"	Removes only specified printer instance and not the driver files.	This command provides a way to remove only specified printer instance from your system without effecting other printer drivers. It will not remove printer driver files from your system.
/d or /D	Uninstalls all device drivers and applications from your system.	This command will remove all installed device drivers and application software from your system.
/V"<share name>" or /V"<share name>"	Shares installed machine and add other available platform drivers for Point & Print.	It will install all supported Windows OS platform's machine drivers to system and share it with specified <share name> for point and print.
/o or /O	Opens <b>Printers and Faxes</b> folder after installation.	This command will open <b>Printers and Faxes</b> folder after the silent installation.
/h, /H or /?	Shows Command-line Usage.	



# Installing driver over the network

## Mac

- 1 Make sure that the machine is connected to your computer and powered on.
- 2 Download the software from the Samsung website then unpack and install it: (<http://www.samsung.com> > find your product > Support or Downloads).
- 3 Turn on the machine.
- 4 Double-click the **Install Software** icon.
- 5 Read the license agreement and check installation agreement button.
- 6 Click **Next**.
- 7 Select **Network** on the **Printer Connection Type**.
- 8 Click **Next**.
- 9 Follow the instructions in the installation window.

## Linux

You need to download Linux software packages from the Samsung website to install the printer software (<http://www.samsung.com> > find your product > Support or Downloads).

- 1 Make sure that the machine is connected to your network and powered on. Also, your machine's IP address should have been set.
- 2 Copy **Unified Linux Driver** package to your system.
- 3 Open Terminal program and go to the folder that you copied the package to.
- 4 Extract the package.
- 5 Move to **uld** folder.
- 6 Execute "**./install.sh**" command (If you are not logged in as root, execute the command with "**sudo**" as "**sudo ./install.sh**").
- 7 Proceed with installation.
- 8 When installation finished, launch **Printing** utility (Go to **System > Administration > Printing** or execute "**system-config-printer**" command in Terminal program).
- 9 Click **Add** button.
- 10 Select **AppSocket/HP JetDirect** and enter your machine's IP address.
- 11 Click **Forward** button and add it to your system.

# Installing driver over the network

## UNIX



- Make sure your machine supports the UNIX operating system before installing the UNIX printer driver (see "System requirements" on page 136).
- The commands are marked with "", when typing the commands, do not type "".
- Some features and optional goods may not be available depending on model or country (see "System requirements" on page 136).

To use the UNIX printer driver, you have to install the UNIX printer driver package first, then setup the printer. You can download the UNIX printer driver package from the Samsung website (<http://www.samsung.com> > find your product > Support or Downloads).

## Installing the UNIX printer driver package

The installation procedure is common for all variants of UNIX OS mentioned.

- 1 From the Samsung website, download and unpack the UNIX Printer Driver package to your computer.
- 2 Acquire root privileges.  
"su -"

- 3 Copy the appropriate driver archive to the target UNIX computer.



See administration guide of your UNIX OS for details.

- 4 Unpack the UNIX printer driver package.  
For example, on IBM AIX, use the following commands.  
"gzip -d < enter the package name | tar xf -"

- 5 the unpacked directory.

- 6 Run the install script.

"/install -i"

**install** is the installer script file which is used to install or uninstall the UNIX Printer Driver package.

Use "**chmod 755 install**" command to give the permission to the installer script.

- 7 Execute the ". /install -c" command to verify installation results.

- 8 Run "**installprinter**" from the command line. This will bring up the **Add Printer Wizard** window. Setup the printer in this window referring to the following procedures.

# Installing driver over the network



On some UNIX OS, for example on Solaris 10, just added printers may not be enabled and/or may not accept jobs. In this case run the following two commands on the root terminal:

```
"accept <printer_name>"
```

```
"enable <printer_name>"
```

## Uninstalling the printer driver package



The utility should be used to delete the printer installed in the system.

- a** Run "**uninstallprinter**" command from the terminal.  
It will open the **Uninstall Printer Wizard**.  
The installed printers are listed in the drop-down list.
- b** Select the printer to be deleted.
- c** Click **Delete** to delete the printer from the system.
- d** Execute the "**./install -d**" command to uninstall the whole package.
- e** To verify removal results, execute the "**./install -c**" command.

To re-install it, use the command "**./install -i**" to reinstall the binaries.

## Setting up the printer

To add the printer to your UNIX system, run 'installprinter' from the command line. This will bring up the Add Printer Wizard window. Setup the printer in this window according to the following steps:

- 1** Type the name of the printer.
- 2** Select the appropriate printer model from the model list.
- 3** Enter any description corresponding to the type of the printer in the **Type** field. This is optional.
- 4** Specify any printer description in the **Description** field. This is optional.
- 5** Specify the printer location in the **Location** field.
- 6** Type the IP address or DNS name of the printer in the **Device** textbox for network-connected printers. On IBM AIX with **jetdirect Queue type**, only the DNS name is possible-numeric IP address is not allowed.
- 7** **Queue type** shows the connection as **lpd** or **jetdirect** in the corresponding list box. Additionally, **usb** type is available on Sun Solaris OS.
- 8** Select **Copies** to set the number of copies.
- 9** Check the **Collate** option to receive copies already sorted.
- 10** Check the **Reverse Order** option to receive copies in the reverse order.
- 11** Check the **Make Default** option to set this printer as default.
- 12** Click **OK** to add the printer.

# Wireless network setup



- For C306xND and C306xFR, check the option lists and contact the purchasing point to order (see "Available accessories" on page 83). After installing the Wireless/NFC kit (Optional), set the machine to use this feature.
- Make sure your machine supports wireless networking. Wireless networking may not be available depending on the model (see "Features by model" on page 7).

Wireless networks require higher security, so when an access point is first set up, a network name (SSID), the type of security used, and a Network Password are created for the network. Ask your network administrator about this information before proceeding with the machine installation.

## Introducing wireless set up methods

You can set wireless settings either from the machine or the computer. Choose the setting method from the below table.



- Some wireless network installation types may not be available depending on the model or country.
- It is strongly recommended that you set the password on Access Points. If you do not set the password on Access Points, they might be exposed to illegal access from unknown machines including PCs, smart phones and printers. Refer to the Access Point user' guide for password settings.

Set up method	Connecting method	Description & Reference
<b>With Access Point</b>	<b>From the computer</b>	See "Setting up via USB cable" on page 180 for Window.
		See "Setting up via USB cable" on page 182 for Mac.
		See "Using a network cable" on page 184.
	<b>From the machine's control panel</b>	See "Using the WPS menu" on page 177. See "Using the Wi-Fi Networks" on page 179.
<b>Wi-Fi Direct setup</b>		See "Setting the Wi-Fi Direct for mobile printing" on page 186.

# Wireless network setup

## Using the WPS menu

If your machine and access point (or wireless router) support Wi-Fi Protected Setup™ (WPS), then you can easily configure the wireless network settings through the **WPS Settings** menu without the need for a computer.



- If you want to use the wireless network using the infrastructure mode, make sure that the network cable is disconnected from the machine. Using the **WPS(PBC)** or entering the PIN from the computer to connect to the access point (or wireless router) varies depending on the access point (or wireless router) you are using. Refer to the user's guide of the access point (or wireless router) you are using.
- When using the WPS to set the wireless network, security settings may change. To prevent this, lock the WPS option for the current wireless security settings. The option name may differ depending on the access point (or wireless router) you are using.

## Items to prepare

- Check if the access point (or wireless router) supports Wi-Fi Protected Setup™ (WPS).
- Check if your machine supports Wi-Fi Protected Setup™ (WPS).
- Networked computer (PIN mode only)

## Choosing your type

There are two methods available to connect your machine to a wireless network.

- The **Push Button Configuration (PBC)** method allows you to connect your machine to a wireless network by pressing both the **WPS Settings** menu on the control panel of your machine and the WPS (PBC) button on a Wi-Fi Protected Setup™ WPS-enabled access point (or wireless router) respectively.
- The **Personal Identification Number (PIN)** method helps you connect your machine to a wireless network by entering the supplied PIN information on a Wi-Fi Protected Setup™ WPS-enabled access point (or wireless router).

# Wireless network setup

## Connecting WPS

Factory default in your machine is **PBC** mode, which is recommended for a typical wireless network environment.



If the machine is connected to a wired network, then you cannot connect to it using the WPS feature. If a network cable is plugged into the network port, remove it from the network port.

## Connecting in PBC mode

- 1 Select  (**Menu**) > **Network** > **Wi-Fi** > **WPS** on the control panel.  
OR

For models that have the touch screen on the control panel, press  (**Setup**) > **Machine Setup** > **Next** > **Network Setup** > **Wi-Fi** > **WPS**.

- 2 Press **Connect via PBC**.
- 3 Press **OK** or **Yes** when the confirmation window appears.  
Information window appears showing 2 minutes connection processing time.

- 4 Press the **WPS (PBC)** button on the access point (or wireless router).  
The messages are displayed on the display screen in the order below:
  - a **Connecting:** The machine is connecting to the access point (or wireless router).
  - b **Connected:** When the machine is successfully connected to the wireless network, the WPS LED light stays on.
  - c **Network Name(SSID):** After completing the wireless network connection process, the AP's SSID information appears on the display.
- 5 Insert the supplied software CD into your CD-ROM drive, and follow the instructions in the window to set up the wireless network.

## Connecting in PIN mode

- 1 Select  (**Menu**) > **Network** > **Wi-Fi** > **WPS** on the control panel.  
OR

For models that have the touch screen on the control panel, press  (**Setup**) > **Machine Setup** > **Next** > **Network Setup** > **Wi-Fi** > **WPS**.

- 2 Press **Connect via PIN**.
- 3 Press **OK** or **Yes** when the confirmation window appears.

# Wireless network setup

4 The eight-digit PIN appears on the display.

You need to enter the eight-digit PIN within two minutes on the computer that is connected to the access point (or wireless router).

The messages are displayed on the display screen in the order below:

- a **Connecting:** The machine is connecting to the wireless network.
- b **Connected:** When the machine is successfully connected to the wireless network, the WPS LED light stays on.
- c **Network Name(SSID):** After completing the wireless network connection process, the AP's SSID information is displayed on the LCD display.

5 Insert the supplied software CD into your CD-ROM drive, and follow the instructions in the window to set up the wireless network.

## Using the Wi-Fi Networks

Before starting, you will need to know the network name (SSID) of your wireless network and the network key if it is encrypted. This information was set when the access point (or wireless router) was installed. If you do not know about your wireless environment, please ask the person who set up your network.

1 Select the  (**Menu**) > **Network** > **Wi-Fi** > **Wi-Fi Settings** button on the control panel.

OR

For models that have the touch screen on the control panel, press  (**Setup**) > **Machine Setup** > **Next** > **Network Setup** > **Wi-Fi** > **Wi-Fi Settings** on the touch screen.

2 Select the setup method you want.

- **Search List** (recommended): In this mode, the setup is automatic. The machine will display a list of available networks from which to choose. After a network is chosen then printer will prompt for the corresponding security key.
- **Custom:** In this mode, users can give or edit manually their own SSID, or choose the security option in detail.

3 Follow the instructions to set up the wireless network.

# Wireless network setup

## Setup using Windows



Shortcut to the **Samsung Easy Wireless Setup** program without the CD: If you have installed the printer driver once, you can access the **Samsung Easy Wireless Setup** program without the CD.

## Setting up via USB cable

### Items to prepare

- Access point
- Network-connected computer
- Software CD that was provided with your machine
- A machine installed with a wireless network interface
- USB cable

### Creating the infrastructure network

- 1 Check whether the USB cable is connected to the machine.
- 2 Turn on your computer, access point, and machine.

- 3 Insert the supplied software CD into your CD-ROM drive.

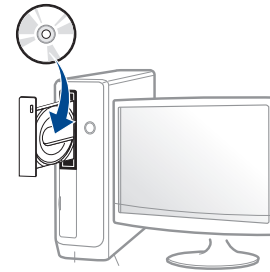

If the installation window does not appear, click **Start > All programs > Accessories > Run**.

X:\Setup.exe replacing "X" with the letter, which represents your CD-ROM drive and click **OK**.

- For Windows 8,

If the installation window does not appear, from **Charms**, select **Search > Apps** and search for **Run**. Type in X:\Setup.exe, replacing "X" with the letter that represents your CD-ROM drive and click **OK**.

If "**Tap to choose what happens with this disc.**" pop-up window appears, click the window and select **Run Setup.exe**.

- For Windows 10 / Windows Server 2016

If the installation window does not appear, type in X:\Setup.exe in **Search** input area from task bar, replacing "X" with the letter that represents your CD-ROM drive and press the Enter key.

- 4 Review and accept the installation agreements in the installation window. Then, click **Next**.



# Wireless network setup

- 5 Select **Wireless** on the **Printer Connection Type** screen. Then, click **Next**.
- 6 On the **Are you setting up your printer for the first time?** screen, select **Yes, I will set up my printer's wireless network**. Then, click **Next**.  
If your printer is already connected on the network, select **No, my printer is already connected to my network**.
- 7 Select **Using a USB cable** on the **Select the Wireless Setup Method** screen. Then, click **Next**.
- 8 After searching, the window shows the wireless network devices. Select the name (SSID) of the access point you want to use and click **Next**.



If you cannot find the network name you want to choose, or if you want to set the wireless configuration manually, click **Advanced Setting**.

- **Enter the wireless Network Name:** Enter the SSID of the access point (SSID is case-sensitive).
- **Operation Mode:** Shows the **Infrastructure**.
- **Authentication:** Select an authentication type.
  - Open System:** Authentication is not used, and encryption may or may not be used, depending on the need for data security.
  - Shared Key:** Authentication is used. A device that has a proper WEP key can access the network.
  - WPA Personal or WPA2 Personal:** Select this option to authenticate the print server based on a WPA Pre-Shared Key. This uses a shared secret key (generally called Pre Shared Key pass phrase), which is manually configured on the access point and each of its clients.

- **Encryption:** Select the encryption (None, WEP64, WEP128, TKIP, AES).
- **Network Password:** Enter the encryption network password value.
- **Confirm Network Password:** Confirm the encryption network password value.
- **WEP Key Index:** If you are using WEP Encryption, select the appropriate **WEP Key Index**.  
The wireless network security window appears when the access point has security settings.  
Enter the Network Password of the access point (or router).

- 9 If the Wi-Fi Direct feature is turned off in the machine, the following screen appears.  
Click **Next**.

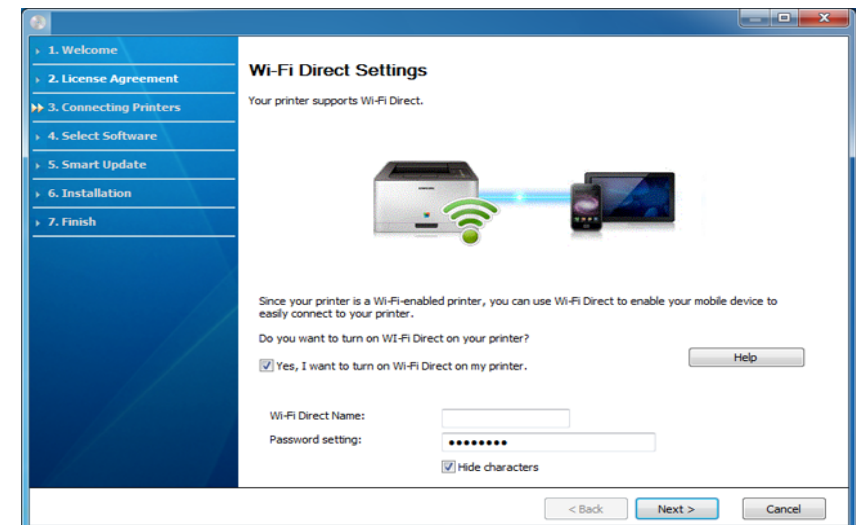

# Wireless network setup



- Wi-Fi Direct option appears on the screen only if your printer supports this feature.
- You can start to build Wi-Fi Direct by using the control panel (see "Setting up Wi-Fi Direct" on page 186).
- **Wi-Fi Direct Name:** The default Wi-Fi Direct Name is the model name and the maximum length is 23 characters.
- **Password setting** is the numeric string, and the size is 8 ~ 64 characters.

- 10 When the wireless network set up is completed, disconnect the USB cable between the computer and machine. Click **Next**.
- 11 Select the components to be installed.
- 12 Follow the instructions in the installation window.

## Setup using Mac

### Items to prepare

- Access point
- Network-connected computer
- Software CD that was provided with your machine
- A machine installed with a wireless network interface
- USB cable

## Setting up via USB cable

- 1 Make sure that the machine is connected to your computer and powered on.
- 2 Download the software from the Samsung website then unpack and install it: (<http://www.samsung.com> > find your product > Support or Downloads).
- 3 Turn on the machine.
- 4 Double-click the **Install Software** icon.
- 5 Double-click **Install Software** icon.
- 6 Read the license agreement and check installation agreement button.
- 7 Click **Next**.
- 8 Select **Wireless** on the **Printer Connection Type**.
- 9 Click **Next**.
- 10 On the **Select the Wireless Setup Method** screen, select **Using a USB cable**, and then click **Next**.  
If the screen dose not appear, go to step 14.
- 11 After searching, the window shows the wireless network devices. Select the name (SSID) of the access point you want to use and click **Next**.

# Wireless network setup



When you set the wireless configuration manually, click **Advanced Setting**.

- **Enter the wireless Network Name:** Enter the SSID of the access point (SSID is case-sensitive).
- **Operation Mode:** Shows the **Infrastructure**.
- **Authentication:** Select an authentication type.  
**Open System:** Authentication is not used, and encryption may or may not be used, depending on the need for data security.  
**Shared Key:** Authentication is used. A device that has a proper WEP key can access the network.  
**WPA Personal or WPA2 Personal:** Select this option to authenticate the print server based on the WPA Pre-Shared Key. This uses a shared secret key (generally called Pre Shared Key pass phrase) that is manually configured on the access point and each of its clients.
- **Encryption:** Select the encryption. (None, WEP64, WEP128, TKIP, AES)
- **Network Key:** Enter the encryption network key value.
- **Confirm Network Key:** Confirm the encryption network key value.
- **WEP Key Index:** If you are using WEP Encryption, select the appropriate **WEP Key Index**.

The wireless network security window appears when the access point has security enabled.

Enter the Network Key of the access point (or router).

- 12 The window showing the wireless network setting appears. Check the settings and click **Next**.



- You can start Wi-Fi Direct by using the control panel (see "Setting up Wi-Fi Direct" on page 186).
- **Wi-Fi Direct Name:** The default Wi-Fi Direct Name is the model name and the maximum length is 23 characters.
- **Password setting** is the numeric string, and the size is 8 ~ 64 characters.

- 13 The **Wireless Network Setting Complete** window appears. Click **Next**.
- 14 When the wireless network settings are completed, disconnect the USB cable between the computer and machine. Click **Next**.
- 15 Follow the instructions in the installation window.

# Wireless network setup

## Using a network cable



See your network administrator, or the person that set up your wireless network, for information about your network configuration.

Your machine is a network compatible machine. To enable your machine to work with your network, you will need to perform some configuration procedures.

## Items to prepare

- Access point
- Network-connected computer
- Software CD that was provided with your machine
- A machine installed with a wireless network interface
- Network cable

## Printing a network configuration report

You can identify the network settings of your machine by printing a network configuration report.

See "Printing a network configuration report" on page 164.

## IP setting using SetIP Program (Windows)

This program is used to manually set the network IP address of your machine using its MAC address to communicate with the machine. The MAC address is the hardware serial number of the network interface and can be found in the **Network Configuration Report**.

See "Setting IP address" on page 164.

## Configuring the machine's wireless network

Before starting you will need to know the network name (SSID) of your wireless network and the network key if it is encrypted. This information was set when the access point (or wireless router) was installed. If you do not know about your wireless environment, please ask the person who set up your network.

To configure wireless parameters, you can use **SyncThru™ Web Service**.

## Using SyncThru™ Web Service

Before starting wireless parameter configuration, check the cable connection status.

# Wireless network setup

- 1 Check whether the machine is connected to the network.
- 2 Start a web browser such as Internet Explorer, Safari, or Firefox and enter your machine's new IP address in the browser window.

For example,



- 3 Click **Login** in the upper right of the SyncThru™ Web Service website.
- 4 Type in the **ID** and **Password**, then click **Login**. If it's your first time logging into SyncThru™ Web Service, type in the below default ID and password. We recommend you to change the default password for security reasons.
  - **ID: admin**
  - **Password: sec00000**
- 5 When the **SyncThru™ Web Service** window opens, click **Settings > Network Settings**.
- 6 Click **Wi-Fi > Wizard**.
- 7 Select the one **Network Name(SSID)** in the list.
- 8 Click **Next**.  
If the wireless security setting window appears, enter the registered password (network password) and click **Next**.
- 9 The confirmation window appears, please check your wireless setup. If the setup is right, click **Apply**.



If a network cable is plugged into the network port, remove it from the network port.

## Turning the Wi-Fi network on/off

- 1 Check whether the machine is connected to the network.
- 2 Start a web browser such as Internet Explorer, Safari, or Firefox and enter your machine's new IP address in the browser window.

For example,

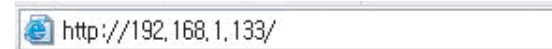

- 3 Click **Login** in the upper right of the SyncThru™ Web Service website.
- 4 Type in the **ID** and **Password**, then click **Login**. If it's your first time logging into SyncThru™ Web Service, type in the below default ID and password. We recommend you to change the default password for security reasons.
  - **ID: admin**
  - **Password: sec00000**
- 5 When the **SyncThru™ Web Service** window opens, click **Settings > Network Settings**.
- 6 Click **Wi-Fi**.
- 7 You can turn the Wi-Fi network on/off.

# Wireless network setup

## Setting the Wi-Fi Direct for mobile printing

Wi-Fi Direct is a secure and easy-to-use peer-to-peer connection between a Wi-Fi Direct-enabled printer and mobile device.

With Wi-Fi Direct, you can connect your printer to a Wi-Fi Direct network while concurrently connecting to an access point. You can also use a wired network and a Wi-Fi Direct network simultaneously so multiple users can access and print documents both from Wi-Fi Direct and from a wired network.



- You cannot connect your mobile device to the internet through the printer's Wi-Fi Direct.
- The supported protocol list may differ from your model, Wi-Fi Direct networks do NOT support IPv6, network filtering, IPSec, WINS, and SLP services.
- The maximum number of devices that can be connected via Wi-Fi Direct is 4.

## Setting up Wi-Fi Direct

You can enable Wi-Fi Direct feature by one of the following methods.

### From the machine

- 1 Select  (**Menu**) > **Network** > **Wi-Fi** > **Wi-Fi Direct** on the control panel.

OR

For models that have the touch screen on the control panel, press  (**Setup**) > **Machine Setup** > **Next** > **Network Setup** > **Wi-Fi** > **Wi-Fi Direct** on the touch screen.

- 2 Enable **Wi-Fi Direct**.

### From the network-connected computer

If your printer is using a network cable or a wireless access point, you can enable and configure Wi-Fi Direct from SyncThru™ Web Service.

- 1 Access **SyncThru™ Web Service** and select **Settings** > **Network Settings** > **Wi-Fi** > **Wi-Fi Direct™**.
- 2 Enable **Wi-Fi Direct™** and set other options.

# Wireless network setup

## Setting up the mobile device

- After setting up Wi-Fi Direct from the printer, refer to the user manual of the mobile device you are using to set its Wi-Fi Direct.
- After setting up Wi-Fi Direct, you need to download the mobile printing application (For example: Samsung Mobile printer) to print from your smartphone.



- When you have found the printer you want to connect to from your mobile device, select the printer and the printer's LED will blink. Press the option you want when the Wi-Fi connection confirmed window appears from the display screen and it will be connected to your mobile device.
- If your mobile device does not support Wi-Fi Direct, you need to enter the "Network Key" of a printer.

## Troubleshooting for wireless network

### Problems during setup or driver installation

#### Printers Not Found

- Your machine may not be turned on. Turn on your computer and the machine.
- USB cable is not connected between your computer and machine. Connect the machine to your computer using the USB cable.

- The machine does not support wireless networking. Check the machine's user's guide included on the software CD supplied with your machine and prepare a wireless network machine.

#### Connecting Failure - SSID Not Found

- The machine is unable to find the network name (SSID) you have selected or entered. Check the network name (SSID) on your access point and try connecting again.
- Your access point is not turned on. Turn on your access point.

#### Connecting Failure - Invalid Security

- Security is not configured correctly. Check the configured security on your access point and machine.

#### Connecting Failure - General Connection Error

- Your computer is not receiving a signal from your machine. Check the USB cable and your machine's power.

#### Connecting Failure - Connected Wired Network

- Your machine is connected with a wired network cable. Remove the wired network cable from your machine.

#### Connecting Failure - Assigning the IP address

- Cycle the power for the access point (or wireless router) and machine.

# Wireless network setup

## PC Connection Error

- The configured network address is unable to connect between your computer and machine.
  - For a DHCP network environment  
The printer receives the IP address automatically (DHCP) when computer is configured to DHCP.





If the printing job is not working in DHCP mode, the problem may be caused by the automatically changed IP address. Compare the IP address between the product's IP address and the printer port's IP address.

### How to compare:

- 1 Print the network information report of your printer, and then check the IP address (see "Printing a network configuration report" on page 164).
- 2 Check the printer port's IP address from your computer.
  - a Click the Windows **Start** menu.
  - b For Windows XP/Server 2003, select **Printer and Faxes**.
    - For Windows Server 2008/Vista, from the **Start** menu, select **Control Panel > Hardware and Sound > Printers**.
    - For Windows 7, from the **Start** menu, select **Control Panel > Devices and Printers**.  
For Windows 8, from the **Charms**, select **Search > Settings > Control Panel > Devices and Printers**.
    - For Windows Server 2008 R2, select **Control Panel > Hardware > Devices and Printers**.
    - For Windows 10 / Windows Server 2016  
From task bar, type in **Devices and Printers** in **Search** input area. Press the Enter key.

OR

From the **Start** () icon, select **Settings > Devices > Printers & scanners > Devices and Printers**.

Right-click the **Start** () icon, you can select **Control Panel > Devices and Printers**.

- c Right-click your machine.
  - d For Windows XP/2003/2008/Vista, press **Properties**.  
For Windows 7/8, Windows Server 2008 R2, Windows 10, or Windows Sever 2016 from context menus, select the **Printer properties**.  
If **Printer properties** item has ► mark, you can select other printer drivers connected with selected printer.
  - e Click **Port** tab.
  - f Click **Configure Port..** button.
  - g Check if **Printer Name** or **IP Address:** is the IP address on the network configuration Sheet.
- 3 Change the printer port's IP address if it is different from the network information report's.  
If you want to use the software installation CD to change the port IP, connect to a network printer. Then reconnect the IP address.

- For a Static network environment  
The machine uses the static address when the computer is configured to static address.  
For example,  
If the computer's network information is as shown below:
  - IP address: 169.254.133.42
  - Subnet Mask: 255.255.0.0



# Wireless network setup

Then the machine's network information should be as below:

- IP address: 169.254.133.43
- Subnet Mask: 255.255.0.0 (Use the computer's subnet mask.)
- Gateway: 169.254.133.1

## Other problems

---

If problems occur while using the machine on a network, check the following:



For information on the access point (or wireless router), refer to its own user's guide.

- Your computer, access point (or wireless router), or machine may not be turned on.
- Check the wireless reception around the machine. If the router is far from the machine or there is an obstacle, you might have difficulty receiving the signal.
- Cycle the power for the access point (or wireless router), machine, and computer. Sometimes cycling the power can recover network communication.

- Check whether firewall software (V3 or Norton) is blocking the communication.

If the computer and the machine are connected on the same network and it cannot be found when searching, firewall software might be blocking the communication. Refer to the user's guide for the software to turn it off and try searching for the machine again.

- Check whether the machine's IP address is allocated correctly. You can check the IP address by printing the network configuration report.
- Check whether the access point (or wireless router) has a configured security (password). If it has a password, refer to the access point (or wireless router) administrator.
- Check the machine's IP address. Reinstall the machine driver and change the settings to connect to the machine on the network. Due to the characteristics of DHCP, the allocated IP address could change if the machine is not used for a long time or if the access point has been reset.  
Register the product's MAC address when you configure the DHCP server on the access point (or wireless router). Then you can always use the IP address that is set with the MAC address. You can identify the Mac address of your machine by printing a network configuration report.
- Check the wireless environment. You might not be able to connect to the network in the infrastructure environment where you need to type in a user's information before connecting to the access point (or wireless router).
- This machine only supports IEEE 802.11 b/g/n and Wi-Fi. Other wireless communication types (e.g., Bluetooth) are not supported.
- The machine is within the range of the wireless network.

# Wireless network setup

- The machine is located away from obstacles that could block the wireless signal.  
Remove any large metal objects between the access point (or wireless router) and the machine.  
Make sure the machine and wireless access point (or wireless router) are not separated by poles, walls, or support columns containing metal or concrete.
- The machine is located away from other electronic devices that may interfere with the wireless signal.  
Many devices can interfere with the wireless signal, including a microwave oven and some Bluetooth devices.
- Whenever the configuration of your access point (or wireless router) changes, you must do the product's wireless network setup again.
- The maximum number of devices that can be connected via Wi-Fi Direct is 4.
- If the access point is set to work with the 802.11n standard only, it may not connect to your machine.

# Using the NFC feature



For C306xND and C306xFR, check the option lists and contact the purchasing point to order (see "Available accessories" on page 83). After installing the Wireless/NFC kit (Optional), set the machine to use this feature.

The NFC (Near Field Communication) printer allows you to directly print from your mobile device just by holding your mobile device over the NFC tag on Wireless/NFC Kit (Wireless LAN Option). It does not require installing print driver or connecting to an access point. You just need NFC supported mobile device. In order to use this feature, mobile apps needs to be installed on your mobile device.



- Depending on the material of the mobile device cover, NFC recognition may not work properly.
- Depending on the mobile device you are using, the transmission speed may differ.
- This feature is available only for the model with a NFC tag.
- Using a cover or a battery other than the ones that came with the mobile device, or a metal cover/sticker can block NFC.
- If NFC devices keep failing to communicate,
  - Remove the case or cover from the mobile device, then try again.
  - Reinstall the battery from the mobile device, then try again.

## Requirements

- NFC and Wi-Fi Direct enabled, supported mobile apps installed mobile device with Android OS 4.0 or higher.



Only Android OS 4.1 or higher will automatically enable the Wi-Fi Direct feature on your mobile device when you enable the NFC feature. We recommend you to upgrade your mobile device to Android OS 4.1 or higher to use the NFC feature.

- Wi-Fi Direct feature enabled printer (see "Setting the Wi-Fi Direct for mobile printing" on page 186).

## Related Apps

There are some apps that can be used with the NFC feature. The apps can be downloaded from the Google Play Store.

- **Samsung Mobile Print:** Enables users to print, scan (Only users with the machine supports scan), or fax (Only users with the machine supports fax) photos, documents, and web pages directly from your smartphone or tablet (see "Using the Samsung Mobile Print App" on page 197).
- **Samsung Mobile Print Control:** Helps users to get an authentication easily. This app provides one way of getting a user authentication using your mobile device (see "Using the Samsung Mobile Print Control App" on page 192).
- **Samsung Mobile Print Manager:** Enables users to use cloning and wireless setup features using your mobile device (see "Using the Samsung Mobile Print Manager App" on page 194).

# Using the NFC feature

## Using the Samsung Mobile Print Control App



This App is not supported for C306xFW.

You can use it to get an authentication/registration from the **Samsung Mobile Print Control** app.

## Authentication from the mobile device

**1** Check that NFC and Wi-Fi Direct enabled features are on your mobile device and Wi-Fi Direct feature is enabled on your printer.

**2** Open **Samsung Mobile Print Control** app.



If you do not have **Samsung Mobile Print Control** installed on your cellphone, go to the application store (Samsung Apps, Play Store, App Store) on your mobile device, and just search for download the app and try again.

**3** Type in the **ID** and **Password**.

- **ID: admin**
- **Password: sec00000**

**4** Tag your mobile device (usually located on the back of the mobile device) over the NFC tag (NFC) on your printer.

Wait few seconds for the mobile device to connect to the printer.

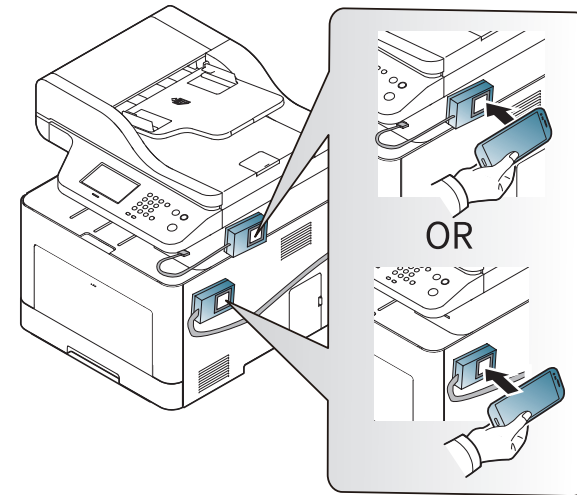



For some mobile devices, NFC tag might not be located at the back of the mobile device. Check the location of the NFC antenna on your mobile device before tagging.

# Using the NFC feature

## Registration from the mobile device

- 1 Check that NFC and Wi-Fi Direct enabled features are on your mobile device and Wi-Fi Direct feature is enabled on your printer.
- 2 Open **Samsung Mobile Print Control** app.

 If you do not have **Samsung Mobile Print Control** installed on your cellphone, go to the application store (Samsung Apps, Play Store, App Store) on your mobile device, and just search for download the app and try again.

- 3 Press the  icon on the **Samsung Mobile Print Control** screen.
- 4 Select **On** from the **Phone login set as default** menu.
- 5 Mobile device ID appears on the **Samsung Mobile Print Control** screen. Press **Registration**.
- 6 Type in the **ID** and **Password**.
  - **ID: admin**
  - **Password: sec00000**

 • **Passcode** is for when the administrator chooses **Two-Factor Authentication** method. You need to enter a passcode for authentication. Password and passcode should be different. You can select **Two-Factor Authentication** from the SyncThru™ Web Service, select **Security > User Access Control > Authentication > Authentication Method > Options** button > **Login Method > Two-Factor Authentication**.

- 7 Tag your mobile device (usually located on the back of the mobile device) over the NFC tag () on your printer.

Wait few seconds for the mobile device to connect to the printer.

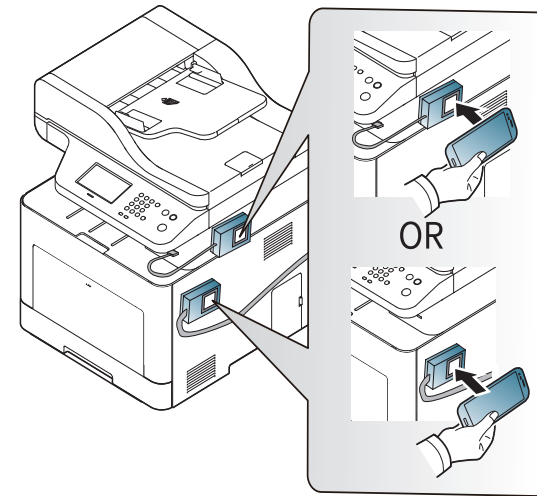

 For some mobile devices, NFC tag might not be located at the back of the mobile device. Check the location of the NFC antenna on your mobile device before tagging.

- 8 Registration complete message appears on the printer's touch screen.

# Using the NFC feature

## Using the Samsung Mobile Print Manager App



This App is not supported for C306xFW.

If you have more than one printer and need to set the same settings on each printer, you can easily do it using the **Samsung Mobile Print Manager** app. Touch your cellphone on the NFC tag on your printer to copy the settings and tap on the printer you want to set the setting.



When exporting the data, you can save more than one data. When importing the data, you can select the data from the list and import.

## Exporting(Copying the setting to your mobile device)

- 1 Check that NFC and Wi-Fi Direct enabled features are on your mobile device and Wi-Fi Direct feature is enabled on your printer.
- 2 Open **Samsung Mobile Print Manager** from your mobile device.



If you do not have **Samsung Mobile Print Manager** installed on your cellphone, go to the application store (Samsung Apps, Play Store) on your mobile device, and just search for download the app and try again.

- 3 Press **Export**.
- 4 Type in the **ID** and **Password**.
  - **ID: admin**
  - **Password: sec00000**
- 5 Tag your mobile device (usually located on the back of the mobile device) over the NFC tag (NFC) on your printer.  
Wait few seconds for the mobile device to connect to the printer.

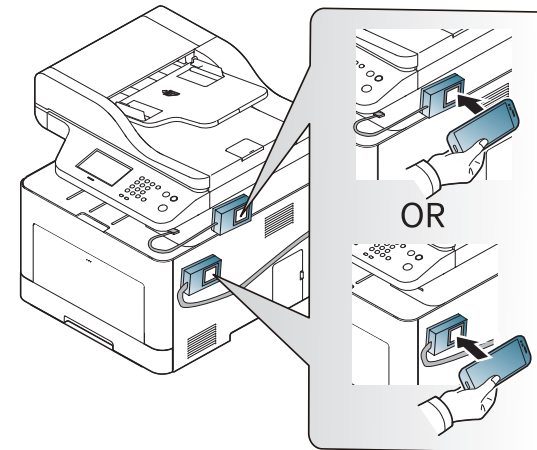

# Using the NFC feature



- For some mobile devices, NFC tag might not be located at the back of the mobile device. Check the location of the NFC antenna on your mobile device before tagging.
- While cloning, the machine is locked.

**6** Select the settings you want to apply and press **OK**.

**7** Follow the instruction on the mobile device's screen.

## Importing (Applying the settings to the machine)

**1** Check that NFC and Wi-Fi Direct enabled features are on your mobile device and Wi-Fi Direct feature is enabled on your printer.

**2** Open **Samsung Mobile Print Manager** from your mobile device.



If you do not have **Samsung Mobile Print Manager** installed on your cellphone, go to the application store (Samsung Apps, Play Store) on your mobile device, and just search for download the app and try again.

**3** Press **Import**.

**4** Type in the **ID** and **Password**.

- **ID: admin**
- **Password: sec00000**

**5** Select the settings you want to copy.

**6** Follow the instruction on the mobile device's screen.

**7** Tag your mobile device (usually located on the back of the mobile device) over the NFC tag (NFC) on your printer.

Wait few seconds for the mobile device to connect to the printer.

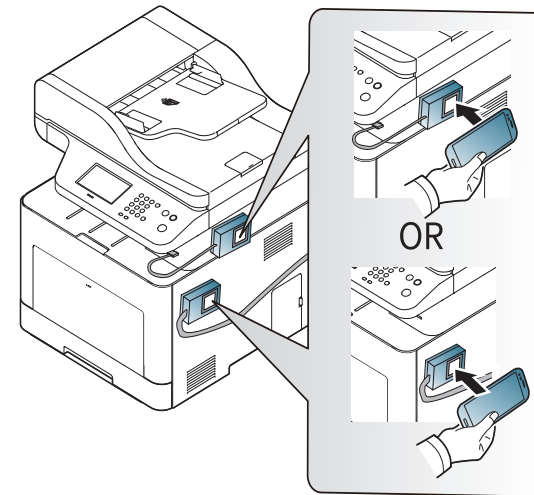

- For some mobile devices, NFC tag might not be located at the back of the mobile device. Check the location of the NFC antenna on your mobile device before tagging.
- While cloning, the machine is locked.

# Using the NFC feature

## Wireless Setup

You can copy wireless setting from your phone to your printer by touching your mobile device on the NFC tag on your printer.

- 1 Check that NFC and Wi-Fi Direct enabled features are on your mobile device and Wi-Fi Direct feature is enabled on your printer.
- 2 Open **Samsung Mobile Print Manager** from your mobile device.



If you do not have **Samsung Mobile Print Manager** installed on your cellphone, go to the application store (Samsung Apps, Play Store) on your mobile device, and just search for download the app and try again.

- 3 Mobile device **Samsung Mobile Print Control** screen appears.  
Press **Wi-Fi Setup**.

- 4 Type in the **ID** and **Password**.

- **ID: admin**
- **Password: sec00000**

- 5 If the access point (or wireless router) is connected to the connection confirmation window appears, then click **OK**.

If the access point (or wireless router) not connection, select the desired access point (or wireless router) and click **OK**, then click **OK**.

- 6 Tag your mobile device (usually located on the back of the mobile device) over the NFC tag (NFC) on your printer.

Wait few seconds for the mobile device to connect to the printer.

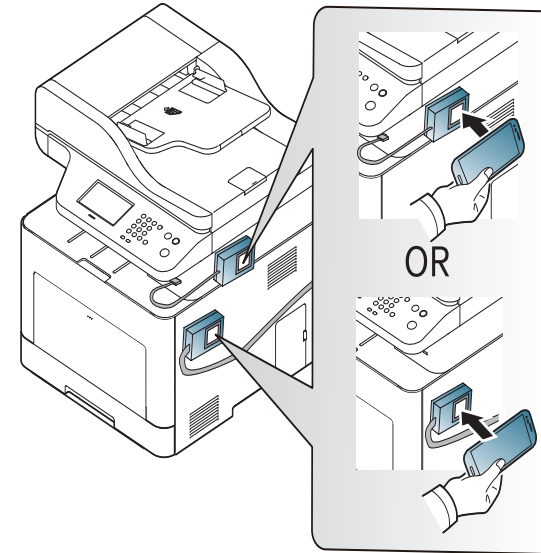

For some mobile devices, NFC tag might not be located at the back of the mobile device. Check the location of the NFC antenna on your mobile device before tagging.

- 7 Follow the instruction on the mobile device's screen.



# Using the NFC feature

## Using the Samsung Mobile Print App

**Samsung Mobile Print** is a free application that enables users to print, scan(Only users with multi-functional printers), or fax(Only users with multi-functional printers) photos, documents, and web pages directly from your smartphone or tablet.

## Printing

- 1 Check that NFC and Wi-Fi Direct features are enabled on your mobile device and Wi-Fi Direct feature is enabled on your printer.
- 2 Open **Samsung Mobile Print** app.

 If you do not have **Samsung Mobile Print** installed on your cellphone, go to the application store (Samsung Apps, Play Store, App Store) on your mobile device, and just search for download the app and try again.

- 3 Select print mode.
- 4 Select the content you want to print.

If necessary, change the print option by pressing the  icon.

- 5 Tag your mobile device (usually located on the back of the mobile device) over the NFC tag () on your printer.

Wait a few seconds for the mobile device to send a job to the printer.

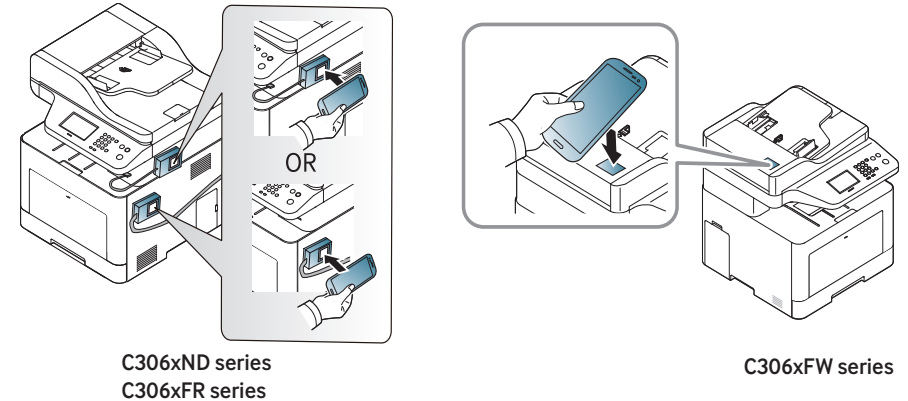

 For some mobile devices, NFC tag might not be located at the back of the mobile device. Check the location of the NFC antenna on your mobile device before tagging.

- 6 The printer starts printing.

## Scanning

- 1 Check that NFC and Wi-Fi Direct features are enabled on your mobile device and Wi-Fi Direct feature is enabled on your printer.
- 2 Open **Samsung Mobile Print** app.

# Using the NFC feature



If you do not have **Samsung Mobile Print** installed on your cellphone, go to the application store (Samsung Apps, Play Store, App Store) on your mobile device, and just search for download the app and try again.

**3** Select scan mode.

**4** Place a single document face down on the document glass, or load the documents face up into the document feeder (see "Loading originals" on page 54).

If necessary, change the scan option by pressing the .

**5** Tag your mobile device (usually located on the back of the mobile device) over the NFC tag () on your printer.

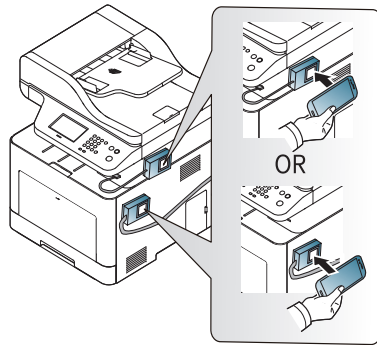

C306xND series  
C306xFR series

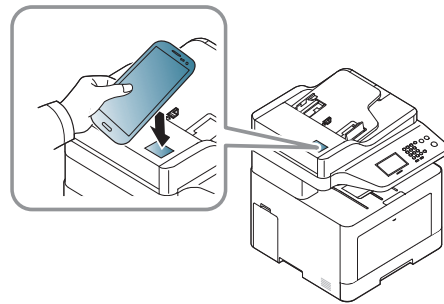

C306xFW series



For some mobile devices, NFC tag might not be located at the back of the mobile device. Check the location of the NFC antenna on your mobile device before tagging.

**6** The printer starts scanning the content.  
The scanned data is saved on your mobile device.



If you want to continue scanning, follow the instruction on the app screen.

## Sending Fax

**1** Check that NFC and Wi-Fi Direct features are enabled on your mobile device and Wi-Fi Direct feature is enabled on your printer.

**2** Open **Samsung Mobile Print** app.





If you do not have **Samsung Mobile Print** installed on your cellphone, go to the application store (Samsung Apps, Play Store, App Store) on your mobile device, and just search for download the app and try again.

**3** Select fax mode.

# Using the NFC feature

- 4 Select the content you want to send fax.

If necessary, enter the fax number and change the fax option by pressing the  icon.

- 5 Tag your mobile device (usually located on the back of the mobile device) over the NFC tag () on your printer.

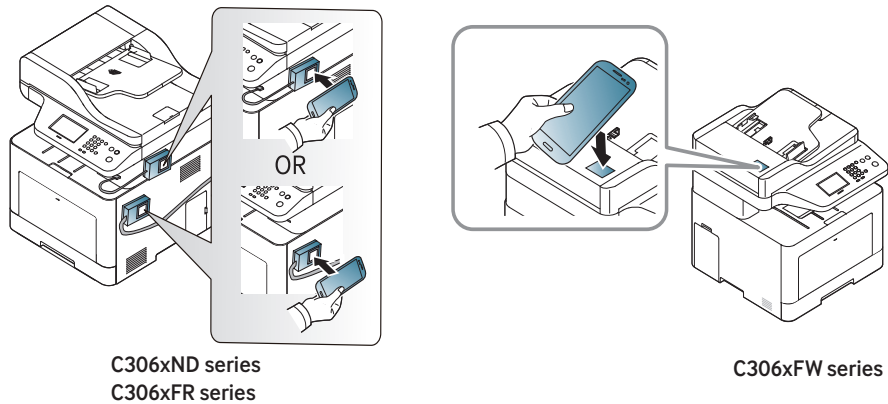

For some mobile devices, NFC tag might not be located at the back of the mobile device. Check the location of the NFC antenna on your mobile device before tagging.

- 6 The printer starts faxing the content.

# Supported Mobile Apps

## Available Apps

- **Samsung Mobile Print:** **Samsung Mobile Print** is a free application that enables users to print, scan(Only users with the machine supports scan), or fax(Only users with the machine supports fax) photos, documents, and web pages directly from your smartphone or tablet. **Samsung Mobile Print** is not only compatible with your Android and iOS smart phones but also with your iPod Touch and tablet PC. It connects your mobile device to a network connected Samsung printer or to a wireless printer through a Wi-Fi access point. Installing a new driver or configuring network settings isn't necessary – just simply install the **Samsung Mobile Print** application, and it will automatically detect compatible Samsung printers. Besides printing photos, web pages, and PDFs, scanning is also supported. If you have a Samsung multifunction, scan any document into a JPG, PDF, or PNG format for quick and easy viewing on your mobile device (see "Using the Samsung Mobile Print App" on page 197).
- **Samsung Mobile Print Control:** Helps users to get an authentication easily. This app provides one way of getting a user authentication using your mobile device (see "Using the Samsung Mobile Print Control App" on page 192).
- **Samusng Mobile Print Manager:** Enables users to use cloning and wireless setup features using your mobile device (see "Using the Samsung Mobile Print Manager App" on page 194).

## Downloading Apps

To download apps, go to the application store (Play Store, App Store) on your mobile device, and just search for "**Samsung Mobile Print /Samsung Mobile Print Control/Samusng Mobile Print Manager.**" You can also visit iTunes for Apple devices on your computer.

- **Samsung Mobile Print/ Samsung Mobile Print Control**
  - **Android:** Search for **Samsung Mobile Print** or **Samsung Mobile Print Control** from Play Store, and then download the app.
  - **iOS:** Search for **Samsung Mobile Print** or **Samsung Mobile Print Control** from App Store, and then download the app.
- **Samusng Mobile Print Manager**
  - **Android:** Search for **Samusng Mobile Print Manager** from Play Store, and then download the app.

## Supported Mobile OS

- **Samsung Mobile Print / Samsung Mobile Print Control**
  - Android OS 4.0 or higher
  - iOS 8.0 or higher
- **Samusng Mobile Print Manager**
  - Android OS 4.0 or higher



Only Mopria-certified machines can use the **Mopria** feature. Check the box that your machine came in for the Mopria-certified logo.



**Mopria™** Print Service is a mobile printing solution that enhances the new print functionality on any Android phone or tablet (Android version 4.4 or later). With this service, you can connect and print to any Mopria-certified printer on the same network as your mobile device without additional set-up. Many native Android apps support printing, including Chrome, Gmail, Gallery, Drive and Quickoffice.

## Setting up the machine for Mopria printing

Bonjour(mDNS) and IPP protocols are required on your machine to use the **Mopria** feature. Perform the following steps to enable the **Mopria** feature.

- 1 Check whether the machine is connected to the network.
- 2 Start a web browser such as Internet Explorer, Safari, or Firefox and enter your machine's new IP address in the browser window.

For example,



- 3 Click **Login** in the upper right of the SyncThru™ Web Service website.

- 4 Type in the **ID** and **Password**, then click **Login**. If it's your first time logging into SyncThru™ Web Service, type in the below default ID and password. We recommend you to change the default password for security reasons.
  - **ID: admin**
  - **Password: sec00000**
- 5 When the SyncThru™ Web Service window opens, click **Settings** > **Network Settings** > **Standard TCP/IP, LPR, IPP** > **IPP**. Then, select **Enable**.
- 6 Click **Settings** > **Network Settings** > **mDNS**. Then, select **Enable**.
- 7 Click **Security** > **System Security** > **Feature Management** > **Mopria**. Then, select **Enable**.

## Setting up Mopria on your mobile device

If you do not have **Mopria Print Service** app installed on your mobile device, open to the app store (Play Store, App Store) on your mobile device, search for, **Mopria Print Service**, and then download and install the app.

- 1 In the **Settings** menu of your Android device, tap **Printing**.



The location of this option may differ depending on your mobile device. If you cannot locate the **Printing** option, refer to the user's manual for your mobile device.

- 2 Under **Print Services**, tap **Mopria Print Service**.
- 3 Tap the **On/Off** slider to enable the **Mopria Print Service**.

## Printing via Mopria

To print via Mopria on an Android device:

- 1 Open the email, photo, web page, or document that you want to print.
- 2 Tap **Print** on the menu in the app.
- 3 Select **your printer**, and then configure the print options.
- 4 Touch **Print** again to print the document.



**To cancel a print job:** Select and delete the document from the print queue in the **Notification Bar**.

# AirPrint



Only AirPrint certified machines can use the AirPrint feature. Check the box your machine came in for the AirPrint certified mark.



**AirPrint** allows you to print directly from Mac OS (MacBook Pro, MacBook Air, and iMAC) and iOS (iPhone, iPad and iPod touch).

Scan and Fax are available only for Mac OS. (Only users with multi-functional printers)

## Setting up AirPrint

Bonjour(mDNS) and IPP protocols are required on your machine to use the **AirPrint** feature. You can enable the **AirPrint** feature by one of the following methods.

- 1 Check whether the machine is connected to the network.
- 2 Start a web browser such as Internet Explorer, Safari, or Firefox and enter your machine's new IP address in the browser window.

For example,

A screenshot of a browser address bar showing the URL 'http://192.168.1.133/'.

- 3 Click **Login** in the upper right of the SyncThru™ Web Service website.

- 4 Type in the **ID** and **Password**, then click **Login**. If it's your first time logging into SyncThru™ Web Service, type in the below default ID and password. We recommend you to change the default password for security reasons.

- **ID: admin**
- **Password: sec00000**

- 5 When the SyncThru™ Web Service window opens, click **Settings > Network Settings**.

- 6 Click **AirPrint**.

## Using the AirPrint

**AirPrint** is a free application that enables users to print, scan (Only users with multi-functional printers), or fax (Only users with multi-functional printers built -in fax) from Mac OS and iOS. Scan and Fax are available only for Mac OS (Only users with multi-functional printers).



For instruction on how to print, scan, and fax, refer to Mac Help.

# Samsung Cloud Print

Samsung Cloud Print is a free cloud service that allows you to print or scan from your smartphone or tablet to your Samsung printer or MFP. After installing the Samsung Cloud Print app, you can register with the Samsung Cloud Print service just using your mobile number for authentication. No other account login is required, although you can link the app to your Samsung Account if you wish.

Refer to the Samsung website ([www.samsungcloudprint.com](http://www.samsungcloudprint.com)) for more information about Samsung Cloud Print.



If you press the (  ) button from Samsung Cloud Print app, connect your mobile device to a printer or MFP by using Wi-Fi Direct, touching the Near Field Communication (NFC) tag, scanning the QR code, or manually entering the printer's MAC address. Once paired, you can print or scan from anywhere and everywhere.

## Registering your Printer to Samsung Cloud server

### Registering from Web Browser



Make sure the printer machine is turned on and connected to a wired or wireless network that has access to the Internet.

- 1 Check whether the machine is connected to the network.
- 2 Start a web browser such as Internet Explorer, Safari, or Firefox and enter your machine's new IP address in the browser window.

For example,

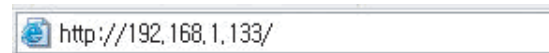

- 3 Click **Login** in the upper right of the SyncThru™ Web Service website.
- 4 Type in the **ID** and **Password**, then click **Login**. If it's your first time logging into SyncThru™ Web Service, type in the below default ID and password. We recommend you to change the default password for security reasons.
  - **ID: admin**
  - **Password: sec00000**
- 5 When the **SyncThru™ Web Service** window opens, click **Settings** > **Network Settings** > **Samsung Cloud Print**.



If the **XOA** tab is shown, press **XOA** > **Samusng Cloud Agent** from **SyncThru™ Web Service**.

- 6 Now your printer is registered with Samsung Cloud Print service.



# Samsung Cloud Print

## Using the Samsung Cloud Print



Make sure the printer is turned on and connected to a wired or wireless network that has access to the Internet.

## Registering a printer from an application on mobile device

The following steps are an example of using the **Samsung Cloud Print** app from Android mobile phone.

- 1 Open **Samsung Cloud Print** app.



If you do not have **Samsung Cloud Print** app installed on your cellphone, go to the application store (Samsung Apps, Play Store, App Store) on your mobile device, and just search for download the app and try again.

- 2 Press the () button from Samsung Cloud Print app.
- 3 Connect your mobile device to a printer or MFP by using Wi-Fi Direct, touching the Near Field Communication (NFC) tag, scanning the QR code, or manually entering the printer's MAC address.

## Printing from an application on mobile device

The following steps are an example of using the **Samsung Cloud Print** app from Android mobile phone.

- 1 Open **Samsung Cloud Print** app.



If you do not have **Samsung Cloud Print** app installed on your cellphone, go to the application store (Samsung Apps, Play Store, App Store) on your mobile device, and just search for download the app and try again.

- 2 Tap the option check button of the document that you want to print.
- 3 Set the printing options if you want.
- 4 Tap **Send Job**.

## Scanning and sending to Samsung Cloud Print

You can scan an image and the scanned data will be stored in the **Samsung Cloud Print**.

- 1 Place a single document face down on the document glass, or load the documents face up into the document feeder (see "Loading originals" on page 54).
- 2 Press **Samsung Cloud** from the control panel.

# Samsung Cloud Print

- 3 Enter recipient country code and recipient phone number.
- 4 Enter sender information.
- 5 Enter a file name to store the scan data.

 You can set the file name from the SyncThru™ Web Service. Open the Web browser from your networked computer and type the IP address of your machine. When SyncThru™ Web Service opens, click **Settings > Machine Settings > Samsung Cloud > File Name**.

- 6 Press the  (**Start**) button to scan and store the file in Samsung Cloud server.

 When the user is not registered in the **Samsung Cloud Print**, a confirmation window will pop up. Select a work in progress or not.

# PrinterOn

Registering your **PrinterOn**-enabled Samsung printer on the **PrinterOn** service allows you to print documents on that printer from anywhere in the world. The **PrinterOn** service also enables you to print directly from the **PrinterOn** Mobile app on your iOS or Android device. After installing the **PrinterOn** Mobile app, you can register your device on the **PrinterOn** service by using your mobile number for authentication.

To use the **PrinterOn** feature, you must register your printer on the **PrinterOn** website ([www.printeron.com](http://www.printeron.com)).

Only administrators can register or configure a printer on the **PrinterOn** service.

This chapter does not explain all the features in the **PrinterOn** service. Instead, it explains how to register a printer on the **PrinterOn** service from the control panel of the machine and the SyncThru™ Web Service.

For more information about the **PrinterOn** service, visit the **PrinterOn** website ([www.printeron.com](http://www.printeron.com)).

## Registering your printer on the PrinterOn service

To register your printer on the **PrinterOn** service, you must activate the **PrinterOn** feature on the machine through the control panel or SyncThru™ Web Service.

## Registering from the control panel



Before you begin this process, make sure that your printer is turned on and can connect to the Internet.

### Machines with a display screen

- 1 Select  (**Menu**) > **PrinterOn** from the display screen.
- 2 Press **OK**.
- 3 Press **Yes** to activate the **PrinterOn** feature.
- 4 Press **OK**.

Now, your printer is registered on the **PrinterOn** service.

### Machines with a touch screen

- 1 Tap **PrinterOn** from the touch screen.
- 2 When the pop-up window appears, tap **OK**.  
Now, your printer is registered on the **PrinterOn** service.

## Registering from Web Browser



Before you begin this process, make sure that your printer is turned on and can connect to the Internet.

- 1 Check whether the machine is connected to the network.
- 2 Start a web browser such as Internet Explorer, Safari, or Firefox and enter your machine's new IP address in the browser window.

For example,



- 3 Click **Login** in the upper right of the SyncThru™ Web Service website.
- 4 Type in the **ID** and **Password**, then click **Login**. If it's your first time logging into SyncThru™ Web Service, type in the below default ID and password. We recommend you to change the default password for security reasons.
  - **ID: admin**
  - **Password: sec00000**
- 5 When the **SyncThru™ Web Service** window opens, click **Settings** > **Network Settings** > **PrinterOn Cloud Print**.



If the **XOA** tab is shown, press **XOA** > **PrinterOn Cloud Print** from **SyncThru™ Web Service**.

- 6 Select **Enable** for the **PrinterOn Cloud Print Protocol** setting.
- 7 Click **Apply**.  
Now, your printer is registered on the **PrinterOn** service.

## Using the PrinterOn Service

For instruction on how to print using the **PrinterOn** service, refer to the **PrinterOn** service website ([www.printeron.com](http://www.printeron.com)).

# Google Cloud Print™

Google Cloud Print™ is a service that allows you to print to a printer using your smart phone, tablet, or any other web-connected devices. Just register your Google account with the printer, and you are ready to use the Google Cloud Print™ service. You can print your document or email with Chrome OS, Chrome browser, or a Gmail™/ Google Docs™ application on your mobile device, so you don't need to install the printer driver on the mobile device. Refer to the Google website (<http://google.com/cloudprint/learn/> or <http://support.google.com/cloudprint>) for more information about Google Cloud Print™.

## Registering your Google account to the printer

### Registering from the Chrome Browser



- Make sure the printer machine is turned on and connected to a wired or wireless network that has access to the Internet.
- You should create your Google account in the advance.

- 1 Open the Chrome browser.
- 2 Visit [www.google.com](http://www.google.com).
- 3 Sign in to the Google website with your Gmail™ address.
- 4 Enter your printer's IP address in the address field and press the Enter key or click **Go**.
- 5 Click **Login** in the upper right corner of the SyncThru™ Web Service website.

- 6 Type in the **ID** and **Password**, then click **Login**. If it's your first time logging into SyncThru™ Web Service, type in the below default ID and password. We recommend you to change the default password for security reasons.

- **ID: admin**
- **Password: sec00000**



If the network environment is using a proxy server, you need to configure the proxy's IP and port number from **Settings > Network Settings > Proxy**. Contact your network service provider or network administrator for more information.

- 7 When the **SyncThru™ Web Service** window opens, click **Settings > Network Settings > Google Cloud Print**.
- 8 Enter your printer's name and description.
- 9 Click **Register**.  
The confirmation pop-up window appears.



If you set the browser to block pop-ups, the confirmation window will not appear. Allow the site to show pop-ups.

- 10 Click **Finish printer registration**.
- 11 Click **Manage your printers**.  
Now your printer is registered with Google Cloud Print™ service.  
Google Cloud Print™-ready devices will appear in the list.

# Google Cloud Print™

## Printing with Google Cloud Print™

The printing procedure varies depending on the application or the device you are using. You can see the application list that supports Google Cloud Print™ service.



Make sure the printer is turned on and connected to a wired or wireless network that has access to the Internet.



## Printing from an application on mobile device

The following steps are an example of using the Google Docs™ app from Android mobile phone.

- 1 Install the Cloud Print application on your mobile device.



If you do not have the application, download it from the application store such as Android Market or App Store.

- 2 Access the Google Docs™ application from your mobile device.
- 3 Tap the option  button of the document that you want to print.
- 4 Tap the send  button.

- 5 Tap the Cloud Print  button.
- 6 Set the printing options if you want.
- 7 Tap **Click here to Print**.

## Printing from the Chrome browser

The following steps are an example of using the Chrome browser.

- 1 Run Chrome.
- 2 Open the document or email that you want to print.
- 3 Click the wrench icon  in the browser's top right corner.
- 4 Click **Print**. A new tab for printing appears.
- 5 Select **Print with Google Cloud Print**.
- 6 Click the **Print** button.



# 3. Useful Setting Menus

This chapter explains how to browse the current status of your machine, and the method of setting for advanced machine setup.

• <b>Before you begin reading a chapter</b>	<b>212</b>
• <b>Print</b>	<b>213</b>
• <b>Copy</b>	<b>215</b>
• <b>Fax</b>	<b>221</b>
• <b>Scan</b>	<b>225</b>
• <b>System setup</b>	<b>229</b>
• <b>Admin setup</b>	<b>242</b>
• <b>Eco</b>	<b>244</b>
• <b>Direct USB</b>	<b>245</b>
• <b>Job Status</b>	<b>246</b>
• <b>Document box</b>	<b>247</b>
• <b>PrinterOn</b>	<b>248</b>





# Before you begin reading a chapter

This chapter explains all the features available for this series' models to help users easily understand the features.

You can check the features available for each model in the Basic Guide (see "Menu overview" on page 28).

The following are tips for using this chapter



- The control panel provides access to various menus to set up the machine or use the machine's functions. These menus can be accessed by pressing  (**Menu**) or from the touch screen.
- Some menus may not appear on the display depending on options or models. If so, it is not applicable to your machine.
- For models that do not have the  (**Menu**) on the control panel, this feature is not applicable (see "Control panel overview" on page 21).
- Some menu names may differ from your machine depending on its options or the models.







Some menus may not appear in the display depending on options or models. If so, it is not applicable to your machine (see "Menu overview" on page 28).

To change the menu options:

- Press  (**Menu**) > **Print Setup** on the control panel.
- Or press  (**Setup**) > **Machine Setup** > **Next** > **Print Setup** on the touch screen.

Item	Description
<b>Orientation</b>	<p>Selects the direction in which information is printed on a page.</p> <ul style="list-style-type: none"> <li>• <b>Portrait</b></li> </ul>  <ul style="list-style-type: none"> <li>• <b>Landscape</b></li> </ul> 
<b>Duplex</b>	You can set the machine to print on both sides of paper.

Item	Description
<b>Copies</b>	You can enter the number of copies using the number keypad.
<b>Resolution</b>	Specifies the number of dots printed per inch (dpi). The higher the setting, the sharper printed characters and graphics.
<b>Clear Text</b>	Prints text darker than on a normal document.
<b>Emulation</b>	<p>Sets the emulation type and option.</p> <ul style="list-style-type: none"> <li>• <b>Emulation Type:</b> The machine language defines how the computer communicates with the machine.</li> <li>• <b>Setup:</b> Sets the detailed settings for the selected emulation type.</li> </ul>
<b>Edge Enhancement</b>	It allows user to enhance sharpness of text and graphics for improving readability.
<b>Auto CR</b>	Allows you to append the required carriage return to each line feed, which is useful for Unix or DOS users.
<b>Skip Blank Pages</b>	The printer detects the printing data from computer whether a page is empty or not. You can set to print or skip the blank page.
<b>Trapping</b>	It reduces the white gap caused by misalignment of color channels in color printing mode. Also black text will be overprinted on other colors.

Item	Description
<b>Screen</b>	<p>This option affect the resolution and clarity of your color output.</p> <ul style="list-style-type: none"><li>• <b>Normal:</b> This mode will generate printouts with smooth tone over the entire page.</li><li>• <b>Enhanced:</b> This mode will generate printouts with sharp texts and smooth graphic/photo objects in the page.</li><li>• <b>Detailed:</b> This mode will generate printouts with sharp details over the entire page.</li></ul>
<b>Paper Source</b>	Sets the select tray type.



# Copy

## Copy feature



Some menus may not appear in the display depending on options or models. If so, it is not applicable to your machine (see "Menu overview" on page 28).

To change the menu options:

- Press  (**Menu**) > **Copy Feature** on the control panel.
- Or press  (**Setup**) > **Machine Setup** > **Next** > **Default Setting** > **Copy Default** > **Common** on the touch screen.
- Or press  (**Copy**) > select the menu item you want on the touch screen.

Item	Description
<b>Original Size</b>	Sets the image size.
<b>Original Type</b>	Improves the copy quality by selecting the document type for the current copy job.
<b>Copies</b>	You can enter the number of copies using the number keypad.

Item	Description
<b>Reduce/Enlarge</b>	Reduces or enlarges the size of a copied image (see "Reduced or enlarged copy" on page 66).  If the machine is set to Eco mode, reduce and enlarge features are not available.
<b>Darkness</b>	Adjusts the brightness level to make a copy that is easier to read, when the original contains faint markings and dark images (see "Darkness" on page 65).
<b>Original Type</b>	Improves the copy quality by selecting the document type for the current copy job (see "Original Type" on page 65).
<b>Auto Color</b>	You can sets whether to use Auto color on or off. <ul style="list-style-type: none"><li>• <b>On:</b> Select this setting to automatically detect whether the scanned document is in color or black and white, and then select an appropriate color setting.</li></ul>

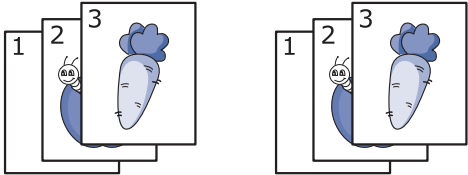
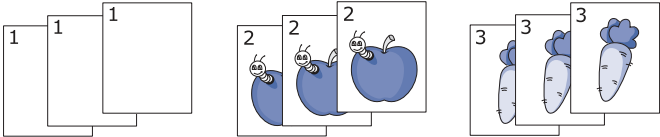

# Copy

Item	Description
<b>Color Mode</b>	<p>You can select the default color mode to use for copy jobs.</p> <ul style="list-style-type: none"> <li>• <b>Auto:</b> Select this setting to automatically detect whether the scanned document is in color or black and white, and then select an appropriate color setting.</li> <li>• <b>Color:</b> Select this setting to print the same as the original image color.</li> <li>• <b>Mono:</b> Select this setting to print the copy in black and white, regardless whether the scanned document is in color or in black and white.</li> </ul>
<b>Paper Source</b>	<p>Allows you to check the current tray settings and change the settings if necessary.</p> <div style="border: 1px solid #ccc; padding: 10px; margin: 10px 0;">  <p><b>Auto:</b> You can set the machine to automatically to the tray with the same sized paper when the tray in use is empty.</p> </div>
<b>Stamp</b>	<p>You can apply the stamp feature.</p> <ul style="list-style-type: none"> <li>• <b>Item:</b> Prints the time and date, IP address, page number, device information, comment, or user ID, to the copy output.</li> <li>• <b>Text Size:</b> You can select the text size.</li> <li>• <b>Opacity:</b> You can select the transparency.</li> <li>• <b>Position:</b> Sets the position.</li> </ul>

Item	Description
<b>Layout</b>	Adjusts the layout format such as ID copy, 2/4-up, etc.
<b>ID Copy</b>	This feature is helpful for copying a small-sized item such as business card (see "ID card copying" on page 67).
<b>Basic Copy</b>	Copies can be started quickly.
<b>Custom Copy</b>	Copies can be customized through detailed options.
<b>Auto Fit Copy</b>	Copies image to fit automatically to the paper size.
<ul style="list-style-type: none"> <li>• <b>Collation</b></li> <li>• <b>Collation Copy</b></li> </ul>	<p>Set the machine to sort the copy job. For example, if you make 2 copies of a 3 page original, one complete 3 page document will print followed by a second complete document.</p> <ul style="list-style-type: none"> <li>• <b>On:</b> Prints output in sets to match the sequence of originals.</li> </ul> <div style="text-align: center;">  </div> <ul style="list-style-type: none"> <li>• <b>Off:</b> Prints output sorted into stacks of individual pages.</li> </ul> <div style="text-align: center;">  </div>

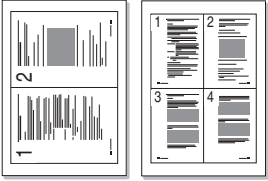
# Copy

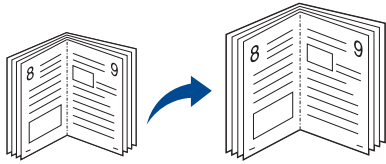
Item	Description
<ul style="list-style-type: none"><li>• <b>2-Up</b> or <b>4-Up</b></li><li>• <b>N-Up Copy</b></li></ul>	<p>Reduces the size of the original images and prints 2 or 4 pages onto one sheet of paper. You can select the orientation of the originals.</p> 



Item	Description
<b>Book Copy</b>	<p>The Book Copy feature allows you to copy an entire book. If the book is too thick, lift the cover until its hinges are caught by the stopper and then close the cover. If the book or magazine is thicker than 30 mm, start copying with the cover open.</p>  <ul style="list-style-type: none"><li>• <b>Left Page:</b> Use this option to print left page of the book.</li><li>• <b>Right Page:</b> Use this option to print right page of the book.</li><li>• <b>Both Page:</b> Use this option to print both pages of the book.</li></ul> <div style="border: 1px solid gray; padding: 5px;"> This copy feature is available only when you place originals on the scanner glass.</div>

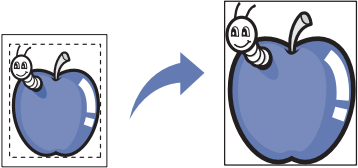

# Copy

Item	Description
<b>Adjust Background</b>	<p>Prints an image without its background. This copy feature removes the background color and can be helpful when copying an original containing color in the background, such as a newspaper or a catalog.</p> <ul style="list-style-type: none"><li>• <b>Off:</b> Does not use this feature.</li><li>• <b>Auto:</b> Optimizes the background.</li><li>• <b>Enhance Lev.1~2:</b> The higher the number is, the more vivid the background is.</li><li>• <b>Erase Lev.1~4:</b> The higher the number is, the lighter the background is.</li></ul>

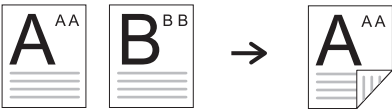
Item	Description
<b>Edge Erase</b>	<p>Allows you to erase spots, drill holes, fold creases and staple marks along any of the four edges of a document.</p>  <ul style="list-style-type: none"><li>• <b>Off:</b> Does not use this feature.</li><li>• <b>Small Original:</b> raises the edge of the original if it is small. This feature is available only when you place originals on the scanner glass.</li><li>• <b>Hole Punch:</b> Erases the marks of bookbinding holes.</li><li>• <b>Book Center:</b> Erases the middle part of the paper which is black and horizontal, when you copy a book. This feature is available only when you place originals on the scanner glass.</li><li>• <b>Border Erase:</b> Enter the left, right, top, bottom margin using Number keypad.</li></ul>

# Copy

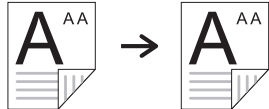
Item	Description
<b>Watermark</b>	<p>The watermark option allows you to print text over an existing document. For example, you use it when you want to have large gray letters reading "DRAFT" or "CONFIDENTIAL" printed diagonally across the first page or all pages of a document.</p> 
<b>Duplex</b>	<p>You can set the machine to print copies on both sides of paper.</p> <ul style="list-style-type: none"> <li>• <b>1-&gt;1 Sided:</b> Scans one side of an original and prints it on one side of the paper.</li> <li>• <b>1-&gt;2 Sided</b>  </li> <li>• <b>1-&gt;2 Sided, Rotated</b>  </li> </ul>

Item	Description
<b>Duplex (continue)</b>	<ul style="list-style-type: none"> <li>• <b>2-&gt;1 Sided</b>  </li> <li>• <b>2-&gt;2 Sided</b>  </li> <li>• <b>2-&gt;1 Sided, Rotated</b>  </li> </ul>
<b>Program</b>	<p>This option allows you to save the current settings for future use. You can also use the previous settings from the last jobs.</p> <ul style="list-style-type: none"> <li>• <b>Save Program</b></li> <li>• <b>Load Program</b></li> </ul>

# Copy

## Copy Setup



Some menus may not appear in the display depending on options or models. If so, it is not applicable to your machine (see "Menu overview" on page 28).

To change the menu options:

Press  (**Menu**) > **Copy Setup** on the control panel.

Item	Description
<b>Change Default</b>	The copy options can be set to those most frequently used.



# Fax



- This function is not supported for C306xND
- Some menus may not appear in the display depending on options or models. If so, it is not applicable to your machine (see "Menu overview" on page 28).

To change the menu options:

- Press (**Setup**) > **Machine Setup** > **Next** > **Default Setting** > **Fax Default** on the touch screen.
- Or press (**Fax**) > select the menu item you want on the touch screen.
- Or press (**Setup**) > **Machine Setup** > **Next** > **Fax Setup** on the touch screen.

Item	Description
<b>Original Size</b>	Sets the image size.
<b>Original Type</b>	Enhances the fax quality based on the type of the original document being scanned.
<b>Darkness</b>	Adjusts the brightness level to scan an original that is easier to read, when the original contains faint markings and dark images (see "Darkness" on page 73).

Item	Description
<b>Resolution</b>	The default document settings produce good results when using typical text-based originals. However, if you send originals that are of poor quality, or contain photographs, you can adjust the resolution to produce a higher quality fax (see "Resolution" on page 72).
<b>Color Mode</b>	Selects the color mode in which you want to send the fax. <ul style="list-style-type: none"> <li>• <b>Mono:</b> Transmits a fax in black and white.</li> <li>• <b>Color:</b> Transmits a fax in color.</li> </ul>
<b>Duplex</b>	This function is especially intended for two-sided originals. You can select whether the machine sends the fax on one side or both sides of the paper. <ul style="list-style-type: none"> <li>• <b>1 Sided:</b> For originals that are printed on one side only.</li> <li>• <b>2 Sided:</b> For originals that are printed on both sides.</li> <li>• <b>2 Sided Rotated:</b> For originals that are printed on both sides, but the back is rotated 180 degrees.</li> </ul> <div style="border: 1px solid gray; padding: 5px; margin-top: 10px;">  To use <b>2 Sided</b> and <b>2 Sided, Rotated</b>, load the originals on the DADF. If the machine cannot detect the original on the DADF, it automatically changes the option to <b>1 Sided</b>.         </div>
<b>Memory Send</b>	Fax can be customized through detailed options.

# Fax

Item	Description
<b>On Hook Dial</b>	Access a dial tone to send fax.
<b>Speed Dial Send</b>	Fax image to destination from speed dial list.
<b>Group Dial Send</b>	Fax image to destination from group dial list.
<b>Redial</b>	Redials the recently sent fax number or received caller ID in ready mode, or inserts a pause(-) into a fax number in edit mode (see "Redialing the fax number" on page 286).
<b>Delayed Send</b>	<p>Sets your machine to send a fax at a later time when you will not be present (see "Delaying a fax transmission" on page 287).</p> <div style="border: 1px solid #ccc; background-color: #f9f9f9; padding: 5px; margin-top: 10px;">  You cannot send a color fax using this feature.         </div>
<b>Send Forward</b> <b>Receive Forward</b>	<p>Forwards the received or sent fax to other destination by a fax or PC. If you are out of office but have to receive the fax, this feature may be useful.</p> <ul style="list-style-type: none"> <li>• See "Forwarding a sent fax to another destination" on page 288.</li> <li>• See "Forwarding a received fax" on page 289.</li> </ul>

Item	Description
<b>Secure Receive</b>	Stores the received fax in memory without printing out. To print received documents, you need to enter the password. You can prevent your received faxes from being accessed by unauthorized people (see "Receiving in secure receiving mode" on page 292).
<b>Redial Times</b>	Sets the number of redial attempts. If you enter 0, the machine will not redial.
<b>Redial Term</b>	Sets the time interval before automatic redialling.
<b>Prefix Dial</b>	Sets a prefix of up to five digits. This number dials before any automatic dial number is started. It is useful for accessing a PABX exchange.
<b>ECM Mode</b>	Sends faxes using error correction mode (ECM) to makes sure the faxes are sent smoothly without any error. It may take more time.
<b>Fax Confirmation</b>	<p>Sets the machine to print a report whether a fax transmission was successfully completed or not.</p> <div style="border: 1px solid #ccc; background-color: #f9f9f9; padding: 5px; margin-top: 10px;">  If you select <b>On-Error</b>, the machine prints a report only when a transmission is not successful.         </div>
<b>Modem Speed</b>	Select the maximum modem speed you want if the phone line fails to sustain a higher modem speed. You can select 33.6, 28.8, 14.4, 12.0, 9.6 or 4.8 kbps.

# Fax

Item	Description
<b>Image TCR</b>	Prints a transmission report with a minimized image of the first page of the fax sent.
<b>Dial Mode</b>	Sets the dialing mode to either tone or pulse. This setting may not be available depending on your country.
<b>Toll Save</b>	Sends faxes at a preset toll-saving time to save on call costs.
<b>Junk Fax Setup</b>	Using this feature, the system will not accept faxes sent from remote stations whose numbers are stored in the memory as junk fax numbers. This feature is useful for blocking any unwanted faxes.  When you turn on this feature, you can access the following options to set junk fax numbers.
<b>Fax Setup Wizard</b>	Makes it easy to configure the necessary fax options such as machine ID, fax number, etc.
<b>Receive Mode</b>	Selects the default fax receiving mode (see "Changing the receive modes" on page 290).
<b>Ring to Answer</b>	Specifies the number of times the machine rings before answering an incoming call.
<b>Stamp Received Name</b>	Automatically prints the page number, and the date and time of reception at the bottom of each page of a received fax.

Item	Description
<b>Receive Start Code</b>	Initiates fax reception from an extension phone plugged into the EXT socket on the back of the machine. If you pick up the extension phone and hear fax tones, enter the code. It is preset to *9* at the factory.
<b>Auto Reduction</b>	Automatically reduces an incoming fax page to fit the size of the paper loaded in the machine.
<b>Discard Size</b>	Discards a specific length from the end of the received fax.
<b>DRPD Mode</b>	Enables a user to use a single telephone line to answer several different telephone numbers. You can set the machine to recognize different ring patterns for each number. This setting may not be available depending on your country (see "Receiving faxes using DRPD mode" on page 292).
<b>Duplex Print</b>	Prints the received fax data on both sides of the paper. You can save the paper usage. <ul style="list-style-type: none"><li>• <b>Off:</b> Prints only one side of the paper.</li><li>• <b>Long Edge:</b> Prints both sides of the paper; however, the binding will be the long edge.</li><li>• <b>Short Edge:</b> Prints both sides of the paper; however, the binding will be the short edge.</li></ul>
<b>Smart Fax Diagnostics</b>	The Smart Fax feature optimizes the settings for your fax line.

# Fax





Item	Description
<b>TX/RX Report</b>	You can set the machine to print a report with detailed information about the previous 50 communication operations, including time and dates.
<b>Paper Source</b>	<p>Allows you to check the current tray settings and change the settings if necessary.</p> <div data-bbox="383 547 1081 743"> <b>Auto:</b> You can set the machine to automatically to the tray with the same sized paper when the tray in use is empty.</div>

# Scan



Some menus may not appear in the display depending on options or models. If so, it is not applicable to your machine (see "Menu overview" on page 28).

To change the menu options:

- Press  (**Menu**) > **Scan Feature** or **Scan Setup** on the control panel.  
Or **Scan to** >  (**Menu**) > **Scan Feature** or **Scan Setup** on the control panel.
- Or press  (**Setup**) > **Machine Setup** > **Next** > **Default Setting** > **Scan Default** on the touch screen.
- Or press  (**Scan**) > select the menu item you want on the touch screen.

Item	Description
<ul style="list-style-type: none"> <li>• <b>USB</b></li> <li>• <b>USB Feature</b></li> </ul>	Sets scan destination to a USB. You scan the originals and save the scanned image to a USB device.
<ul style="list-style-type: none"> <li>• <b>Email</b></li> <li>• <b>Custom Email</b></li> <li>• <b>Email Feature</b></li> </ul>	Sets scan destination to an email. You scan the originals and email the scanned image to destinations (see "Scanning to email" on page 279).
<ul style="list-style-type: none"> <li>• <b>FTP Feature</b></li> <li>• <b>FTP</b></li> </ul>	Sets scan destination to an FTP server. You scan the originals and send the scanned image to an FTP server (see "Scanning to FTP/SMB server" on page 280).

Item	Description
<ul style="list-style-type: none"> <li>• <b>SMB</b></li> <li>• <b>SMB Feature</b></li> </ul>	Sets scan destination to an SMB server. You scan the originals and send the scanned image to an SMB server (see "Scanning to FTP/SMB server" on page 280).
<b>Local PC</b>	Sets scan destination to a usb-connected computer. You scan the originals and save the scanned image to a directory such as <b>My Documents</b> (see "Basic Scanning" on page 69).
<b>Network PC</b>	Sets scan destination to a network-connected computer. You scan the originals and save the scanned image to a directory such as <b>My Documents</b> (see "Scanning from network connected machine" on page 278).
<b>WSD</b>	Scans the originals and saves the scanned data on the connected computer if it supports the WSD (Web Service for Device) feature.
<b>Shared Folder</b>	Sets scan destination to a shared folder. You can create and use the shared folder (see "Using shared folder features" on page 293).
<b>Samsung Cloud</b>	You can scan an image and the scanned data will be stored in the cloud service.



# Scan

Item	Description
<b>File Format</b>	<p>Sets the file format in which the image is to be saved. If you select JPEG, TIFF, XPS or PDF, you can select to scan multiple pages. Depending on the selected scan type, this option may not appear.</p> <ul style="list-style-type: none"><li>• <b>Single-Page TIFF:</b> Scans the originals in TIFF (Tagged Image File Format), and several originals are scanned as an each individual TIFF file.</li><li>• <b>Multi-Page TIFF:</b> Scans originals in TIFF (Tagged Image File Format), but several originals are scanned as one file.</li><li>• <b>Single-Page PDF:</b> Scans the originals in PDF, and several originals are scanned as an each individual TIFF file.</li><li>• <b>Multi-Page PDF:</b> Scans originals in PDF, but several originals are scanned as one file.</li><li>• <b>Single-Page XPS:</b> Scans the originals in XPS, and several originals are scanned as an each individual TIFF file.</li><li>• <b>Multi-Page XPS:</b> Scans originals in XPS, but several originals are scanned as one file.</li><li>• <b>JPEG:</b> Scans original in JPEG format.</li></ul> <div style="border: 1px solid #ccc; padding: 5px; margin-top: 10px;"><ul style="list-style-type: none"><li>•  <b>XPS:</b> This feature is only supported for the devices that have mass storage.</li><li>• The file format <b>JPEG</b> cannot be selected in the File Format option, if <b>Mono</b> has been selected for <b>Color Mode</b>.</li></ul></div>

Item	Description
<b>Destination</b>	Enter the destination's information.
<b>Change Default</b>	The scan options can be set to those most frequently used.
<b>Original Size</b>	Sets the image size.
<b>Original Type</b>	Sets the original document's type.
<b>Resolution</b>	Sets the image resolution.
<b>Color Mode</b>	<p>You can select the color options of scan outputs.</p> <ul style="list-style-type: none"><li>• <b>Color:</b> Uses color to display an image. 24 bits per pixel, 8 bits for each RGB, is used for 1 pixel.</li><li>• <b>Gray:</b> Uses the black gradation to display an image. 8 bits per pixel.</li><li>• <b>Mono:</b> Displays an image in black and white. 1 bit per pixel.</li></ul>
<b>Darkness</b>	Adjusts the brightness level to scan.

# Scan

Item	Description
<b>Duplex</b>	<p>Selects if the machine scans one side of the paper (1 Sided), both sides of the paper (2 Sided), or both sides of the paper (2 Sided Rotated).</p> <ul style="list-style-type: none"> <li>• <b>1 Sided:</b> For originals that are printed on one side only.</li> <li>• <b>2 Sided:</b> For originals that are printed on both sides.</li> <li>• <b>2 Sided Rotated:</b> For originals that are printed on both sides, but the back is rotated 180 degrees.</li> </ul> <div style="border: 1px solid #ccc; padding: 5px; margin-top: 10px;">  If an original is placed on the scanner glass, the machine shows the window asking to place another page. Load another original and press Yes. When you finish, select No for this option.         </div>
<b>Filing Policy</b>	<p>You can choose the policy for generating file name before you proceed with the scan job through server or USB memory device. If the server or the USB memory device already has the same name you enter, you can change the name, cancel the job, or overwrite it.</p> <ul style="list-style-type: none"> <li>• <b>Change Name:</b> The sent file is saved as a different file name that is automatically programmed.</li> <li>• <b>Overwrite:</b> Overwrites the existing the file.</li> <li>• <b>Cancel:</b> Does not save the sent file.</li> </ul>
<b>File Name</b>	Makes a file name to store the scan data.

Item	Description
<b>Server Confirmation</b>	<p>You can set the machine to print server confirmation result report.</p> <div style="border: 1px solid #ccc; padding: 5px; margin-top: 10px;">  If you select <b>On-Error</b>, the machine prints a report only when a transmission is not successful.         </div>
<b>Email Confirmation</b>	<p>You can set the machine to print email confirmation result report.</p> <div style="border: 1px solid #ccc; padding: 5px; margin-top: 10px;">  <ul style="list-style-type: none"> <li>• If you select <b>On-Error</b>, the machine prints a report only when a transmission is not successful.</li> <li>• If a report contains characters or fonts that the machine does not support, <b>Unknown</b> could be printed instead of the characters/fonts in the report.</li> </ul> </div>
<b>Page Separation</b>	Specifies the number of pages to include in each file when you save the scanned document in separate files.
<b>PDF Encryption</b>	Encrypts the PDF files when you scan the originals in PDF format. Select <b>On</b> to encrypt the PDF file, and set up a password. To open the file, users need to enter the password

# Scan

Item	Description
<b>Digital Signature in PDF</b>	Digital signature the PDF files when you scan the originals in PDF format. Select <b>On</b> to digital signature in PDF file, and set up a digital signature. To open the file, users need to enter the digital signature.
<b>Subject</b>	Sets an email's subject.
<b>To</b>	Sets the recipient's email address.
<b>From</b>	Sets a sender's email address.
<b>CC</b>	Sends the copy of the email to an additional recipient.
<b>BCC</b>	The same as <b>CC</b> but the recipient's name is not displayed.
<b>Program</b> <ul style="list-style-type: none"><li>• <b>Save Program</b></li><li>• <b>Load Program</b></li></ul>	This option allows you to save the current settings for future use. You can also use the previous settings from the last jobs.
<b>Country Code</b>	Enter the country code.
<b>Phone Number</b>	Enter your registered phone number of Samsung cloud.
<b>Sender Information</b>	Enter the sender information.





# System setup

## Machine setup



Some menus may not appear in the display depending on options or models. If so, it is not applicable to your machine (see "Menu overview" on page 28).

To change the menu options:

- Press  (**Menu**) > **System Setup** > **Machine Setup** on the control panel.
- Or press  (**Setup**) > **Machine Setup** > **Next** > **Initial Setup** on the touch screen.
- Or press  (**Setup**) > **Machine Setup** > select the menu item you want on the touch screen.

Item	Description
<b>Machine ID</b>	Sets the machine ID which will be printed at the top of each fax page that you send.
<b>Machine ID &amp; Fax Number</b>	Sets the machine ID and fax number which will be printed at the top of each fax page that you send.
<b>Date &amp; Time</b>	Sets the date and time.
<b>Clock Mode</b>	Selects the format for displaying time between 12 hr. and 24 hr.

Item	Description
<b>Language</b>	Sets the language of the text that appears on the control panel display.
<b>Default Mode</b>	Sets the machine's default mode among fax mode, copy mode, or scan mode.
<b>Power Save</b>	Sets how long the machine waits before going to power save mode.  When the machine does not receive data for an extended period of time, power consumption is automatically lowered.
<b>Wakeup Event</b>	When this option is " <b>On</b> ", you can wake up the machine from the power saving mode with the following actions: <ul style="list-style-type: none"><li>• pressing any button on the control panel</li><li>• loading paper in a tray</li><li>• opening or closing the front cover</li><li>• pulling a tray out or pushing a tray in</li><li>• connecting a USB memory device (only for the models that support USB memory devices)</li></ul> <div data-bbox="1473 1155 2190 1394"> If the machine does not have the touch screen, you can wake up the machine from the power saving mode by pressing any button on the control panel regardless of this option's setting.</div>

# System setup

Item	Description
<b>System Timeout</b>	Sets the time that the machine remembers previously used copy settings. After the timeout, the machine restores the default copy settings.
<b>Job Timeout</b>	Sets the length of time the printer waits before printing the last page of a print job that does not end with a command to print the page.
<b>Held Job Timeout</b>	When an error occurs while printing and there is no signal from the computer, the machine holds a job for a specific time period before deleting it.
<b>Altitude Adjustment</b>	Optimize print quality according to the machine's altitude.
<b>Receive Mode</b>	Selects the default fax receiving mode.
<b>Receive code</b>	This feature works best when you are using an extension telephone connected to the EXT socket on the back of your machine. You can receive a fax from someone you are talking to on the extension telephone, without going to the fax machine. *9* is the remote receive code preset at the factory (see "Receiving faxes with an extension telephone" on page 291).
<b>Select Country</b>	Selects the country.
<b>Sound/Volume</b>	Sets the sound/volume option.
<b>Toner Low Alert</b>	If toner in the cartridge has run out, a message informing the user to change the toner cartridge appears. You can set the option for this message to appear or not.

Item	Description
<b>Image Overwrite</b>	<p>You can set the machine to overwrite data stored in the memory. The machine overwrites the data with different patterns eliminating the possibilities of recovery.</p> <ul style="list-style-type: none"><li>• <b>Manual:</b> When printing, copying, scanning, and faxing, the machine temporarily uses memory space. For security reasons, you can set the machine to manually overwrite secure non-volatile memory. If you want to secure memory space, you can manually overwrite secure non-volatile memory.</li><li>• <b>Automatic:</b> When a job is completed, there are temporary images left in the memory. For security reasons, you can set the machine to automatically overwrite secure non-volatile memory. If you want to secure memory space, you can set the machine to automatically overwrite secure non-volatile memory.</li></ul>
<b>Default Paper Size</b>	You can set the default paper size to use.
<b>Humidity</b>	Optimizes print quality according to the humidity in the environment.
<b>Job Rescheduling</b>	<b>Job Rescheduling</b> allows the machine to proceed to the next job when the current job pauses due to a paper mismatch or paper empty error.

# System setup

Item	Description
<b>Auto Continue</b>	<p>Determine whether or not the machine continues printing when it detects the paper does not match the paper settings.</p> <ul style="list-style-type: none"> <li>• <b>0 Sec:</b> This option allows you to continue printing when the paper size you have set is mismatched with the paper in the tray.</li> <li>• <b>30 Sec:</b> If a paper mismatch occurs, an error message will display. The machine waits for about 30 second, then automatically clear the message and continue printing.</li> <li>• <b>Off:</b> If a paper mismatch occurs, the machine waits until you insert the correct paper.</li> </ul>
<b>Auto CR</b>	Allows you to append the required carriage return to each line feed, which is useful for Unix or DOS users.
<b>Firmware Version</b>	Shows the product's firmware version.
<b>Auto Tray Switch</b>	<p>Determine whether or not the machine continues printing when it detects the paper does not match. For example, if both tray 1 and tray 2 are filled with the same size paper, the machine automatically prints from tray 2 after the tray 1 runs out of paper.</p> <div style="border: 1px solid #ccc; padding: 5px; margin-top: 10px;">  This option does not appear if you selected <b>Auto</b> for <b>Paper Source</b> from printer driver.         </div>

Item	Description
<b>Paper Substitution</b>	Automatically substitutes the printer driver's paper size to prevent the paper mismatch between Letter and A4. For example, if you have A4 paper in the tray but you set the paper size to Letter in the printer driver, the machine prints on A4 paper and vice versa.
<b>Skip Blank Pages</b>	The printer detects the printing data from computer whether a page is empty or not. You can set to print or skip the blank page.
<b>Tray Protection</b>	<p>Decides to use or not use the <b>Auto tray switch</b> feature.</p> <p>If you set tray 1 to <b>On</b>, for example, then tray 1 is excluded during tray switching.</p> <div style="border: 1px solid #ccc; padding: 5px; margin-top: 10px;">  This setting works for copy or print jobs: It doesn't affect fax jobs.         </div>



# System setup

Item	Description
<b>Tray Mode</b>	<p>Specifies whether or not the machine automatically changes the paper settings to the required settings when you close the tray.</p> <ul style="list-style-type: none"><li>• <b>Static:</b> The tray settings do not change when you open and close the tray.</li><li>• <b>Dynamic:</b> If you open and close the tray when a paper mismatch occurs, the paper settings (size and type) for that tray automatically change to the settings required for the job. (When you open and close the tray in the <b>Dynamic</b> mode, the machine presumes that the paper in the tray was replaced with the size and type required for the job.)</li></ul>
<b>PDF Type</b>	<p>Allows you to select the PDF type when saving the data as a PDF file.</p> <ul style="list-style-type: none"><li>• <b>Standard:</b> Saves the data as a regular PDF.</li><li>• <b>PDF/A:</b> Saves the data as a PDF that has the necessary information to render itself in any environment.</li></ul> <div> PDF/A file must be self-contained: it cannot rely on another application to render fonts, open hyperlinks, or execute scripts, audio files, or video files.</div>

Item	Description
<b>Stamp</b>	<p>You can apply the stamp feature.</p> <ul style="list-style-type: none"><li>• <b>Item:</b> Prints the time and date, IP address, page number, device information, or user ID, to the copy output.</li><li>• <b>Opacity:</b> You can select the transparency.</li><li>• <b>Position:</b> Sets the position.</li></ul>
<b>Address Book</b>	<p>Views or prints the phone book or email address list.</p>
<b>Import Setting</b>	<p>Imports data stored on a USB memory stick to the machine.</p>
<b>Export Setting</b>	<p>Exports data stored on the machine stick to a USB memory.</p>
<b>CLR Empty Msg</b>	<p>When toner cartridge is empty, this option appears. You can clear the empty message.</p>

# System setup

Item	Description
<b>Eco Settings</b>	<p>Allows you to save print resources and enables eco-friendly printing.</p> <ul style="list-style-type: none"> <li>• <b>Default Mode:</b> Select whether to turn the eco mode on or off.</li> </ul> <div style="border: 1px solid #ccc; padding: 5px; margin: 10px 0;">  <b>On force (On-Forced):</b> Sets the eco mode on with password. If a user wants to turn the eco mode on/off, the user needs to enter the password.         </div> <ul style="list-style-type: none"> <li>• <b>Select Template:</b> Selects the eco template set from the SyncThru™ Web Service.</li> </ul>
<b>Vapor Mode</b>	<p>You can reduce the amount of water vapor produced during printing.</p> <ul style="list-style-type: none"> <li>• <b>Off:</b> Disables vapor mode.</li> <li>• <b>On:</b> Enables vapor mode.</li> <li>• <b>Auto:</b> Automatically enters vapor mode according to time in high humidity environments.</li> </ul>

Item	Description
<b>Auto Power Off</b>	<p>Turns power off automatically when the machine has been in power save mode for the length of time set in <b>Auto Power Off &gt; On &gt; Timeout</b>.</p> <div style="border: 1px solid #ccc; padding: 5px; margin: 10px 0;">  <ul style="list-style-type: none"> <li>• To turn the machine on again, press the  (<b>Power/Wakeup</b>) button on the control panel (make sure the main power switch is on).</li> <li>• If you run the printer driver or <b>Samsung Easy Printer Manager</b>, the time automatically extends.</li> <li>• While the machine is connected to the network or working on a print job, <b>Auto Power Off</b> feature doesn't work.</li> </ul> </div>
<b>Image Management</b>	<p>Allows you to adjust the color setting such as color registration, color density, etc.</p>
<b>Custom Color</b>	<p>This menu allows you to adjust contrast, color by color.</p> <ul style="list-style-type: none"> <li>• <b>Default:</b> Optimizes colors automatically.</li> <li>• <b>Print Density:</b> Allows you to manually adjust the color density for print. Adjust the print density.</li> </ul> <p>It is recommended to use the <b>Default</b> setting for best color quality.</p>

# System setup

Item	Description
<ul style="list-style-type: none"> <li>• <b>Auto Color Reg.</b></li> <li>• <b>Auto Color Registration</b></li> </ul>	<p>The machine virtually prints certain patterned image to calibrate the color printing position. This feature enhances the colored image sharper and clearer, which means the machine prints the colored image on the paper more like the one in the monitor.</p> <div style="border: 1px solid #ccc; padding: 5px; margin-top: 10px;">  If you have moved the machine, it is strongly recommended to operate this menu manually.         </div>
<b>Tone Adjustment</b>	<ul style="list-style-type: none"> <li>• <b>Default:</b> The machine automatically calibrates the toner density of machine for the best possible color print quality. If you select Off, the machine is calibrated by the factory default toner density.</li> <li>• <b>Auto Tone Adjustment (Auto Tone Adj.):</b> Allows you to automatically adjust tone for the best possible print quality.</li> <li>• <b>Calibrating ID Sensor (Cal. ID Sensor):</b> Automatically calculates the reduced or worn out supplies like toner or machine parts and uses this information to adjust the color density. For example, if the yellow toner is running out, the machine calculates the amount of remaining yellow toner and adjusts color density so the printouts are fine.</li> </ul>

Item	Description
<b>Stacking Mode</b>	If you use a machine in a humid area, or you are using the damp print media caused by a high humidity, the print-outs on the output tray may be curled and may not be stacked properly. In this case, you can set the machine to use this function to let print-outs stacked firmly. But, using this function will make the print speed slow.
<b>Quiet Mode</b>	You can reduce the printing noise by turning this menu on. However, the printing speed and quality may be declined.
<b>Smart Duplex</b>	Uses simplex mode when printing only one original page or a blank page although the duplex option is enabled.
<b>Logout Confirmation</b>	Determines whether to use the confirmation pop-up when you log out.



# System setup

## Paper setup



Some menus may not appear in the display depending on options or models. If so, it is not applicable to your machine (see "Menu overview" on page 28).

To change the menu options:

- Press  (**Menu**) > **System Setup** > **Paper Setup** on the control panel.
- Or press  (**Setup**) > **Machine Setup** > **Next** > **Paper Setup** on the touch screen.

Item	Description
<b>Paper Size</b>	Sets the paper size as A4, Letter, or other paper sizes, according to your requirements.
<b>Paper Type</b>	Chooses the type of the paper for each tray.
<b>Paper Source</b>	Selects from which tray the paper is used.
<b>Margin</b>	Sets the margins for the document.

Item	Description
<b>Common Margin</b>	<ul style="list-style-type: none"><li>• <b>Simplex Margin:</b> Sets the margin for one-sided printing.</li><li>• <b>Duplex Margin:</b> Sets the margin for double-sided printing.</li><li>• <b>Binding:</b> When printing on both sides of the paper, side A's margin closest to the binding will be the same as side B's margin closest to the binding. Likewise, the sides' margins farthest from the binding will be the same.</li><li>• <b>Top Margin:</b> Sets the top margin.</li><li>• <b>Left Margin:</b> Sets the left margin.</li></ul>
<b>Emulation Margin</b>	Sets the paper margins for emulation print page. <ul style="list-style-type: none"><li>• <b>Top Margin:</b> Sets the top margin.</li><li>• <b>Left Margin:</b> Sets the left margin.</li></ul>
<b>MP Tray</b>	Sets the paper margins in multi-purpose tray. <ul style="list-style-type: none"><li>• <b>Simplex Margin:</b> Sets the margin for one-sided printing.</li><li>• <b>Duplex Margin:</b> Sets the margins for double-sided printing.</li><li>• <b>Top Margin:</b> Sets the top margin.</li><li>• <b>Left Margin:</b> Sets the left margin.</li></ul>

# System setup

Item	Description
<b>Tray Confirmation</b>	Activates the tray confirmation message. If you open and close a tray, a window opens asking you confirm the paper size and type. This message can be turned off if found to be annoying.
<Tray X>	Sets the paper margins for the paper trays. <ul style="list-style-type: none"><li>• <b>Simplex Margin:</b> Sets the margin for one-sided printing.</li><li>• <b>Duplex Margin:</b> Sets the margins for double-sided printing.</li><li>• <b>Top Margin:</b> Sets the top margin.</li><li>• <b>Left Margin:</b> Sets the left margin.</li></ul>

## Sound / Volume



Some menus may not appear in the display depending on options or models. If so, it is not applicable to your machine (see "Menu overview" on page 28).

To change the menu options:

Press  **(Setup) > Machine Setup > Next > Initial Setup > Sound/Volume** on the touch screen.

Item	Description
<b>Key Sound</b>	Turns the key sound on or off. A tone sounds each time a key is pressed if this option is on.
<b>Alarm Sound</b>	Turns the alarm sound on or off. An alarm tone sounds when an error occurs or fax communication ends if this option is on.
<b>Fax Sound</b>	Allows you to adjust the sound volume for when pressing the button <ul style="list-style-type: none"><li>• <b>Speaker Volume:</b> Turns on or off the sounds from the telephone line through the speaker, such as a dial tone or a fax tone. With this option set to <b>Comm.</b> which means the speaker is on until the remote machine answers.</li><li>• <b>Dial Tone Volume:</b> Adjusts the dial tone volume. You can select different levels.</li><li>• <b>Ring Volume:</b> Adjusts the ring volume. You can select different levels.</li></ul>





# System setup

## Report



Some menus may not appear in the display depending on options or models. If so, it is not applicable to your machine (see "Menu overview" on page 28).

To change the menu options:

- Press  (**Menu**) > **System Setup** > **Report** on the control panel.
- Or press  (**Setup**) > **Machine Setup** > **Next** > **Reports** on the touch screen.

Item	Description
<b>Configuration</b>	Prints a report on the machine's overall configuration.
<b>Supplies Information</b>	Prints supplies' information page.
<b>Address Book</b>	Prints all of the email addresses currently stored in the machine's memory.
<b>Demo Page</b>	Prints the demo page to check whether your machine is printing properly or not.
<b>Fax Send Confirmation</b>	Prints fax confirmation result.

Item	Description
<b>Fax Sent</b>	Prints information on the faxes you have recently sent.
<b>Fax Received</b>	Prints information on the faxes you have recently received.
<b>Email Sent</b>	Prints information on the emails you have recently sent.
<b>Fax Scheduled Jobs</b>	Prints the document list currently stored for delayed faxes along with the starting time and type of each operation.
<b>Network Configuration</b>	Prints information on your machine's network connection and configuration.
<b>PCL Font</b>	Prints the PCL font list.
<b>PS Font</b>	Prints the PS/PS3 font list.
<b>Usage Counter</b>	Prints a usage page. The usage page contains the total number of pages printed.
<b>Account</b>	This is only available when Job Accounting is enabled from the SyncThru™ Web Admin Service. You can print a report of printout counts for each user.
<b>Help List</b>	Prints the help page to check whether your machine is printing properly or not.
<b>Junk Fax</b>	Prints the junk fax numbers.

# System setup

## Maintenance



Some menus may not appear in the display depending on options or models. If so, it is not applicable to your machine (see "Menu overview" on page 28).

To change the menu options:

Press  (**Menu**) > **System Setup** > **Maintenance** on the control panel.

Item	Description
<b>CLR Empty Msg.</b>	When toner cartridge is empty, this option appears. You can clear the empty message.
<b>Supplies Life</b>	Shows the supply life indicators (see "Monitoring the supplies life" on page 96.)
<b>Image Management</b>	Allows you to adjust the color setting such as color registration, color density, etc.
<b>Serial Number</b>	Shows the machine's serial number. When you call for service or register as a user on the Samsung website, you can find this.
<b>RAM Disk</b>	Enables/disables Ram disk to manage jobs.

## Job manage



Some menus may not appear in the display depending on options or models. If so, it is not applicable to your machine (see "Menu overview" on page 28).

To change the menu options:

Press  (**Menu**) > **Job Management** on the control panel.

Item	Description
<b>Active Job</b>	Shows the print job lists that are waiting to be printed.
<b>Stored Job</b>	Shows the print job lists that are stored on the disk.
<b>Secured Job</b>	Shows the print job lists that are secured on the disk.
<b>Shared Folder</b>	Shows the print job lists that are in the shared folder on the disk.

# System setup

## Address book setup



Some menus may not appear in the display depending on options or models. If so, it is not applicable to your machine (see "Menu overview" on page 28).

Press  (**Setup**) > **Machine Setup** > **Next** > **Address Book** on the touch screen.

Option	Description
<b>Individual</b>	You can create a individual.
<b>Group</b>	You can create a group.
<b>Print</b>	You can print the address book.
<b>Delete All</b>	You can delete the current all address book.



## Network setup





Some menus may not appear in the display depending on options or models. If so, it is not applicable to your machine (see "Menu overview" on page 28).



You can also use this feature from the SyncThru™ Web Service. Open the Web browser from your networked computer and type the IP address of your machine. When SyncThru™ Web Service opens, click **Settings** > **Network Settings** (see "SyncThru™ Web Service" on page 296).

- Press  (**Menu**) > **Network** on the control panel,
- Or press  (**Setup**) > **Machine Setup** > **Next** > **Network Setup** on the touch screen.

# System setup

Item	Description
<b>TCP/IP(IPv4)</b>	<p>Selects the appropriate protocol and configure parameters to use the network environment (see "Setting IP address" on page 164).</p> <p> There are many parameters to be set. If you are not sure, leave as is, or consult the network administrator.</p>
<b>TCP/IP(IPv6)</b>	<p>Selects this option to use the network environment through IPv6 (see "IPv6 configuration" on page 166).</p>
<b>Ethernet</b>	<p>Configure the network transmission speed or port.</p> <p> Turn the power off and on after you change this option.</p>
<b>802.1x</b>	<p>Select the user authentication for network communication. For detailed information consult the network administrator.</p>
<b>Wi-Fi</b>	<p>Selects this option to use the wireless network.</p>
<b>Clear Settings</b>	<p>Reverts the network settings to the default values.</p> <p> Turn the power off and on after you change this option.</p>

Item	Description
<b>Network Configuration</b>	<p>Displays information on your machine's network connection and configuration.</p>
<b>Ethernet Port</b>	<p>You can set whether to use Ethernet on or off.</p> <p> Turn the power off and on after you change this option.</p>
<b>Ethernet Speed</b>	<p>You can set the ethernet speed.</p>

# System setup

Item	Description
<b>Protocol Management</b>	<ul style="list-style-type: none"><li>• <b>WSD:</b> You can set WSD protocol.</li><li>• <b>HTTP:</b> You can set whether to use SyncThru™ Web Service or not.</li><li>• <b>Samsung Cloud Print:</b> You can set the <b>Samsung Clud Print</b> settings.</li><li>• <b>PrinterOn:</b> You can set the <b>PrinterOn</b> settings.</li><li>• <b>WINS:</b> You can configure the WINS server. WINS (Windows Internet Name Service) is used in the Windows operating system.</li><li>• <b>SNMPv1/v2:</b> You can set SNMP (Simple Network Management Protocol). Administrator's can use SNMP to monitor and manage machines on the network.</li><li>• <b>SNTP:</b> You can set SNTP (Simple Network Time Protocol) settings. SNTP synchronizes the clocks of the computer systems through the Internet (NTP) so there would not be a time difference when exchanging data.</li><li>• <b>UPnP(SSDP):</b> You can set UPnP protocol.</li><li>• <b>mDNS:</b> You can set mDNS (Multicast Domain Name System) settings.</li><li>• <b>SetIP:</b> You can set whether to use SyncThru™ Web Service or not.</li><li>• <b>SLP:</b> You can configure SLP (Service Location Protocol) settings. This protocol allows host applications to find services in a local area network without prior configuration.</li></ul> <div data-bbox="358 1348 1079 1503"> Turn the power off and on after you change this option.</div>

# Admin setup



Some menus may not appear in the display depending on options or models. If so, it is not applicable to your machine (see "Menu overview" on page 28).

To change the menu options:

- Press (**Menu**) > **Admin Setup** on the control panel.
- Or press (**Setup**) > **Admin Setup** > **Next** on the touch screen.

Item	Description
<b>User Access Control</b>	<p>You can control user access to a machine. You can assign different levels of permissions to use the machine to each user.</p> <p> You can also use this feature from the SyncThru™ Web Service. Open the Web browser from your networked computer and type the IP address of your machine. When SyncThru™ Web Service opens, click the <b>Security</b> tab &gt; <b>User Access Control</b> (see "Registering authorized users" on page 259).</p>
<b>Change Admin Password</b>	Changes the machine's password for accessing the <b>Admin Setup</b> .

Item	Description
<b>Firmware Upgrade</b>	To upgrade the latest firmware, turn this option " <b>On</b> " and then download the firmware file.
<b>Stamp</b>	Sets the stamp feature to access the Admin Setup menu.
<b>Image Overwrite</b>	<p>You can set the machine to overwrite data stored in the memory. The machine overwrites the data with different patterns eliminating the possibilities of recovery.</p> <ul style="list-style-type: none"><li>• <b>Manual Image Overwrite:</b> When printing, copying, scanning, and faxing, the machine temporarily uses memory space. For security reasons, you can set the machine to manually overwrite secure non-volatile memory. If you want to secure memory space, you can manually overwrite secure non-volatile memory. You can set the machine to repeat the manual image overwrite after the system is rebooted</li><li>• <b>Overwrite Method:</b> You can select the method for overwriting the secure non-volatile memory (hard disk).</li><li>• <b>Overwrite Times:</b> You can select the times for overwriting the secure non-volatile memory (hard disk).</li></ul>

# Admin setup

Item	Description
<b>Application</b>	<p>You can install or uninstall applications.</p> <ul style="list-style-type: none"><li>• <b>Application Management:</b> You can uninstall or enable/disable installed applications.</li><li>• <b>Install New Application:</b> You can install a new application from a USB.</li></ul>
<b>Secure Print</b>	<p>Sets the login method (ID and password, ID only, or PW only) for secure print jobs.</p>
<b>Coverage Counter</b>	<p>Displays the percentage of toner consumed by each class used in the printout. The usage amount for each class appears in the <b>Usage Counters</b> in the SyncThru™ Web Service. The printing area percentage is based on the ISO 5 % pattern that represents a standard document.</p>
<b>Import Setting</b>	<p>Imports data stored on a USB memory stick to the machine.</p>
<b>Export Setting</b>	<p>Exports data stored on the machine stick to a USB memory.</p>

Item	Description
<b>Supplies Management</b>	<p>Allows you to set options for supplies reorder notification. If you set this option, the machine will display a warning message when the supplies are running out. Prepare the supplies in advance.</p> <div><ul style="list-style-type: none"><li>• <b>Toner Low Alert:</b> If toner in the cartridge has run out, a message informing the user to change the toner cartridge appears. You can set the option for this message to appear or not.</li></ul></div>



Some menus may not appear in the display depending on options or models. If so, it is not applicable to your machine (see "Menu overview" on page 28).

To change the menu options:

Press  (**Eco**) > select the menu item you want on the touch screen.

Item	Description
<b>Eco-On or Off</b>	Select eco mode and change on/off or on-forced option.
<b>Settings</b>	Sets eco-related settings and change default settings. <ul style="list-style-type: none"><li>• <b>Default Mode:</b> Select this to turn on or off the default mode.</li><li>• <b>Feature Configuration:</b> Select the <b>Default</b> mode or <b>Custom</b> mode.</li></ul>



# Direct USB



Some menus may not appear in the display depending on options or models. If so, it is not applicable to your machine (see "Menu overview" on page 28).

To change the menu options:

Insert a USB memory device into the USB memory port on your machine.

- Press **Direct USB** on the control panel.
- or press  (**Direct USB**) > select the menu item you want on the touch screen.

Item	Description
<ul style="list-style-type: none"><li>• <b>USB Print</b></li><li>• <b>Print From</b></li></ul>	Select a file to print.
<b>Scan to USB</b>	Sets scan destination to a USB. You scan the originals and save the scanned image to a USB device.
<b>File Manage</b>	Select a file to delete. You can format the USB device.
<b>Check Space</b>	Shows the remaining space.

# Job Status



Some menus may not appear in the display depending on options or models. If so, it is not applicable to your machine (see "Menu overview" on page 28).

To change the menu options:

Press  (**Job Status**) > select the menu item you want on the touch screen.

Item	Description
<b>Current Job</b>	Displays the list of jobs in progress and pending.
<b>Completed Job</b>	Displays the list of completed jobs.

# Document box



Some menus may not appear in the display depending on options or models. If so, it is not applicable to your machine (see "Menu overview" on page 28).



Press  (**Document Box**) > select the menu item you want on the touch screen.

Item	Description
<b>System Boxes</b>	Saves the print data first and starts printing. <ul style="list-style-type: none"><li>• <b>Stored Print:</b> Prints the stored data without entering a password.</li><li>• <b>Secured Print:</b> Prints the stored data with entering a password.</li></ul>
<b>Shared Folder</b>	Show the shared folders on your network and save your scanned data there.



Some menus may not appear in the display depending on options or models. If so, it is not applicable to your machine (see "Menu overview" on page 28).

To change the menu options:

- Press  (**Menu**) > **PrinterOn** on the control panel.
- Or press  (**Setup**) > **Admin Setup** > **Next** on the touch screen.

You can enable the **PrinterOn** feature in the **PrinterOn** menu.



Before you can use the **PrinterOn** feature, you must configure the network connection of the machine. If you cannot connect to the machine after configuring its network connection, then you may have to check the external internet connection of the network.

When the **PrinterOn** feature is enabled, you can set it to **Release Code** mode or Auto mode. These modes can be changed on the **PrinterOn** server.

- **Release Code:** Users must enter a **Release Code** to print a document sent through **PrinterOn**.
- **Auto:** The machine automatically prints documents sent through **PrinterOn** without the user entering a **Release Code**.



# 4. Special Features

This chapter explains special copying, scanning, faxing, and printing features.

- **Altitude adjustment** 250
- **Storing email address** 251
- **Entering various characters** 253
- **Setting up the fax address book** 255
- **Registering authorized users** 259
- **Printing features** 260
- **Scan features** 277
- **Fax features** 286
- **Using shared folder features** 293

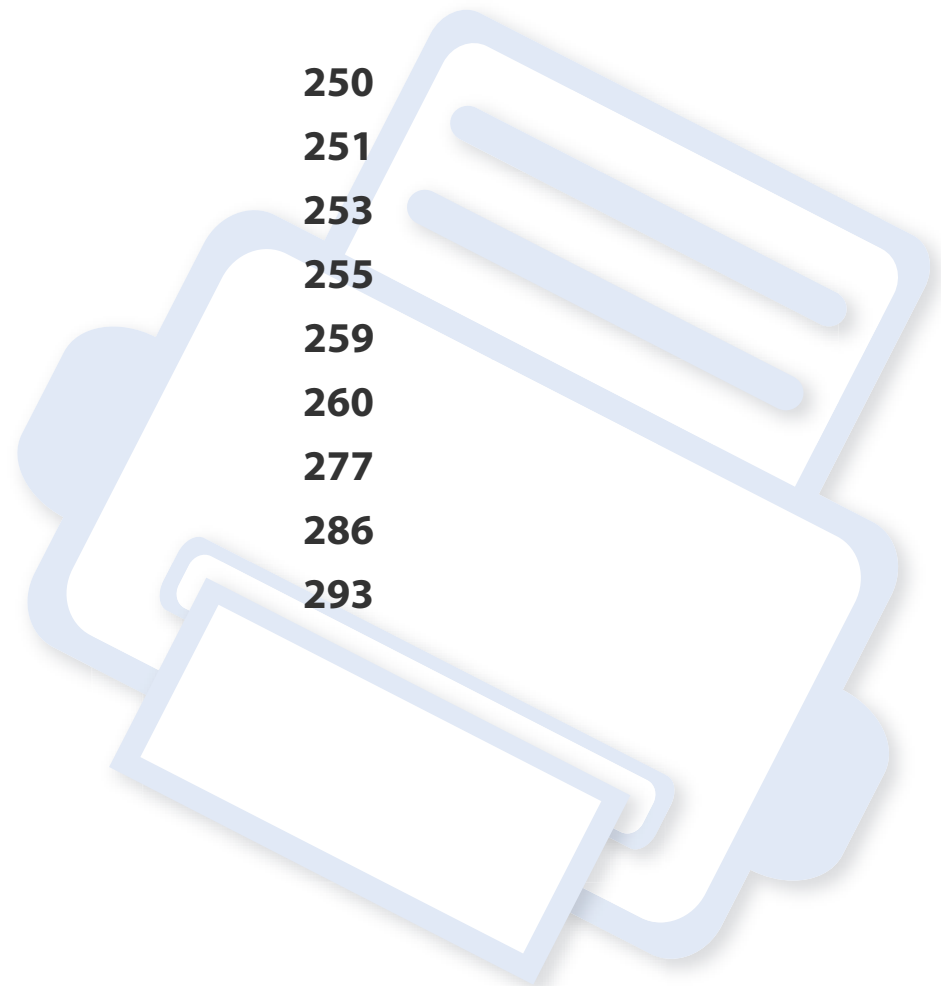

# Altitude adjustment

Print quality is affected by atmospheric pressure, which is determined by the height of the machine above sea level. The following information will guide you on how to set your machine for the best print quality.

Before you set the altitude value, determine the altitude where you are.

- **Normal:** 0-1,000 m(3,280 ft)
- **High1:** 1,000 m(3,280 ft)-2,000 m(6,561 ft)
- **High2:** 2,000 m(6,561 ft)-3,000 m(9,842 ft)
- **High3:** 3,000 m(9,842 ft)-4,000 m(13,123 ft)
- **High4:** 4,000 m(13,123 ft)-5,000 m(16,404 ft)

You can set the altitude value from Samsung Easy Printer Manager program or SyncThru™ Web Service.

- If your machine is connected to the local, you can set the machine's setting from **Samsung Easy Printer Manager > Advanced Setting > Device Settings** (see "Using Samsung Easy Printer Manager" on page 309).
- If your machine is connected to the network, you can set the machine's setting from **SyncThru™ Web Service > Settings tab > Machine Settings** (see "SyncThru™ Web Service" on page 296).



- If your machine is connected to the network, you can set the altitude via SyncThru™ Web Service (see "SyncThru™ Web Service" on page 296).
- You can also set the altitude in **System Setup** option on the machine's display (see "Machine's basic settings" on page 41).

# Storing email address



This feature may not be available depending on model or optional goods (see "Features by model" on page 7).

You can set up address book with the email addresses you use frequently via SyncThru™ Web Service and then easily and quickly enter email addresses by entering the location numbers assigned to them in address book.

## Storing on your machine

To scan and send an image as an email attachment, you need to set up email address using SyncThru™ Web Service.

- 1 Access the SyncThru™ Web Service (see "SyncThru™ Web Service" on page 296).
- 2 Click **Login** on the upper right of the SyncThru™ Web Service website.
- 3 Type in the **ID** and **Password** then click **Login**. We recommend you to change the default password for security reasons.
  - **ID: admin**
  - **Password: sec00000**
- 4 Click **Address Book > Individual > Add**.
- 5 Select the **Speed No.** and enter e-mail address and fax number.



If you need to set SMB or FTP sever information, check SMB or FTP and set the information.

- 6 Click **Apply**.



If you make a group,

- 1 Click **Address Book > Group > Add Group**.
- 2 Select the **Speed No.** and enter **Group Name**.  
You can easily add individual address if you check **Yes** for **Add individual(s) after this group is created**.
- 3 Click **Apply**.

# Storing email address

## Searching for an email address

### Searching sequentially through memory

- 1 Select **Scan to** >  (**Address Book**) > **Search&Send** > Select an address group > **All** on the control panel.

OR

For the model with a touch screen, press  (**Setup**) > **Machine Setup** > **Next** > **Address Book** > **Email** > **View List** > **Individual** or **Group** on the touch screen.

- 2 Search through the entire memory in index (numerical) order, and select the name and address you want.

### Searching with a particular first letter

- 1 Select **Scan to** >  (**Address Book**) > **Search&Send** > Select an address group > **ID** on the control panel.

OR

For the model with a touch screen, press  (**Setup**) > **Machine Setup** > **Next** > **Address Book** > **Email** > **View Lists** > **Individual** or **Group** on the touch screen.

- 2 Enter the first few letters of the name you want.

For the model with a touch screen, press  (options) > **Search** > enter the first few letters of the name you want.

- 3 Press the arrows until the name and number you want appears.



# Entering various characters

As you perform various tasks, you may need to enter names and numbers. For example, when you set up your machine, you enter your name or your company's name, and the fax number. When you store fax numbers or email addresses in memory, you may also enter the corresponding names.

## Understanding keypad

Press the button until the correct letter appears on the display. For example, to enter the letter O, press 6, labeled with MNO. Each time you press 6, the display shows a different letter, M, N, O, m, n, o and finally 6.



- You can enter a space by pressing 1 twice.
- To delete the last digit or character, press the arrows button.
- Special character sets may differ from your machine depending on its options or the models.
- Some of the follow key values may not appear depending on the job you are doing.



Key	Assigned numbers, letters, or characters
1	@ / . ' 1
2	A B C a b c 2
3	D E F d e f 3
4	G H I g h i 4
5	J K L j k l 5
6	M N O m n o 6
7	P Q R S p q r s 7
8	T U V t u v 8
9	W X Y Z w x y z 9
0	& + - , 0
*	* % ^ _ ~ ! # \$ ( ) [ ] (These symbols are available when you type for network authentication.)
#	# =   ? " : { } < > ; (These symbols are available when you type for network authentication.)

# Entering various characters

## Understanding pop-up keyboard









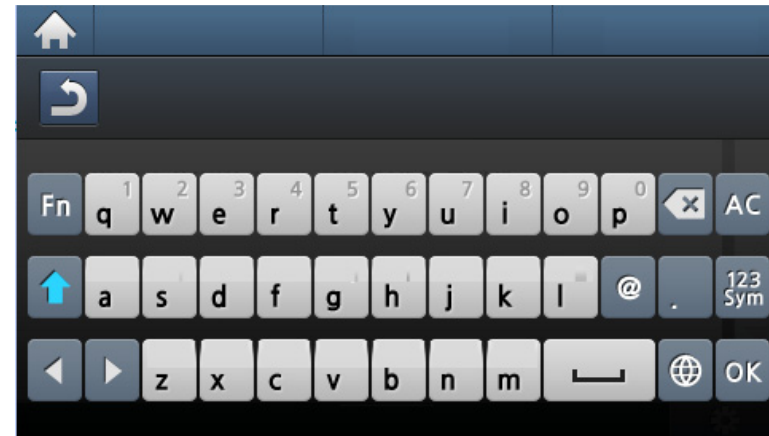

- This feature is only available for models with a touch screen. This feature is not supported for C306xND.
- Some of the follow key values may not appear depending on the job you are doing.

You can enter alphabet characters, numbers, diacritical marks, or special symbols using the keyboard on the home screen. This keyboard is specially arranged like a normal keyboard for better usability to the user.

Touch the input area where you need to enter alphabet characters, numbers, diacritical marks, or special symbols and the keyboard pops up on the screen.



- : Returns to the upper menu.
- : Deletes all characters in the input area.
- : Deletes character in the input area.
- : Moves the cursor between characters in the input area.
- : Saves and closes input result.
- : Enters a blank between characters. Also, you can insert a pause.
- : Toggles between lowercase keys and uppercase keys.
- : Switches from the alphanumeric keyboard to the numbers or special symbols keyboard.
- : Switches diacritical characters.

# Setting up the fax address book



This function is not supported for C306xND.

You can set up speed number with the fax numbers you use frequently via SyncThru™ Web Service and then easily and quickly enter fax numbers by entering the location numbers assigned to them in address book.

## Registering a speed dial number

- 1 Press (**Setup**) > **Machine Setup** > **Next** > **Address Book** > **Phone Book** > **View List** > **Individual** > (options) > **Add** on the touch screen.
- 2 Enter the name, fax number, email address, and speed dial number.
- 3 Press (Back).
- 4 Press the (Home) icon to return to ready mode.

## Using speed dial numbers

When you are prompted to enter a destination number while sending a fax, enter the speed dial number at which you stored the number you want.



- For a one-digit (0-9) speed dial number, press and hold the corresponding digit button on the number keypad for more than 2 seconds.
- For a two- or three-digit speed dial number, press the first digit button(s) and then hold down the last digit button for more than 2 seconds.





- 1 Press (**Fax**) > **Speed Dial Send** or **Group Dial Send** > **Next** on the touch screen.
- 2 Select the number you want.
- 3 Press **Send**.

## Editing speed dial numbers



- 1 Press (**Setup**) > **Machine Setup** > **Next** > **Address Book** > **Phone Book** > **View List** > **Individual** on the touch screen.
- 2 Select the speed dial number you want to edit.
- 3 Press (Back).
- 4 Press the (Home) icon to return to ready mode.

# Setting up the fax address book

## Registering a group dial number



- 1 Press  (**Setup**) > **Machine Setup** > **Next** > **Address Book** > **Phone Book** > **View List** > **Group** >  (options) > **Add** on the touch screen.
- 2 Press the **Group Members** > **Phone Book**.
- 3 Select an individual address and press  (Back).
- 4 Select the name and number you want and press **OK**.
- 5 Select **Yes** when **Add?** appears.
- 6 Repeat step 3 to include other speed dial numbers into the group.
- 7 When you have finished, select **No** when **Another No.?** appears and press **OK**.
- 8 Press the  (Home) icon to return to ready mode.

## Editing group dial numbers

- 1 Press  (**Setup**) > **Machine Setup** > **Next** > **Address Book** > **Phone Book** > **View List** > **Group** on the touch screen.
- 2 Press **Name** > edit the group name using the keyboard.
- 3 Press **Group Members** > add or delete the group number using the **Phone Book**.
- 4 Press the  (Home) icon to return to ready mode.

## Searching address book for an entry

There are two ways to search for a number in memory. You can either scan from A to Z sequentially, or you can search by entering the first letters of the name associated with the number.

- 1 Press  (**Setup**) > **Machine Setup** > **Next** > **Address Book** > **Phone Book** > **View Lists** > **Group** >  (options) > **Search** on the touch screen.
- 2 Enter the name, number, or letter you want to search and press **OK** from the keyboard.
- 3 Press the  (Home) icon to return to ready mode.

## Exporting Address Book

You can import the address book saved in the machine to the computer in CSV file format using SyncThru™ Web Service.

- 1 Access the SyncThru™ Web Service (see "SyncThru™ Web Service" on page 296).
- 2 Click **Login** on the upper right of the SyncThru™ Web Service website.

# Setting up the fax address book

- 3 Type in the **ID** and **Password** then click **Login**. We recommend you to change the default password for security reasons.
  - **ID: admin**
  - **Password: sec00000**
- 4 Click **Address Book** tab > **Individual**.
- 5 Select **Export** form the **Task** drop down list.
- 6 Select the option you want and click the **Export** button.  
Then the address book file stored in your computer.

## Importing Address Book

You can edit the exported address book in CSV file format and send it back to the machine by exporting to the machine from your computer.



Followings are the conditions for editing the imported CSV file.

- Password-protected or security enhanced CSV file cannot be edited.
- The CSV file needs to be saved in Notepad program in UTF-8.
- Do not change the first row (model name, version, title field).
- Use comma(,) as a separator.

- When importing the address book data from a computer to the machine, the existing address book data is deleted.
- Make sure to enter valid data. If you enter invalid data, unexpected errors can occur. Refer to the below rules for entering valid data.
  - **Speed dial:** A number is required for each address. You cannot use duplicate numbers. Only numbers are allowed.
  - **User Name:** This field is not mandatory. You can enter up to 64 byte in UTF-8. <, ", >, \, / in not allowed.
  - **Fax:** This field is not mandatory. You can enter up to 40 byte using numbers (0-9) and special characters (#, \*, -).
  - **E-mail:** This field is not mandatory. You can enter up to 128 byte in email address format (ex: printer@domain.com)

- 1 Access the SyncThru™ Web Service (see "SyncThru™ Web Service" on page 296).
- 2 Click **Login** on the upper right of the SyncThru™ Web Service website.
- 3 Type in the **ID** and **Password** then click **Login**. We recommend you to change the default password for security reasons.
  - **ID: admin**
  - **Password: sec00000**
- 4 Click **Address Book** tab > **Individual**.
- 5 Select **Import** form the **Task** drop down list.
- 6 Select **Browse**, and select the stored file.
- 7 Click **Import** > **OK**.

# Setting up the fax address book

## Printing address book

You can check your **Address Book** settings by printing a list.

- 1 Press  (**Setup**) > **Machine Setup** > **Next** > **Report** > **Address Book** on the touch screen.
- 2 Press **Yes** when the confirmation windows appears.  
The machine begins printing.

# Registering authorized users



This feature may not be available depending on model or optional goods (see "Features by model" on page 7).

To send a scanned image, copy image, or fax data through email or via network server safely, you must register account information of authorized users to your local machine using SyncThru™ Web Service.

- 1 Access the SyncThru™ Web Service (see "SyncThru™ Web Service" on page 296).
- 2 Click **Login** on the upper right of the SyncThru™ Web Service website.
- 3 Type in the **ID** and **Password** then click **Login**. We recommend you to change the default password for security reasons.
  - **ID: admin**
  - **Password: sec00000**
- 4 Click **Security > User Access Control > Authentication**.
- 5 Select **Basic Authentication** in the **Authentication Mode**, and select **Local Authentication** in the **Authentication Method**, and click.
- 6 Click **Apply**.
- 7 Click **OK** in the confirmation pop-up window.
- 8 Click **User Profile > Add**.

- 9 Enter **User Name, Login ID, Password, Confirm Password, E-mail Address, and Fax Number**.



You can easily add individual address if you check **Yes** for **Add individual(s) after this group is created**.

- 10 Click **Apply**.

# Printing features



- For basic printing features, refer to the Basic Guide (see "Basic printing" on page 57).
- This feature may not be available depending on model or optional goods (see "Features by model" on page 7).

## Changing the default print settings



Most Windows applications will override settings you specify in the printer driver. Change all print settings available in the software application first, and change any remaining settings using the printer driver.

- 1 For Windows XP Service Pack 3/Server 2003, from the **Start** menu, select **Printer and Faxes**.
  - For Windows Server 2008/Vista, from the **Start** menu, select Control Panel > **Hardware and Sound** > **Printers**.
  - For Windows 7, from the **Start** menu, select Control Panel > **Devices and Printers**.  
For Windows 8, from the **Charms**, select **Search** > **Settings** > **Control Panel** > **Devices and Printers**.
  - For Windows Server 2008 R2, select **Control Panel** > **Hardware** > **Devices and Printers**.

- For Windows 10 / Windows Server 2016  
From task bar, type in **Devices and Printers** in **Search** input area. Press the Enter key.  
OR  
From the **Start** () icon, select **Settings** > **Devices** > **Printers & scanners** > **Devices and Printers**.



Right-click the **Start** () icon, you can select **Control Panel** > **Devices and Printers**.

- 2 Right-click on your machine.
- 3 For Windows XP Service Pack 3/Server 2003/Server 2008/Vista, select **Printing Preferences**.  
For Windows 7/8, Windows Server 2008 R2, Windows 10, or Windows Server 2016 from context menus, select **Printing preferences**.



If **Printing preferences** has a ►, you can select other printer drivers connected to the selected printer.

- 4 Change the settings on each tab.
- 5 Click **OK**.



# Printing features



If you want to change the settings for each print job, change it in **Printing Preferences**.

## Setting your machine as a default machine

**1** For Windows XP Service Pack 3/Server 2003, from the **Start** menu, select **Printer and Faxes**.

- For Windows Server 2008/Vista, from the **Start** menu, select Control Panel > **Hardware and Sound** > **Printers**.
- For Windows 7, from the **Start** menu, select Control Panel > **Devices and Printers**.

For Windows 8, from the **Charms**, select **Search** > **Settings** > **Control Panel** > **Devices and Printers**.

- For Windows Server 2008 R2, select **Control Panel** > **Hardware** > **Devices and Printers**.
- For Windows 10 / Windows Server 2016

From task bar, type in **Devices and Printers** in **Search** input area. Press the Enter key.

OR

From the **Start** (  ) icon, select **Settings** > **Devices** > **Printers & scanners** > **Devices and Printers**.



Right-click the **Start** (  ) icon, you can select **Control Panel** > **Devices and Printers**.

**2**

Select your machine.

**3**

Right-click your machine and select **Set as Default Printer**.



For Windows 7 or Windows Server 2008 R2, if **Set as default printer** has a ►, you can select other printer drivers connected to the selected printer.

## Using advanced print features



**XPS printer driver:** used to print XPS file format.

- See "Features by model" on page 7.
- The XPS printer driver can be installed only on Windows Vista OS or higher.
- Install optional memory when an XPS job does not print because the printer is out of memory.
- For models that provide XPS driver from the Samsung website, <http://www.samsung.com> > find your product > Support or downloads.

# Printing features

## Printing to a file (PRN)

You will sometimes need to save the print data as a file.

- 1 Check the **Print to file** box in the **Print** window.

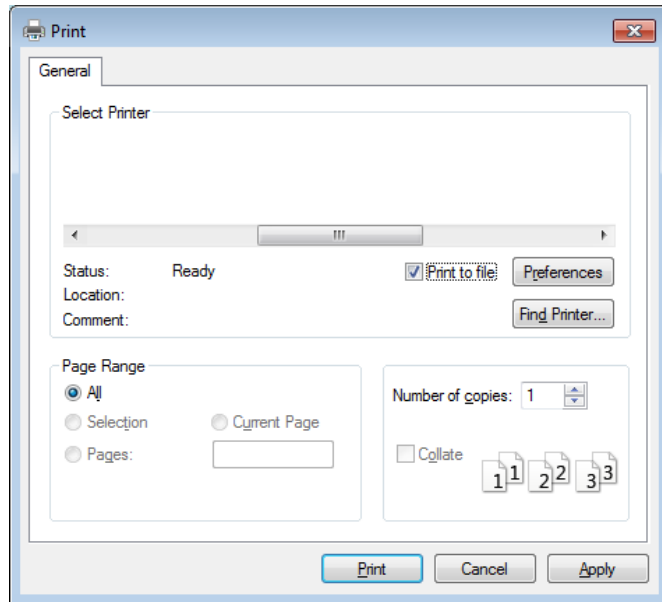

- 2 Click **Print**.
- 3 Type in the destination path and the file name, and then click **OK**.  
For example, **c:\Temp\file name**.



If you type in only the file name, the file is automatically saved in **My Documents**, **Documents and Settings**, or **Users**. The saved folder may differ, depending on your operating system or the application you are using.

# Printing features

## Understanding special printer features

You can use advanced printing features when using your machine.



To take advantage of the printer features provided by your printer driver, click **Properties** or **Preferences** in the application's **Print** window to change the print settings. The machine name that appears in the printer properties window may differ depending on the machine in use.





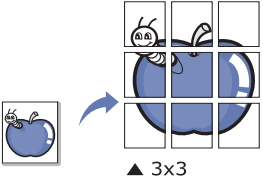
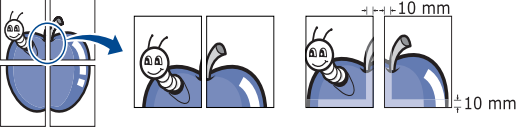
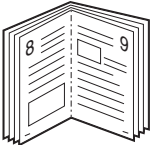

- Some menus may not appear on the display depending on options or models. If so, it is not applicable to your machine.
- Select the **Help** menu or click the  button from the window or press **F1** on your keyboard and click on any option you want to know about (see "Using help" on page 60).

Item	Description
<p data-bbox="51 815 315 887"><b>Multiple Pages per Side</b></p>  An icon showing two pages of a document, labeled '1' and '2', representing multiple pages per side.	<p data-bbox="383 815 2175 887">Selects the number of pages to print on a single sheet of paper. To print more than one page per sheet, the pages will be reduced in size and arranged in the order you specify. You can print up to 16 pages on one sheet.</p>

# Printing features

Item	Description
<p><b>Poster Printing</b></p> 	<p>Prints a single-page document onto 4 (Poster 2x2), 9 (Poster 3x3), or 16 (Poster 4x4) sheets of paper, for the purpose of pasting the sheets together to form one poster-size document.</p> <p>Select the <b>Poster Overlap</b> value. Specify <b>Poster Overlap</b> in millimeters or inches by selecting the radio button on the upper right of <b>Basic</b> tab to make it easier to paste the sheets together.</p> 
<p><b>Booklet Printing<sup>a</sup></b></p> 	<p>Prints your document on both sides of a sheet of paper and arranges the pages so that the paper can be folded in half after printing to produce a booklet.</p> <ul style="list-style-type: none"><li>• If you want to make a booklet, you need to print on Letter, Legal, A4, US Folio, or Oficio sized print media.</li><li>• The <b>Booklet Printing</b> option is not available for all paper sizes. Select the available paper <b>Size</b> option under the <b>Paper</b> tab to see what paper sizes are available.</li><li>• If you select an unavailable paper size, this option can be automatically canceled. Select only available paper (paper without  or  mark).</li></ul>
<p><b>Double-sided Printing<sup>a</sup></b></p>	<p>Print on both sides of a sheet of paper (duplex). Before printing, decide how you want your document oriented.</p> <ul style="list-style-type: none"><li>• You can use this feature with Letter, Legal, A4, US Folio or Oficio sized paper</li><li>• If your machine does not have a duplex unit, you should complete the printing job manually. The machine prints every other page of the document first. After that, a message appears on your computer.</li></ul>

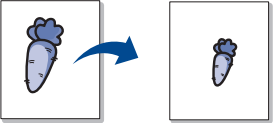
# Printing features

Item	Description
<b>Double-sided Printing<sup>a</sup></b>	<ul style="list-style-type: none"><li>• <b>Printer Default:</b> If you select this option, this feature is determined by the settings you have selected on the control panel of the machine.</li><li>• <b>None:</b> Disables this feature.</li><li>• <b>Long Edge:</b> This option is the conventional layout used in bookbinding. </li><li>• <b>Short Edge:</b> This option is the conventional layout used in calendars. </li><li>• <b>Reverse Double-Sided Printing:</b> Check this option to reverse the print order when duplex printing.</li></ul>
<b>Paper Options</b> 	Changes the size of a document to appear larger or smaller on the printed page by entering in a percentage by which to enlarge or decrease the document.
<b>Watermark</b> 	The watermark option allows you to print text over an existing document. For example, you use it when you want to have large gray letters reading <b>"DRAFT"</b> or <b>"CONFIDENTIAL"</b> printed diagonally across the first page or all pages of a document.

# Printing features

Item	Description
<b>Watermark</b> <b>(Creating a watermark)</b>	<p><b>a</b> To change the print settings from your software application, access <b>Printing Preferences</b>.</p> <p><b>b</b> Click the <b>Advanced</b> tab, select <b>Edit</b> from the <b>Watermark</b> drop-down list. The <b>Edit Watermarks</b> window appears.</p> <p><b>c</b> Enter a text message in the <b>Watermark Message</b> box. You can enter up to 256 characters. The message displays in the preview window.</p>
<b>Watermark</b> <b>(Editing a watermark)</b>	<p><b>a</b> To change the print settings from your software application, access <b>Printing Preferences</b>.</p> <p><b>b</b> Click the <b>Advanced</b> tab, select <b>Edit</b> from the <b>Watermark</b> drop-down list. The <b>Edit Watermarks</b> window appears.</p> <p><b>c</b> Select the watermark you want to edit from the <b>Current Watermarks</b> list and change the watermark message and options.</p> <p><b>d</b> Click <b>Update</b> to save the changes.</p> <p><b>e</b> Click <b>OK</b> or <b>Print</b> until you exit the <b>Print</b> window.</p>
<b>Watermark</b> <b>(Deleting a watermark)</b>	<p><b>a</b> To change the print settings from your software application, access <b>Printing Preferences</b>.</p> <p><b>b</b> Click the <b>Advanced</b> tab, select <b>Edit</b> from the <b>Watermark</b> drop-down list. The <b>Edit Watermarks</b> window appears.</p> <p><b>c</b> Select the watermark you want to delete from the <b>Current Watermarks</b> list and click <b>Delete</b>.</p> <p><b>d</b> Click <b>OK</b> or <b>Print</b> until you exit the <b>Print</b> window.</p>
<b>Overlay<sup>a</sup></b>	<p>This option is available only when you use the PCL/SPL printer driver (see "Software" on page 7).</p> <p>An overlay is text and/or images stored in the computer hard disk drive (HDD) as a special file format that can be printed on any document. Overlays are often used to take the place of letterhead paper. Rather than using preprinted letterhead, you can create an overlay containing exactly the same information that is currently on your letterhead. To print a letter with your company's letterhead, you do not need to load preprinted letterhead paper in the machine: just print the letterhead overlay on your document.</p> <p>To use a page overlay, you must create a new page overlay containing your logo or image.</p> <div data-bbox="383 1230 2197 1390"><ul style="list-style-type: none"><li>• The overlay document size must be the same as the document you print with the overlay. Do not create an overlay with a watermark.</li><li>• The resolution of the overlay document must be the same as that of the document you will print with the overlay.</li></ul></div>



# Printing features



Item	Description
<b>Overlay<sup>a</sup></b> <b>(Creating a new page overlay)</b>	<p>To use a page overlay, you must create a new page overlay containing your logo or image.</p> <ol style="list-style-type: none"><li><b>a</b> Create or open a document containing text or an image for use in a new page overlay. Position the exactly as you wish them to appear when printed as an overlay.</li><li><b>b</b> To save the document as an overlay, access <b>Printing Preferences</b>.</li><li><b>c</b> Click the <b>Advanced</b> tab, and select <b>Create</b> from the <b>Overlay</b> drop-down list.</li><li><b>d</b> In the <b>Save As</b> window, type a name up to eight characters in the <b>File name</b> box. Select the destination path, if necessary (The default is C:\Formover).</li><li><b>e</b> Click <b>Save</b>.</li><li><b>f</b> Click <b>OK</b> or <b>Print</b> until you exit the <b>Print</b> window. When a confirming message window appears, click <b>Yes</b>.</li><li><b>g</b> The file is not printed. Instead, it is stored on your computer hard disk drive.</li></ol>
<b>Overlay<sup>a</sup></b> <b>(Using a page overlay)</b>	<p>After an overlay has been created, it is ready to be printed with your document. To print an overlay with a document:</p> <ol style="list-style-type: none"><li><b>a</b> Create or open the document you want to print.</li><li><b>b</b> To change the print settings from your software application, access <b>Printing Preferences</b>.</li><li><b>c</b> Click <b>Advanced</b> tab.</li><li><b>d</b> Select the <b>Print Overlay</b> from the <b>Overlay</b> drop-down list.</li><li><b>e</b> If the overlay file you want does not appear in the <b>Overlay File 1</b> or <b>Overlay File 2</b> drop-down list, select <b>Load</b> from the <b>Overlay List</b>. Select the overlay file you want to use. If you have stored the overlay file you want to use in an external source, you can also load the file when you access the <b>Open</b> window. After you select the file, click <b>Open</b>. The file appears in the <b>Overlay List</b> box and is available for printing. Select the overlay from the <b>Overlay List</b> box.</li><li><b>f</b> If necessary, check <b>Confirm Page Overlay When Printing</b> box. If this box is checked, a message window appears each time you submit a document for printing, asking you to confirm your wish to print an overlay on your document. If this box is not checked and an overlay has been selected, the overlay automatically prints with your document.</li><li><b>g</b> Click <b>OK</b> or <b>Print</b> until you exit the <b>Print</b> window. The selected overlay prints on your document.</li></ol>

# Printing features



Item	Description
<b>Overlay<sup>a</sup></b> <b>(Deleting a page overlay)</b>	<p>You can delete page overlays that you no longer use.</p> <ul style="list-style-type: none"><li><b>a</b> In the <b>Printing Preferences</b> window, click the <b>Advanced</b> tab.</li><li><b>b</b> Select <b>Print Overlay</b> from the <b>Overlay</b> drop-down list.</li><li><b>c</b> Select the overlay you want to delete from the <b>Overlay List</b> box. If the overlay file you want does not appear in the <b>Overlay List</b>, select <b>Load</b> from the Overlay List. Select the overlay file you want to delete.</li><li><b>d</b> Click <b>Delete</b>.</li><li><b>e</b> When a confirming message window appears, click <b>Yes</b>.</li><li><b>f</b> Click <b>OK</b> or <b>Print</b> until you exit the <b>Print</b> window.</li></ul>



# Printing features

Item	Description
<b>Print Mode</b>	<div data-bbox="383 284 2197 584"><ul style="list-style-type: none"><li>• This feature is available only if you have installed the mass device or optional memory (see "Variety feature" on page 8).</li><li>• Some menus may not appear on the display depending on options or models. If so, it is not applicable to your machine.</li><li>• You need to check <b>Storage Options</b> to use this feature (see "Setting Device Options" on page 94).</li><li>• Without installing the mass storage device in the machine, the Ram Disk feature provides only 3 options: <b>Normal, Proof, and Confidential</b>.</li></ul></div> <div data-bbox="383 603 2197 783"><ul style="list-style-type: none"><li>• <b>Print Mode:</b> The default <b>Print Mode</b> is <b>Normal</b>, which is for printing without saving the printing file in the memory.<ul style="list-style-type: none"><li>- <b>Normal:</b> This mode prints without storing your document in the optional memory.</li><li>- <b>Proof:</b> This mode is useful when you print more than one copy. You can print one copy first to check, then print the rest of the copies later.</li><li>- <b>Confidential:</b> This mode is used for printing confidential documents. You need to enter a password to print.</li></ul></li></ul></div> <div data-bbox="383 831 2197 1174"><ul style="list-style-type: none"><li>• <b>Job Name:</b> This option is used when you need to find a stored file using the control panel.</li><li>• <b>User ID:</b> This option is used when you need to find a stored file using the control panel. The user name automatically appears as the user name that you use to log on Windows.</li><li>• <b>Enter Password:</b> If the <b>Property</b> of the document box you selected is <b>Secured</b>, you have to enter the password for the document box. This option is used for loading a stored file using the control panel.</li><li>• <b>Confirm Password:</b> Re-enter the password to confirm it.</li></ul></div>

# Printing features

Item	Description
<b>Job Accounting</b>	<p>This option allows you to print with the given permission.</p> <ul style="list-style-type: none"><li>• <b>User permission:</b> If you check this option, only users with user permission can start a print job.</li><li>• <b>Group permission:</b> If you check this option, only groups with group permission can start a print job.</li></ul> <div data-bbox="383 459 2197 635"><ul style="list-style-type: none"><li>• Click the question mark (  ) from the upper-right corner of the window and click on any option you want to know about.</li><li>• Administrators can enable job accounting and configure permissions in the control panel or SyncThru™ Web Service.</li></ul></div>
<b>Job Encryption</b>	<p>Encrypts printing data first, and transmits it to the machine. This feature protects the printing information even though the data is snatched on a network.</p> <div data-bbox="383 794 2197 954"><p><b>Job Encryption</b> feature is enabled only when the mass storage device is installed. The mass storage device is used to decrypt the printing data (see "Variety feature" on page 8).</p></div>

a. This option is not available when you use XPS driver.

# Printing features

## Using Direct Printing Utility



- Direct Printing Utility may not be available depending on model or optional goods (see "Software" on page 7).
- Available for Windows OS users only.

## What is Direct Printing Utility?

Direct Printing Utility is a program that sends the PDF files directly to your machine to print without having to open the file.

To install this program:

Download the software from the Samsung website then unpack and install it: (<http://www.samsung.com> > find your product > Support or Downloads).



- You cannot print PDF files that are restricted. Deactivate the printing restriction feature and retry printing.
- You cannot print PDF files that are restricted by a password. Deactivate the password feature, and retry printing.
- Whether or not a PDF file can be printed using the Direct Printing Utility program depends on how the PDF file was created.
- The Direct Printing Utility program supports PDF version 1.7 and below. For higher versions, you must open the file to print it.

## Printing

There are several ways you can print using the Direct Printing Utility.

- 1 From the **Start** menu select **Programs** or **All Programs > Samsung Printers**.
  - For Windows 8, from **Charms**, select **Search > Apps**.
  - For Windows 10 / Windows Server 2016  
From task bar, type in **Samsung Printers** in **Search** input area. Press the Enter key.OR  
From the **Start** () icon, select **All apps > Samsung Printers**.
- 2 Press **Direct Printing Utility**.
- 3 Select your machine from the **Select Printer** drop-down list and click **Browse**.
- 4 Select the file you wish to print and click **Open**.  
The file is added in the **Select Files** section.
- 5 Customize the machine settings for your needs.
- 6 Click **Print**. The selected PDF file is sent to the machine.

# Printing features

## Using the right-click menu

---

- 1 Right-click on the PDF file to print and select **Direct Printing**.  
The Direct Printing Utility window appears with the PDF file is added.
- 2 Select the machine to use.
- 3 Customize the machine settings.
- 4 Click **Print**. The selected PDF file is sent to the machine.

## Mac printing



Some features may not be available depending on models or options. It means that the features are not supported.

## Printing a document

---

When you print with a Mac, you need to check the printer driver settings in each application you use. Follow the steps below to print from a Mac:

- 1 Open the document to print.
- 2 Open the **File** menu and click **Page Setup (Document Setup** in some applications).
- 3 Choose your paper size, orientation, scaling, other options, and make sure that your machine is selected. Click **OK**.
- 4 Open the **File** menu and click **Print**.
- 5 Choose the number of copies and indicate which pages to print.
- 6 Click **Print**.

## Changing printer settings

---

You can use advanced printing features when using your machine.

Open an application and select **Print** from the **File** menu. The machine name, which appears in the printer properties window, may differ depending on the machine in use. Except for the name, the composition of the printer properties window is similar to the following.

## Printing multiple pages on one sheet

---

You can print more than one page on a single sheet of paper. This feature provides a cost-effective way to print draft copies.

# Printing features

- 1 Open an application, and select **Print** from the **File** menu.
- 2 Select **Layout** from the drop-down list under **Orientation**. In the **Pages per Sheet** drop-down list, select the number of pages you want to print on one sheet of paper.
- 3 Select the other options to use.
- 4 Click **Print**.  
The machine prints the selected number of pages to print on one sheet of paper.

## Printing on both sides of the paper



Some features may not be available depending on models or options. It means that the features are not supported.

Before printing in the duplex mode, decide on which edge you will be binding your finished document. The binding options are, as follows:

- **Long-Edge Binding:** This option is the conventional layout used in book binding.
- **Short-Edge Binding:** This option is the type often used with calendars.

- 1 From your Mac application, select **Print** from the **File** menu.
- 2 Select **Layout** from the drop-down list under **Orientation**.

- 3 Select a binding orientation from the **Two-Sided** option.
- 4 Select the other options to use.
- 5 Click **Print** and the machine prints on both sides of the paper.



If you print more than 2 copies, the first copy and the second copy might print on the same sheet of paper. Avoid printing on both sides of paper when you are printing more than 1 copy.

## Using help

Click the question mark on the bottom-left corner of the window and click on the topic you want to know about. A pop-up window appears with information about that option's feature, which is provided from the driver.

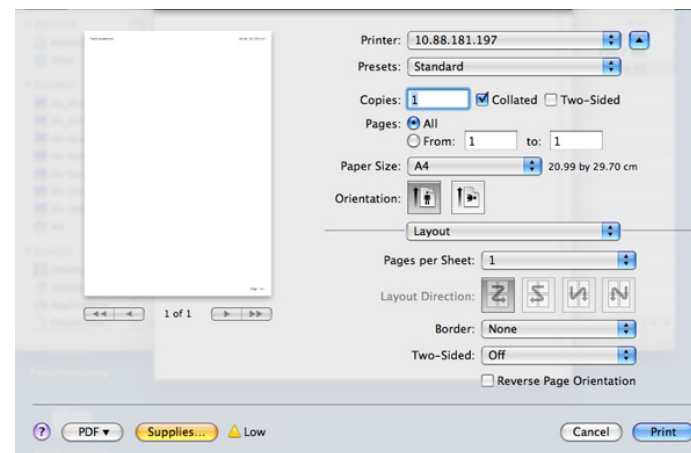

# Printing features

## Linux printing



Some features may not be available depending on models or options. It means that the features are not supported.

## Printing from applications

There are a lot of Linux applications that allow you to print using Common UNIX Printing System (CUPS). You can print on your machine from any such application.

- 1 Open the document to print.
- 2 Open the **File** menu and click **Page Setup (Print Setup** for some applications).
- 3 Choose your paper size, orientation, and make sure that your machine is selected. Click **Apply**.
- 4 Open the **File** menu and click **Print**.
- 5 Select your machine to print.
- 6 Choose the number of copies and indicate which pages to print.

7 Change other printing options in each tab, if necessary.

8 Click **Print**.



Automatic/manual duplex printing may not be available depending on models. You can alternatively use the lpr printing system or other applications for odd-even printing.

## Printing files

You can print text, image, pdf files on your machine using the standard CUPS directly from the command line interface. The CUPS lp or lpr utility allows you to do that. You can print these files by using below command format.

```
"lp -d <printer name> -o <option> <file name>"
```

Please refer to lp or lpr man page on your system for more details.

## Configuring Printer Properties

You can change the default printing options or connection type with Printing utility supplied by o/s.

# Printing features

- 1 Launch Printing utility(Go to **System > Administration > Printing** menu or execute "**system-config-printer**" command in Terminal program).
- 2 Select your printer and double-click it.
- 3 Change default printing options or connection type.
- 4 Click **Apply** button.

## Unix printing



Some features may not be available depending on models or options. It means that the features are not supported.

## Proceeding the print job

After installing the printer, choose any of the image, text, or PS files to print.

- 1 Execute "**printui <file\_name\_to\_print>**" command.  
For example, if you are printing "**document1**"  
**printui document1**  
This will open the UNIX Printer Driver **Print Job Manager** in which the user can select various print options.
- 2 Select a printer that has been already added.

- 3 Select the printing options from the window such as **Page Selection**.
- 4 Select how many copies are needed in **Number of Copies**.



To take advantage of the printer features provided by your printer driver, press **Properties**.

- 5 Press **OK** to start the print job.

## Changing the machine settings

The UNIX printer driver **Print Job Manager** in which the user can select various print options in printer **Properties**.

The following hot keys may also be used: "H" for **Help**, "O" for **OK**, "A" for **Apply**, and "C" for **Cancel**.

## General tab

- **Paper Size:** Set the paper size as A4, Letter, or other paper sizes, according to your requirements.
- **Paper Type:** Choose the type of the paper. Options available in the list box are **Printer Default**, **Plain**, and **Thick**.
- **Paper Source:** Select from which tray the paper is used. By default, it is **Auto Selection**.
- **Orientation:** Select the direction in which information is printed on a page.
- **Duplex:** Print on both sides of paper to save paper.

# Printing features



Automatic/manual duplex printing may not be available depending on models. You can alternatively use the lpr printing system or other applications for odd-even printing.

- **Multiple pages:** Print several pages on one side of the paper.
- **Page Border:** Choose any of the border styles (e.g., **Single-line hairline**, **Double-line hairline**)

## Image tab

In this tab, you can change the brightness, resolution, or image position of your document.

## Text tab

Set the character margin, line space, or the columns of the actual print output.

## Margins tab

- **Use Margins:** Set the margins for the document. By default, margins are not enabled. The user can change the margin settings by changing the values in the respective fields. Set by default, these values depend on the page size selected.
- **Unit:** Change the units to points, inches, or centimeters.

## Printer-Specific Settings tab

Select various options in the **JCL** and **General** frames to customize various settings. These options are specific to the printer and depend on the PPD file.



# Scan features



- For basic scanning features, refer to the Basic Guide (see "Basic scanning" on page 69).
- This feature may not be available depending on model or optional goods (see "Features by model" on page 7).
- The maximum resolution that can be achieved depends upon various factors, including computer speed, available disk space, memory, the size of the image being scanned, and bit depth settings. Thus, depending on your system and what you are scanning, you may not be able to scan at certain resolutions, especially using enhanced dpi.

## Basic scanning method



This feature may not be available depending on model or optional goods (see "Variety feature" on page 8).

You can scan the originals with your machine via an USB cable or the network. The following methodologies can be used for scanning your documents:

- **Scan to PC:** Scan the originals from the control panel. The scanned data will be stored in the connected computers **My Documents** folder (see "Basic Scanning" on page 69).
- **Email:** You can send the scanned image as an email attachment (See "Scanning to email" on page 279).

- **FTP/SMB:** You can scan an image and upload it to an FTP/SMB server (see "Scanning to FTP/SMB server" on page 280).
- **Scan to WSD:** Scans the originals and saves the scanned data on a connected computer if the computer supports the WSD (Web Service for Device) feature (see "Scanning to WSD" on page 281).
- **Scan to Samsung Cloud:** You can scan an image and the scanned data will be stored in the cloud service (see "Scanning and sending to Samsung Cloud Print" on page 205).
- **Samsung Easy Document Creator:** You can use this program to scan images or documents (see "Scanning with Samsung Easy Document Creator" on page 283).
- **TWAIN:** TWAIN is one of the a preset imaging applications. Scanning an image launches the selected application, enabling you to control the scanning process. This feature can be used via the local connection or the network connection (see "Scanning from image editing program" on page 282).
- **WIA:** WIA stands for Windows Images Acquisition. To use this feature, your computer must be connected directly with the machine via an USB cable (see "Scanning using the WIA driver" on page 283).
- **USB Memory:** You can scan a document and save the scanned image onto an USB memory device (see "Scanning" on page 76).

# Scan features

## Setting the scan settings in the computer



This feature may not be available depending on model or optional goods (see "Features by model" on page 7).

- 1 Open **Samsung Easy Printer Manager** (see "Using Samsung Easy Printer Manager" on page 309).
- 2 Select the appropriate machine from the **Printer List**.
- 3 Select **Advanced Setting** > **Scan to PC Settings** menu.
- 4 Select the option you want.
  - **Scan Activation:** Determines whether or not scanning is enabled on the device.
  - **Basic** tab: Contains settings related to general scan and device settings.
  - **Image** tab: Contains settings related to image altering.
- 5 Press **Save** > **OK**.

## Scanning from network connected machine



This feature is not available for the machine that does not support the network interface (see "Features by model" on page 7).

Make sure the printer driver is installed on your computer using the software CD, since the printer driver includes the scan program (see "Installing the driver locally" on page 24).

- 1 Place a single document face down on the document glass, or load the documents face up into the document feeder (see "Loading originals" on page 54).
- 2 Select **Scan to** > **Scan to PC** > **Network PC** on the control panel.  
OR  
For the model with a touch screen, press  (**Scan**) > **Network PC** > **Next** select the scan destination you want on the touch screen.



If you see **Not Available** message, check the port connection.

- 3 Select your registered computer **ID**, and enter the **Password** if necessary.
- 4 Select the option you want and press **OK**.  
For the model with a touch screen, press  (Option settings) > select the option you want using arrows > **Start** button on the touch screen.
- 5 Scanning begins.



Scanned image is saved in computer's **Documents\Scan** folder. The saved folder may differ, depending on your operating system or the application you are using.

# Scan features

## Scanning to email



This feature may not be available depending on model or optional goods (see "Features by model" on page 7).

## Setting up an email account

- 1 Access the SyncThru™ Web Service (see "SyncThru™ Web Service" on page 296).
- 2 Select **Settings > Network Settings** and **Outgoing Mail Server(SMTP)**.
- 3 Enter the IP address in dotted decimal notation or as a host name.
- 4 Enter the server port number, from 1 to 65535.
- 5 Check the box next to **SMTP Requires Authentication** to require authentication.
- 6 Enter the SMTP server login name and password.
- 7 Press **Apply**.



- If the authentication method of SMTP server is POP3 before SMTP, put a check mark of **SMTP Requires POP Before SMTP Authentication**.
- Enter the IP address and port number.

## Scanning and sending an email

- 1 Place a single document face down on the document glass, or load the documents face up into the document feeder (see "Loading originals" on page 54).
- 2 Select **Scan to > Scan to Email** on the control panel.  
OR

For the model with a touch screen, press  (**Scan**) > **Email** > **Next** on the touch screen.

- 3 Enter the sender's and recipient's email address and press **OK**.

For the model with a touch screen, press **Direct Input** or **Address Book** > enter the sender's and recipient's email address using number keypad on the touch screen.



- You can send an email to yourself by activating the **Auto Send To Self** option in the **Settings > Scan > Scan to E-mail** on SyncThru™ Web Service.
- Enter the login name and password if you configured on SyncThru™ Web Service (see "SyncThru™ Web Service" on page 296).

- 4 Select the file format to scan, and press **OK**.

For the model with a touch screen, press  (Option settings) > select the option you want using arrows > **Start** button on the touch screen.

- 5 The machine begins scanning and then sends the email.

# Scan features

## Scanning to FTP/SMB server



This feature may not be available depending on model or optional goods (see "Features by model" on page 7).

## Setting up an FTP/SMB server



- 1 Access the SyncThru™ Web Service (see "SyncThru™ Web Service" on page 296).
- 2 Select **Address Book > Individual > Add**.
- 3 Check the box next to **Add FTP or Add SMB**.
- 4 Enter the IP address in dotted decimal notation or as a host name.
- 5 Enter the server port number, from 1 to 65535.
- 6 Check the box next to **Anonymous**, then the server permits the access of unauthorized people.
- 7 Enter the login name and password.
- 8 Enter the domain name if your server is joined to the certain domain, otherwise just enter your computer name which is registered to the SMB server.
- 9 Enter the path for saving the scanned image.



- The folder to save the scanned image must be on the root.
- The folder properties need to be setup as a share.
- Your user name should have the rights to read and write the folder.

- 10 Press **Apply**.

## Scanning and sending to FTP/SMB server

- 1 Make sure that your machine is connected to a network.
- 2 Place a single document face down on the document glass, or load the documents face up into the document feeder (see "Loading originals" on page 54).
- 3 Select **Scan to > Scan to SMB or Scan to FTP** on the control panel.  
OR  
For the model with a touch screen, press  (**Scan**) > **SMB or FTP > Next** on the touch screen.
- 4 Select a server and scan format you want.  
For the model with a touch screen, press  (Option settings) > select the option you want using arrows > **Start** button on the touch screen.
- 5 The machine begins scanning and then sends the scanned image to the specified server.

# Scan features

## Scanning to WSD

Scans the originals and saves the scanned data on a connected computer if the computer supports the WSD (Web Service for Device) feature. To use the WSD feature, you need to install the WSD printer driver on your computer. For Windows 7, you can install the WSD driver by **Control Panel > Devices and Printers > Add a printer**. Click **Add a network, wireless or Bluetooth printer** from the wizard.



- The machine that does not support the network interface, it will not be able to use this feature.
- The WSD feature works only with Windows Vista® or later version that are the WSD-compliant computer.
- The following installation steps are based on Windows 7 computer.

## Installing a WSD Printer Driver

- 1 Select **Start > Control Panel > Devices and Printers > Add a printer**.
- 2 Click **Add a network, wireless or Bluetooth printer** from the wizard.
- 3 In the printers list, select the one you want to use, and then click **Next**.



- The IP address for WSD printer is `http://IP address/ws/` (example: `http://111.111.111.111/ws/`).
- If no WSD printer is displayed in the list, click **The printer that I want isn't listed > Add a printer using a TCP/IP address or hostname** and select **Web Services Device** from **Device type**. Then enter the printer's IP address.

- 4 Follow the instructions in the installation window.

## Scanning using the WSD feature



This feature is only available for models with a touch screen. This feature is not supported for C306xND.

- 1 Make sure that the machine is connected to your computer and powered on.
- 1 Place a single document face down on the document glass, or load the documents face up into the document feeder (see "Loading originals" on page 54).
- 2 Select (Scan) > **WSD > Next** on the control panel.

# Scan features



If you see **Not Available** message, check the port connection. Or check the printer driver for WSD is correctly installed.

- 3 Select your computer name from **Destination** list.
- 4 Select the option you want and press **Start**.
- 5 Scanning begins.

## Scanning from image editing program

You can scan and import documents in the image editing software such as Adobe Photoshop, if the software is TWAIN-compliant. Follow the steps below to scan with TWAIN-compliant software:

- 1 Make sure that the machine is connected to your computer and powered on.
- 2 Place a single document face down on the document glass, or load the documents face up into the document feeder (see "Loading originals" on page 54).
- 3 Open an application, such as Adobe Photoshop.
- 4 Click **File > Import**, and select the scanner device.
- 5 Set the scan options.
- 6 Scan and save your scanned image.

# Scan features

## Scanning using the WIA driver

Your machine supports the Windows Image Acquisition (WIA) driver for scanning images. WIA is one of the standard components provided by Microsoft Windows 7 and works with digital cameras and scanners. Unlike the TWAIN driver, the WIA driver allows you to scan and easily adjust images without using additional software:



The WIA driver works only on Windows OS with a USB port.

- 1 Make sure that the machine is connected to your computer and powered on.
- 2 Place a single document face down on the document glass, or load the documents face up into the document feeder (see "Loading originals" on page 54).
- 3 Click **Start > Control Panel > Hardware and Sound > Devices and Printers**.
- 4 Right-click on device driver icon in **Printers and Faxes > Start Scan**.
- 5 **New Scan** application appears.
- 6 Choose your scanning preferences and click **Preview** to see how your preferences affect the picture.
- 7 Scan and save your scanned image.

## Scanning with Samsung Easy Document Creator

Samsung Easy Document Creator is an application to help users scan, compile, and save documents in multiple formats, including .epub format.



- Available for Windows and Mac OS users only.
- Windows XP Service Pack 3 or higher and Internet Explorer 6.0 or higher is the minimum requirement for Samsung Easy Document Creator.
- Samsung Easy Document Creator is installed automatically when you install the machine software (see "Using Samsung Easy Document Creator" on page 305).

- 1 Place a single document face down on the document glass, or load the documents face up into the document feeder (see "Loading originals" on page 54).
- 2 From the **Start** menu select **Programs** or **All Programs > Samsung Printers**.  
For Mac, open the **Applications** folder > **Samsung** folder > **Samsung Easy Document Creator**.
- 3 Click **Samsung Easy Document Creator**.
- 4 Click **Scan** from the home screen.

# Scan features

- 5 Select the type of scanning or a favorites and then make adjustments to the image.
- 6 Click **Scan** to scan a final image or **Prescan** to get another preview image.
- 7 Press **Send** to save the scanned image.
- 8 Select the option you want.
- 9 Press **OK**.



Click the **Help** (?) button from the window, and then click on any option you want to know about.

## Mac scanning

You can scan documents using **Image Capture** program. Mac OS X offers **Image Capture** program.

## Scanning with network

- 1 Make sure that your machine is connected to a network.
- 2 Place a single document face down on the document glass, or load the documents face up into the document feeder (see "Loading originals" on page 54).
- 3 Open the **Applications** folder and run **Image Capture**.
- 4 Select your device below **SHARED**.
- 5 Set the scan options on this program.
- 6 Scan and save your scanned image.



- If scanning does not operate in Image Capture, update Mac OS to the latest version.
- For more information, refer to the **Image Capture**'s help.
- You can also scan using TWAIN-compliant software, such as Adobe Photoshop.
- You can scan using **Samsung Easy Document Creator** software. Open the **Applications** folder > **Samsung** folder > **Samsung Easy Document Creator**.



# Scan features

## Linux scanning

### Scanning

---

- 1 Make sure that the machine is connected to your computer and powered on.
- 2 Launch a scan application such as xsane or simple-scan (If it's not installed, please install it manually to use scan features. For example, you may use "yum install xsane" for rpm package systems and "apt-get install xsane" for deb package systems to install xsane).
- 3 Select your device from the list and set the scan options to apply.
- 4 Click the **Scan** button.

# Fax features



- For basic faxing features, refer to the Basic Guide (see "Basic faxing" on page 70).
- This function is not supported for C306xND (see "Control panel overview" on page 21).

## Automatic redialing

When the number you have dialed is busy or there is no answer when you send a fax, the machine automatically redials the number. The redial time depends on the country's factory default setting.

To change the time interval between redials and the number of redial attempts.

- 1 Press  (**Setup**) > **Machine Setup** > **Next** > **Fax Setup** on the touch screen.
- 2 Select **Redial Times** or **Redial Term** you want.
- 3 Select the option you want.

## Redialing the fax number

- 1 Press  (**Redial/Pause**) button on the control panel.
- 2 Select the fax number you want.  
Ten recently sent fax numbers with ten received Caller IDs are shown.
- 3 When an original is loaded in the document feeder, the machine starts to scan and automatically begins to send.  
If an original is placed on the scanner glass, select **Yes** to add another page. Load another original and press **OK**. When you have finished, select **No** when **Another Page?** appears.

## Confirming a transmission

When the last page of your original has been sent successfully, the machine beeps and returns to ready mode.

When something goes wrong while sending your fax, an error message appears on the display. If you receive an error message, press  (**Stop/Clear** or **Stop**) to clear the message and try to send the fax again.



You can set your machine to print a confirmation report automatically each time sending a fax is completed. Press  (**Setup**) > **Machine Setup** > **Next** > **Fax Setup** > **Fax Confirmation** on the touch screen.

# Fax features

## Sending a fax from the computer



- This feature may not be available depending on model or optional goods (see "Features by model" on page 7).

You can send a fax from your computer without going to the machine.

To send a fax from your computer, the **Samsung Network PC Fax** program must be installed.

- 1 Open the document to be sent.
- 2 Select **Print** from the **File** menu.  
The **Print** window will be displayed. It may look slightly different depending on your application.
- 3 Select **Samsung Network PC Fax** from the **Print** window
- 4 Click **Print** or **OK**.
- 5 Enter the recipients' numbers and select the option



- Select the **Help** menu or click the button from the window and click on any option you want to know about.

- 6 Click **Send**.

## Sending a fax manually using an extension telephone

- 1 Place a single document face down on the document glass, or load the documents face up into the document feeder (see "Loading originals" on page 54).
- 2 Press (**Fax**) on the touch screen.
- 3 Adjust the resolution and the darkness to suit your fax needs.
- 4 Pick up the receiver of the extension telephone.
- 5 When you hear the dial tone, dial a fax number using the extension telephone.
- 6 Press (**Start**) on the control panel when you hear a high-pitched fax signal from the extension telephone.

## Delaying a fax transmission



You can set your machine to send a fax at a later time when you will not be present. You cannot send a color fax using this feature.

# Fax features



- 1 Place a single document face down on the document glass, or load the documents face up into the document feeder (see "Loading originals" on page 54).
- 2 Press  (**Fax**) > **Delayed Send** > **Next** on the touch screen.
- 3 Enter the job name and the time > **Next** > press **Direct Input** or **Fax List** > enter the fax number using number keypad.

 If you set a time earlier than the current time, the fax will be sent at that time on the following day.

- 4 The original is scanned into memory before transmission. The machine returns to ready mode. The display reminds you that you are in ready mode and that a delayed fax is set.

 You can check the list of delayed fax jobs. Press  (**Setup**) > **Machine Setup** > **Next** > **Reports** > **Fax Schedule Jobs** on the touch screen.



## Canceling a reserved fax job

- 1 Press  (**Job Status**) > **Current Job** > **Next** on the touch screen.
- 2 Select the fax job you want and press the  (cancel) icon.
- 3 Press **Yes** when the confirmation windows appears.
- 4 Press the  (Home) icon to return to ready mode.

## Forwarding a sent fax to another destination

You can set the machine to forward the received or sent fax to other destination by a fax, an email or a server. If you are out of office but have to receive the fax, this feature may be useful.

-  When you forward a fax by an email, you must first set the mail server and IP address in SyncThru™ Web Service (see "SyncThru™ Web Service" on page 296).
- Though you sent or received a color fax, the data is forwarded in grayscale.

- 1 Place a single document face down on the document glass, or load the documents face up into the document feeder (see "Loading originals" on page 54).
- 2 Press  (**Setup**) > **Machine Setup** > **Next** > **Fax Setup** > **Send Forward** > **Forward to Fax**, **Forward to Email** or **Forward to Server** on the touch screen.
- 3 Turn this option "**On**" and then enter the forward number.
- 4 Press the  (Home) icon to return to ready mode. Subsequent sent faxes will be forwarded to the specified fax machine.



# Fax features

## Forwarding a received fax

You can set the machine to forward the received or sent fax to other destination by a fax, an email or a server. If you are out of office but have to receive the fax, this feature may be useful.



Though you sent or received a color fax, the data is forwarded in grayscale.

- 1 Press  (**Setup**) > **Machine Setup** > **Next** > **Fax Setup** > **Receive Forward** > **Forward to Fax**, **Forward to PC**, **Forward to Email** or **Forward to Server** on the touch screen.
- 2 Turn this option "**On**" and then enter the forward number.
- 3 Enter the starting time and ending time, then press **OK**.
- 4 Press the  (Home) icon to return to ready mode.  
Subsequent sent faxes will be forwarded to the specified fax machine.

## Sending faxes on both sides of paper



- This is available only when you load originals into the document feeder.
- Some menus may not appear on the display depending on options or models. If so, it is not applicable to your machine.
- This feature may not be available depending on model or optional goods (see "Features by model" on page 7).

- 1 Place a single document face down on the document glass, or load the documents face up into the document feeder (see "Loading originals" on page 54).
- 2 Press  (**Fax**) > select the fax menu you want > **Next** > select **Duplex** from the sub-menus > on the touch screen.
  - **1 Sided:** For originals that are printed on one side only.
  - **2 Sided:** For originals that are printed on both sides.
  - **2 Sided Rotated:** For originals that are printed on both sides, but the back is rotated 180°.



To use **2 Sided** and **2 Sided, Rotated**, load the originals on the DADF. If the machine cannot detect the original on the DADF, it automatically changes the option to **1 Sided**.

- 3 Press  (Back) to save the selection.

# Fax features

## Receiving a fax in the computer





- This feature may not be available depending on model or optional goods (see "Features by model" on page 7).
- To use this feature, set the option on the control panel:

Press  (**Setup**) > **Machine Setup** > **Next** > **Fax Setup** > **Receive Forward** > **Forward to PC** > **Forward** on the touch screen.

- 1 Open the Samsung Easy Printer Manager.
- 2 Select the appropriate machine from the **Printer List**.
- 3 Select **Fax to PC Settings** menu.
- 4 Use **Enable Fax Receiving from Device** to change the fax settings.
- 5 Press **Save** > **OK**.

## Changing the receive modes

- 1 Press  (**Setup**) > **Machine Setup** > **Next** > **Fax Setup** > **Receive Mode** on the touch screen.
- 2 Select the option you want.
  - **Fax:** Answers an incoming fax call and immediately goes into the fax reception mode.
  - **Tel:** Receives a fax by pressing  (**Fax**) > **On Hook Dial** and then  (**Start**) button.
  - **Ans/Fax:** Is for when an answering machine is attached to your machine. Your machine answers an incoming call, and the caller can leave a message on the answering machine. If the fax machine senses a fax tone on the line, the machine automatically switches to Fax mode to receive the fax.



To use the **Ans/Fax** mode, attach an answering machine to the EXT socket on the back of your machine.

- **DRPD:** You can receive a call using the Distinctive Ring Pattern Detection (DRPD) feature. Distinctive Ring is a telephone company service which enables an user to use a single telephone line to answer several different telephone numbers. For further details, see "Receiving faxes using DRPD mode" on page 292.

# Fax features



This setting may not be available depending on your country.



3

Press  (Back) to save the selection.

4

Press the  (Home) icon to return to ready mode.

## Receiving manually in Tel mode

You can receive a fax call by pressing  (**Fax**) > **On Hook Dial** and then pressing  (**Start**) when you hear a fax tone. If your machine has a handset, you can answer calls using the handset (see "Features by model" on page 7).

## Receiving in Answering Machine/Fax mode

To use this mode, you must attach an answering machine to the **EXT.** socket on the back of your machine. If the caller leaves a message, the answering machine stores the message. If your machine detects a fax tone on the line, it automatically starts to receive the fax.



- If you have set your machine to this mode and your answering machine is switched off, or no answering machine is connected to **EXT.** socket, your machine automatically goes into Fax mode after a predefined number of rings.
- If the answering machine has a user-selectable ring counter, set the machine to answer incoming calls within 1 ring.
- If the machine is in Tel mode, disconnect or switch off the answering machine with the fax machine. Otherwise, the outgoing message from the answering machine will interrupt your phone conversation.

## Receiving faxes with an extension telephone

When you are using an extension telephone connected to the **EXT.** socket, you can receive a fax from someone you are talking to on the extension telephone, without going to the fax machine.

When you receive a call on the extension phone and hear fax tones, press the keys **\*9\*** on the extension phone. The machine receives the fax.

**\*9\*** is the remote receive code preset at the factory. The first and the last asterisks are fixed, but you can change the middle number to whatever you want.



While you are talking over the telephone connected to the **EXT.** socket, copy and scan features are not available.

# Fax features

## Receiving faxes using DRPD mode

This setting may not be available depending on your country. Distinctive Ring is a telephone company service which enables an user to use a single telephone line to answer several different telephone numbers. This feature is often used by answering services who answer telephones for many different clients and need to know which number someone is calling in on to properly answer the phone.



This setting may not be available depending on your country.

- 1 Press  (**Setup**) > **Machine Setup** > **Next** > **Fax Setup** > **Receive Mode** > **DRPD** on the touch screen.
- 2 Call your fax number from another telephone.
- 3 When your machine begins to ring, do not answer the call. The machine requires several rings to learn the pattern.  
When the machine completes learning, the display shows **Completed DRPD Setup**. If the DRPD setup fails, **Error DRPD Ring** appears.
- 4 Press **OK** when DRPD appears and start over from step 2.



- DRPD must be set up again if you re-assign your fax number, or connect the machine to another telephone line.
- After DRPD has been set up, call your fax number again to verify that the machine answers with a fax tone. Then have a call placed to a different number assigned to that same line to be sure the call is forwarded to the extension telephone or answering machine plugged into the EXT socket.

## Receiving in secure receiving mode

You may need to prevent your received faxes from being accessed by unauthorized people. Turn on secure receiving mode, then all incoming faxes go into memory. You can print the incoming faxes by entering the password.



To use the secure receiving mode, activate the menu from  (**Setup**) > **Machine Setup** > **Next** > **Fax Setup** > **Secure Receive** on the touch screen.

## Printing received faxes

- 1 Press  (**Setup**) > **Machine Setup** > **Next** > **Fax Setup** > **Secure Receive** > **Print** on the touch screen.
- 2 Enter a four-digit password.
- 3 The machine prints all of the faxes stored in memory.



# Using shared folder features

This feature allows you to use the machine's memory as a shared folder. The advantage of this feature is that you can conveniently use the shared folder through your computer's window.



- This feature may not be available depending on model or optional goods (see "Features by model" on page 7).
- You can use this feature in the models that have a mass storage device (see "Variety feature" on page 8).
- The administrator can set the ID and password to restrict the user's access and also set the maximum number of simultaneous users.

## Creating a shared folder

- 1 Open the Windows Explore window from the computer.
- 2 Enter the printer's **WW[ip address]** (example: WW169.254.133.42) in the address field, and press the Enter key or click **Go**.
- 3 Create a new folder under **nfsroot** directory.

## Using the shared folder

You can use the shared folder exactly like the normal computer. Create, edit and delete the folder or file as a normal Windows folder. You also store the scanned data in the shared folder. You can directly print files stored on a the shared folder. You can print TIFF, JPEG and PRN files.



# 5. Useful Management Tools

This chapter introduces management tools provided to help you make full use of your machine.

- **Accessing management tools** 295
- **SyncThru™ Web Service** 296
- **Easy Capture Manager** 302
- **Samsung AnyWeb Print** 303
- **Easy Eco Driver** 304
- **Using Samsung Easy Document Creator** 305
- **Using Samsung Printer Center** 306
- **Using Samsung Easy Printer Manager** 309
- **Using Samsung Printer Status** 312
- **Using Samsung Printer Experience** 314



# Accessing management tools

Samsung provides a variety of management tools for Samsung printers.

- 1 Make sure that the machine is connected to your computer and powered on.
- 2 From the **Start** menu, select **Programs** or **All Programs** > **Samsung Printers**.
  - For Windows 8  
From the **Charms**, select **Search** > **Apps** > **Samsung Printers**.
  - Windows 10 / Windows Server 2016  
From task bar, type in **Samsung Printers** in **Search** input area. Press the Enter key.  
OR  
From the **Start** () icon, select **All apps** > **Samsung Printers**.
- 3 Find **Samsung Printers**.
- 4 Under **Samsung Printers**, you can see installed management tools.
- 5 Click the management tool you want to use.



- After installing the driver, for some management tools, you can access them directly from the **Start** menu > **Programs** or **All Programs**.
- For Windows 8, after installing the driver, for some management tools, you can access them directly from the **Start** screen by clicking on the corresponding tile.

# SyncThru™ Web Service

This chapter gives you step-by-step instructions for setting up the network environment through SyncThru™ Web Service.



- Internet Explorer® 8.0 or higher is the minimum requirement for SyncThru™ Web Service.
- Some menus may not appear on the display screen depending on the settings or models. If so, it is not applicable to your machine.

## What is SyncThru™ Web Service?

If you have connected your machine to a network and set up TCP/IP network parameters correctly, you can manage the machine via SyncThru™ Web Service. Use SyncThru™ Web Service to:

- View the machine's device information and check its current status.
- Change TCP/IP parameters and set up other network parameters.
- Change the printer preference.
- Set the email notifications advising of the machine's status.
- Get support for using the machine.
- Upgrade machine software.

## Required web browser

You need one of the following web browsers to use SyncThru™ Web Service.

- Internet Explorer® 8.0 or higher
- Chrome 27.0 or higher
- FireFox 21.0 or higher
- Safari 5.9.1 or higher

## Connecting to SyncThru™ Web Service

### IPv4 supported web browser

- 1 Start a web browser, such as Internet Explorer®, that supports IPv4 addressing as a URL.

Enter the machine's IP address (<http://xxx.xxx.xxx.xxx>) in the address field and press the Enter key or click **Go**.



You can get the machine's IP address from the machine report (see "Printing a network configuration report" on page 164).

- 2 Your machine's SyncThru™ Web Service website opens.

# SyncThru™ Web Service

## IPv6 supported web browser

- 1 Start a web browser, such as Internet Explorer®, that supports IPv6 addressing as a URL.
- 2 Select one of the IPv6 addresses (**Stateless Address**, **Stateful Address**, **Manual Address**) from **Network Configuration Report**.



You can get the machine's IPv6 address from the machine report (see "Printing a network configuration report" on page 164).

- 3 Enter the IPv6 addresses (eg., `http://[3ffe:10:88:194:213:77ff:fe82:75b]`).



The address must be enclosed in '[' ]' brackets.

- 4 Your machine's SyncThru™ Web Service website opens.

## Accessing SyncThru™ Web Service

- 1 Access a web browser, such as Internet Explorer, from Windows.  
Enter the machine IP address of your printer (`http://xxx.xxx.xxx.xxx`) in the address field and press the Enter key or click **Go**.
- 2 Your machine's embedded website opens.

## Logging into SyncThru™ Web Service

Before configuring options in SyncThru™ Web Service, you need to log-in as an administrator. You can still use SyncThru™ Web Service without logging in but you won't have access to **Settings** tab and **Security** tab.

- 1 Click **Login** on the upper right of the SyncThru™ Web Service website.
- 2 Type in the **ID** and **Password** then click **Login**. We recommend you to change the default password for security reasons.
  - **ID: admin**
  - **Password: sec00000**

## SyncThru™ Web Service overview

# SyncThru™ Web Service

## Information tab

---

This tab gives you general information about your machine. You can check things, such as the machine's status, supplies' status, count information, network information, and more. You can also print reports, such as configuration page.

- **Active Alerts:** You can check the current alerts in the machine. Use this information to troubleshoot machine errors.
- **Supplies:** You can check the supplies' information. For toner cartridge, supplies' status is displayed with a visual graph showing you the amount of each supply left. Page counts are also available which can help you predict when to change the supplies. This feature is also available from the machine.
- **Usage Counters:** You can check the billing information and usage counter of the machine. This feature is also available from the machine.
- **Current Settings:** Shows the current settings of the machine and network.
  - **Machine Information:** Shows the current machine settings.
  - **Network Information:** Shows the current network settings. Use this page as a reference and change the necessary settings needed for using the network.
- **Security Information:** Shows the current security settings of the machine and network.
- **Print Information:** You can print all the reports provided by your machine. You can use these reports to help you maintain your machine. This feature is also available in the machine.

## Address book tab

---

You can manage the address book. This feature is also available from the machine (see "Setting up the fax address book" on page 255).

- **Individual:** You can manage individual entries in the address book.
- **Group:** You can manage group address books.

## Settings tab

---

Settings tab has sub menus, **Machine Settings** and **Network Settings**. You cannot view or access this tab if you do not log-in as an administrator (see "Logging into SyncThru™ Web Service" on page 297).

- **Machine Settings:** You can set machine settings.
  - **System:** You can set machine related settings.
  - **Printer:** You can set print related settings such as darkness or adjust the background. This feature is also available from the machine.
  - **Copy:** You can set copy related settings such as darkness or adjusting the background.
  - **Fax:** You can set fax related settings such as fax number or redial times. This feature is also available from the machine.
  - **Scan:** You can set scan related settings. This feature is also available from the machine.

# SyncThru™ Web Service

- **Email Notification:** When an error occurs or the supplies are running out, the machine sends a notification to the administrator via email. You can set whether to use this feature or not. You can also select which alerts to receive and when.
- **Network Settings:** You can set up the network environment to use your machine as a network machine. You can also set the settings from the machine. Refer to the network setup chapter.
  - **General:** You can set general machine information to use in the network and set ethernet settings. This feature is also available from the machine.
  - TCP/IPv4, TCP/IPv6, Raw TCP/IP, LPR/LPD, IPP, Telnet, WSD, SLP, UPNP, mDNS, CIFS (Shared Folder), SNMPv1/v2, SNMPv3, FTP Print Server, AirPrint, ThinPrint®, Google Cloud Print: You can set protocol settings.
  - **Outgoing Mail Server (SMTP):** You can set server settings for outgoing emails. If this setting is not configured, you cannot use scan to email feature. Outgoing emails will be sent through SMTP server you set here.
  - **HTTP:** You can allow or block users from accessing the SyncThru™ Web Service.
  - **Proxy:** You can set proxy settings and enable authentication.
  - **Restore Default:** Clicking the **Clear** button under the **Restore Default** section will clear security and network configurations. Restoring the settings will take effect after the system is rebooted.

## Security tab

---

The security tab has **System Security**, **Network Security**, **User Access Control** and **System Log**. You cannot access this tab if you do not log-in as an administrator (see "Logging into SyncThru™ Web Service" on page 297).

- **System Security:** From the SyncThru™ Web Service, select the **Security** tab > **System Security**.
  - **System Administrator:** Enter the system administrator's information. The machine sends email notification to the email address set here. This feature is also available from the machine.
  - **Feature Management:** Specifies the services, PC application security, physical ports, and network protocol features to use. Select the features to use, and then click **Apply**.
  - **Information Hiding:** Specifies which information to hide. Select the amount of information that you want to hide, and then click **Apply**.
  - **Restart Device:** You can reboot your machine. Click the **Restart Now** button to reboot.
- **Network Security:** From the SyncThru™ Web Service, select the **Security** tab > **Network Security**.
  - **Digital Certificate:** You can manage digital certificates. A digital certificate is an electronic certificate that verifies the secure association between communication nodes. You need to add the certificate for SSL communication.

# SyncThru™ Web Service

- **Secure Connection:** You can enable or disable secure connection to use more enhanced secure network channel. For secure communication, using the **Secure Connection** feature is recommended.
- **SNMPv3:** You can set SNMPv3.
- **IP Security:** You can set IP security settings.
- **IP/MAC Filtering:** You can set filtering options for IP and MAC addresses. If the administrator does not add a filtering rule for IPv4, IPv6, and MAC addresses, nothing is filtered. If the administrator has added a filtering rule, filtering will be applied to the entered IPv4, IPv6, and MAC addresses.
  - **IPv4 Filtering:** You can enable/disable IPv4 filtering as well as manage filtering rules.
  - **IPv6 Filtering:** You can enable/disable IPv6 filtering as well as manage filtering rules.
  - **MAC Filtering:** You can enable/disable Mac filtering as well as manage filtering rules.
- **802.1x(External):** You can enable/disable 802.1x Security as well as manage filtering rules.
- **External Authentication Server:** Set the servers for authentication.
- **User Access Control:** You can restrict users from accessing the machine or application. You can also give specific permission for user to only use certain feature of the machine. For example, you can allow user A to only use print feature. In this case, user A will not be able to scan, copy or fax with the machine.
  - **Authentication:** You can choose the authentication method for user authentication. Select a mode and click on the **Options** button.
  - **Authorization (Giving rights):** You can give permissions to a user to only use certain features of the machine.
    - **Authority Management:** You can give different rights to different users. For example, you can allow user A to use all the machine's functions while giving user B only the right to print.
    - **External User Authority:** Set the servers for authentication.
  - **Accounting:** You can manage accounts.
- **User profile:** You can store user information on the machine's hard drive or NFC. You can use this feature to manage the users using the machine. You can also group the users and manage them as a group. You can make a maximum of 500 individual users and 200 user groups. User identified by user ID and password are allowed to modify their password. They are allowed to view all of their profile information. When it comes to the role, users are allowed to see only the role they belong to but not its permissions.



# SyncThru™ Web Service

- **System Log:** You can keep logs of events that have happened in the machine. The administrator can record and manage the machine usage information by keeping the system log files. The system log files are stored on the machine's mass storage device (hard disk), and when it is full, it will erase old data. Export and save the important audit data separately using the exporting feature.
  - **Log configuration:** You can enable or disable keeping logs. You can also backup log files by periods and transfer to a repository server.
  - **Log Viewer:** You can view, delete, and search log files.

## Maintenance tab

---

This tab allows you to maintain your machine by upgrading firmware, managing applications, and setting contact information for sending emails. You can also connect to the Samsung website or download manuals and drivers by selecting the **Link** menu.

- **Firmware Upgrade:** You can check the firmware version used in the machine. Check the version and update it if necessary.
- **Application Management:** You can add or delete applications/license. If you add an application, you need to activate the license of the installed application. Some applications may not have a license.
- **Contact Information:** You can view contact information.
- **Link:** You can view links to useful websites where you can:
  - view product information and get support (Samsung website).
  - download manuals and drivers.

- order supplies.
- register your machine on-line.
- **Samsung MIB Version:** The version number of the MIB(Management Information Base).
- **License Management: License Management** provides settings managing the licenses for installed applications.
- **Cloning:** The machine prints multiple original images on a single page. The number of images is automatically determined by the original image and the paper size. You can enable or disable the clone menu.
- **Wi-Fi Interface:** You can enable or disable the Wi-Fi menu.

# Easy Capture Manager



- Available for Windows OS users only.
- This feature may not be available depending on model or optional goods (see "Software" on page 7).

Capture your screen and launch Easy Capture Manager by simply pressing the Print Screen key on the keyboard. Now you can easily print your captured screen as captured or edited.

# Samsung AnyWeb Print



- Available for Windows OS users only.
- This feature may not be available depending on model or optional goods (see "Software" on page 7).

This tool helps you screen-capture, preview, scrap, and print Windows Internet Explorer pages more easily, than when you use an ordinary program.

Download the software from the Samsung website then unpack and install it: (<http://www.samsung.com> > find your product > Support or Downloads).

# Easy Eco Driver

-  Available for Windows OS users only (see "Software" on page 7).
- To use the Easy Eco Driver features, the **Eco Driver Pack** must be installed.

With the Easy Eco Driver, you can apply Eco features to save paper and toner before printing.

Easy Eco Driver also allows you simple editing such as removing images and texts, and more. You can save frequently used settings as a favorite (preset).

## How to use:

- 1 Open a document to print.
- 2 Open printing preference window.
- 3 From the **Favorites** tab, select **Eco Preview Printing**.
- 4 Click **OK > Print** in the window. A preview window appears.
- 5 Select the options you want to apply to the document.

You can see the preview of the applied features.

- 6 Click **Print**.

-  If you want to run Easy Eco Driver every time you print, check **Start Easy Eco Driver before printing job** checkbox in the **Basic** tab of the printing preference window.
- To use this feature on Stylish User Interface, click **Samsung Printer Center > Device Options** and then select **Stylish User Interface** (see "Using Samsung Printer Center" on page 306).

# Using Samsung Easy Document Creator



- Available for Windows and Mac OS users only.
- Windows® XP Service Pack 3 or higher and Internet Explorer 6.0 or higher is the minimum requirement for Samsung Easy Document Creator.

Samsung Easy Document Creator is an application to help users scan, compile, and save documents in multiple formats, including .epub format. These documents can be shared via social networking sites or fax. Whether you're a student needing to organize research from the library or a stay-at-home mom sharing scanned pictures from last year's birthday party, Samsung Easy Document Creator will provide you with the necessary tools.

The Samsung Easy Document Creator provides features mentioned below:

- **Scan:** Use for scanning pictures or documents.
- **Text Converting Scan**(Windows only): Use for scanning documents that need to be saved in an editable text format.
- **Document Conversion:** Provides the ability to convert existing files into multiple formats.
- **Fax:** Provides the ability to directly fax a document from Easy Document Creator if the Samsung Network PC fax driver is installed.

# Using Samsung Printer Center



Available for Windows users only.

The **Samsung Printer Center** allows you to manage all the printer drivers installed on your computer from a single integrated application. You can use the **Samsung Printer Center** to add and remove printer drivers, check the status of printers, update printer software, and configure printer driver settings.

## Understanding Samsung Printer Center

To open the program:

### For Windows,

Select **Start > Programs** or **All Programs > Samsung Printers > Samsung Printer Center**.

- For Windows 8  
From the **Charms**, select **Search > Apps > Samsung Printers > Samsung Printer Center**.
- Windows 10 / Windows Server 2016  
From task bar, type in **Samsung Printers** in **Search** input area. Press the Enter key and then select **Samsung Printer Center**.

OR

From the **Start** () icon, select **All apps > Samsung Printers > Samsung Printer Center**.

## Printers tab



The screenshot may differ depending on operating system, model, or options.

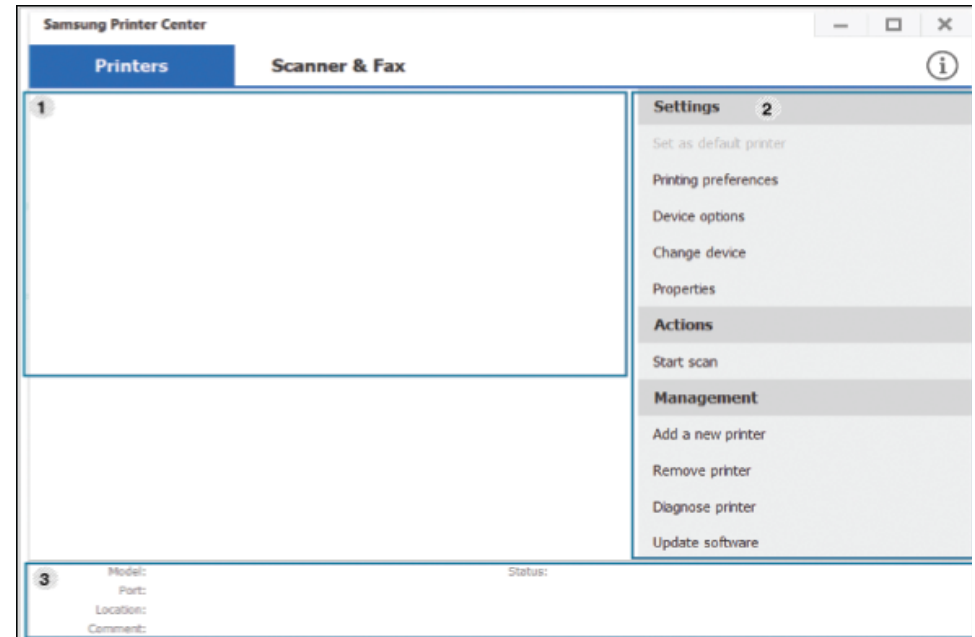

1	<b>Printer list</b>	Displays the printer drivers installed on your computer. To add a printer driver to the list, click the  button.
---	---------------------	---

# Using Samsung Printer Center

## Quick links

Displays links to various printer driver management functions. The quick links in the **Printers** tab link to the following functions:

- **Settings:** Allows you to configure the settings for individual printer driver.
  - **Set as default printer:** Sets the selected printer driver as the default printer. If the selected printer driver is already set as the default printer, then this option is not activated.
  - **Printing preferences:** Allows you to configure the default print settings.
  - **Device options:** Allows you to configure advanced options, such as the settings for optional devices and additional features.



The option allows you to modify the **Printer Status** and **Stylish User Interface** settings.

- **Change device:** Allows you to change the device into another device.
- **Properties:** Allows you to configure the printer driver properties, such as the name of the printer driver and its location, or add comments about the printer driver.
- **Actions:** Allows you to use the scan feature (this option is enabled only if the selected device supports the scan feature).
- **Management:** Allows you to manage the devices registered in the program.
  - **Add a new printer / Remove printer:** Adds a new device or removes an existing device.
  - **Diagnose printer:** Diagnoses problems in the selected device and suggests solutions.
  - **Update software:** Downloads and applies the applicable software updates.

3

## Printer information

Provides general information about the selected device, such as its model, IP address, port number, and status.

## Scanner & Fax Tab



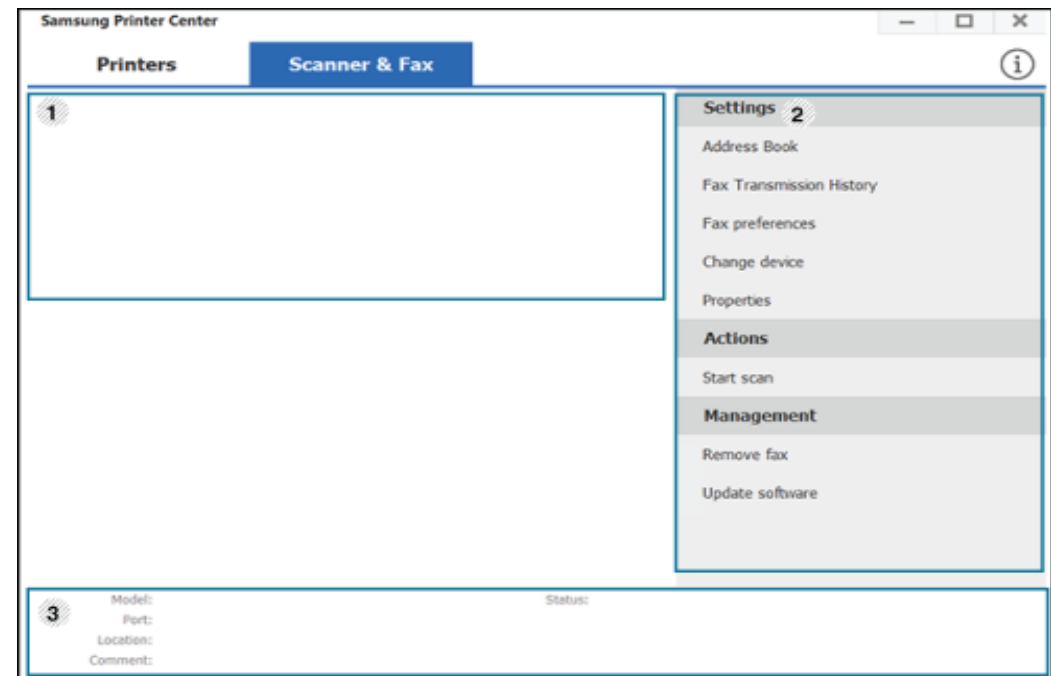

- The screenshot may differ depending on operating system, model, or option.
- **Available for multifunction products only.**



2

# Using Samsung Printer Center

1	<b>Printer list</b>	Displays the fax and scanner driver installed on your computer. To add a fax or scanner driver to the list, click the  ( <b>Add Fax</b> ) or  ( <b>Add Scanner</b> ) button.
2	<b>Quick links</b>	Displays links to the functions available for managing fax or scanner drivers. The quick links in the <b>Scanner &amp; Fax</b> tab offer the following features:   To use this feature, the scanner driver and fax driver must be installed on the computer.  <ul style="list-style-type: none"><li>• <b>Settings:</b> Allows you to configure the settings for fax or scanner drivers.<ul style="list-style-type: none"><li>- <b>Address Book</b> (fax only): Opens the Address Book.</li><li>- <b>Fax Transmission History</b> (fax only): Opens the fax transmission history.</li><li>- <b>Fax preferences</b> (fax only): Allows you to configure the default fax settings.</li><li>- <b>Change device:</b> Allows you to change the devices into another device.</li><li>- <b>Properties:</b> Allows you to configure the properties of a device, such as location and add comments about the device.</li></ul></li><li>• <b>Actions:</b> Allows you to use the scan feature.</li><li>• <b>Management:</b> Allows you to manage the devices registered in the program.<ul style="list-style-type: none"><li>- <b>Remove fax</b> or <b>Remove scan:</b> Removes the selected fax or scan driver.</li><li>- <b>Update software:</b> Downloads and applies the applicable software updates.</li></ul></li></ul>
3	<b>Printer information</b>	Provides general information about the selected device, such as the model, IP address, port number, and machine status.



# Using Samsung Easy Printer Manager



- Available for Windows and Mac OS users only.
- For Windows, Internet Explorer 6.0 or higher is the minimum requirement for Samsung Easy Printer Manager.

Samsung Easy Printer Manager is an application that combines Samsung machine settings into one location. Samsung Easy Printer Manager combines device settings as well as printing environments, settings/actions and launching. All of these features provide a gateway to conveniently use your Samsung machine.

## Understanding Samsung Easy Printer Manager

To open the program:

**For Windows,**

Select **Start > Programs** or **All Programs > Samsung Printers > Samsung Easy Printer Manager**.

- For Windows 8

From the **Charms**, select **Search > Apps > Samsung Printers > Samsung Easy Printer Manager**.

- Windows 10 / Windows Server 2016

From task bar, type in **Samsung Printers** in **Search** input area. Press the Enter key and then select **Samsung Easy Printer Manager**.

OR

From the **Start** () icon, select **All apps > Samsung Printers > Samsung Easy Printer Manager**.

**For Mac,**

Open the **Applications** folder > **Samsung** folder > **Samsung Easy Printer Manager**.

The Samsung Easy Printer Manager interface is comprised of various basic sections as described in the table that follows:

# Using Samsung Easy Printer Manager

 The screenshot may differ depending on operating system, model, or option.

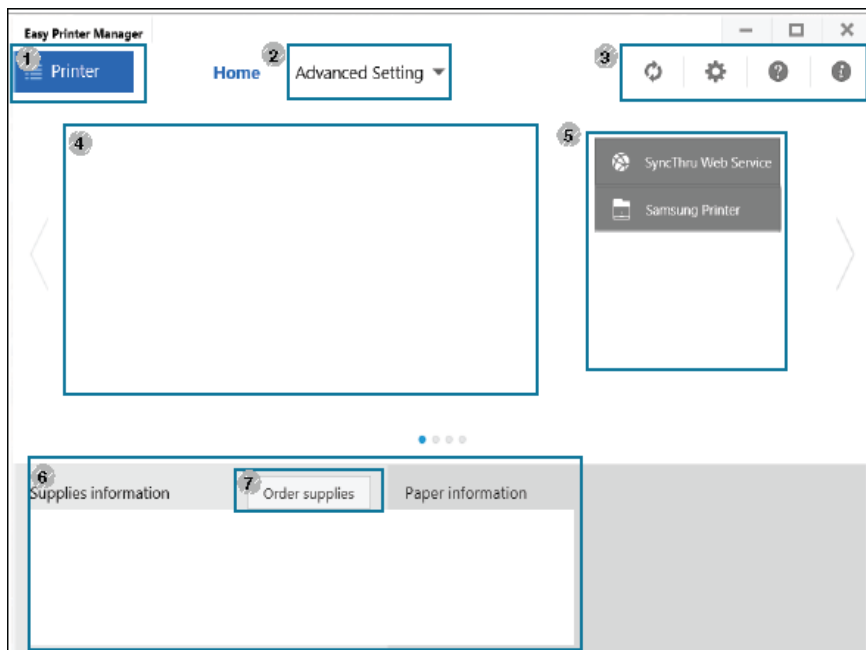

1	<b>Printer list</b>	The Printer list displays printers installed on your computer and network printers added by network discovery (Windows only).
---	---------------------	---

## 2 **Advanced Setting**

The advanced user interface is intended to be used by the person responsible for managing the network and machines.



 Some menus may not appear in the display depending on options or models. If so, it is not applicable to your machine.

- **Device Settings:** You can configure various machine settings such as machine setup, paper, layout, emulation, network, and print information.

 If you connect your machine to a network, the SyncThru™ Web Service icon is enabled.

- **Scan to PC Settings:** This menu includes settings to create or delete scan to PC profiles.
  - **Scan Activation:** Determines whether or not scanning is enabled on the device.
  - **Basic tab:** Contains settings related general scan and device settings.
- **Alert Settings (Windows only):** This menu includes settings related to error alerting.
  - **Printer Alert:** Provides settings related to when alerts will be received.
  - **Email Alert:** Provides options relating to receiving alerts via email.
  - **Alert History:** Provides a history of device and toner related alerts.

# Using Samsung Easy Printer Manager

3	<b>Application information</b>	Includes links for changing to the refresh, preference setting, help, and about.
4	<b>Printer information</b>	<p>This area gives you general information about your machine. You can check information, such as the machine's model name, IP address (or Port name), and machine status.</p> <div data-bbox="331 438 1097 638"> This button opens the <b>Troubleshooting Guide</b> when an error occurs. You can directly open the troubleshooting section in the user's guide.</div>
5	<b>Quick links</b>	<p>Displays <b>Quick links</b> to machine specific functions. This section also includes links to applications in the advanced settings.</p> <div data-bbox="331 813 1097 973"> If you connect your machine to a network, the SyncThru™ Web Service icon is enabled.</div>
6	<b>Contents area</b>	Displays information about the selected machine, remaining toner level, and paper. The information will vary based on the machine selected. Some machines do not have this feature.
7	<b>Order supplies</b>	Click on the <b>Order</b> button from the supply ordering window. You can order replacement toner cartridge(s) from online.



Select the **Help** menu or click the  button from the window and click on any option you want to know about.

# Using Samsung Printer Status

The Samsung Printer Status is a program that monitors and informs you the status of machine.



- The Samsung Printer Status window and its contents shown in this user's guide may differ depending on the machine or operating system in use.
- Check the operating system(s) that are compatible with your machine (see "System requirements" on page 136).
- Available for Windows OS users only.

## Samsung Printer Status overview

If an error occurs while operating, you can check the error from the Samsung Printer Status. Samsung Printer Status is installed automatically when you install the machine software.

You can also launch Samsung Printer Status manually. Go to the **Printing Preferences** and click the **Printer Status** button.

These icons appear on the Windows task bar:

Icon	Mean	Description
	Normal	The machine is in ready mode and experiencing no errors or warnings.

Icon	Mean	Description
	Warning	The machine is in a state where an error might occur in the future. For example, it might be in toner low status, which may lead to toner empty status.
	Error	The machine has at least one error.



The screenshot may differ depending on operating system, model, or option.

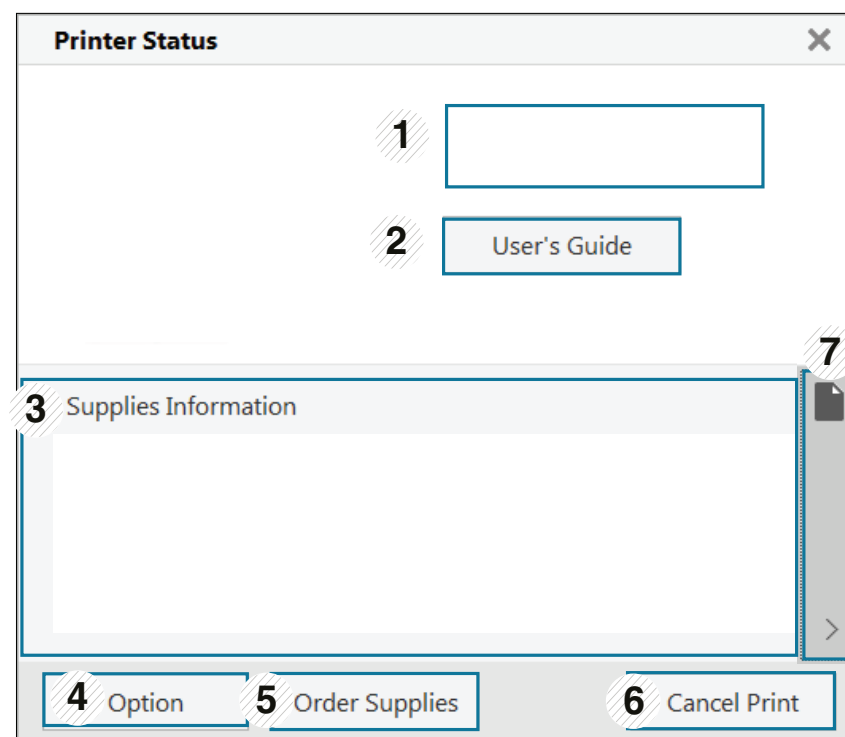

# Using Samsung Printer Status

1	<b>Device Information</b>	You can view the device information.
2	<b>User's Guide</b>	<p>You can view the online User's Guide.</p> <div style="border: 1px solid #ccc; padding: 5px; margin: 10px 0;">  This button opens the <b>Troubleshooting Guide</b> when an error occurs. You can directly open the troubleshooting section in the user's guide.         </div>
3	<b>Supplies Information</b>	You can view the percentage of toner remaining in each toner cartridge. The machine and the number of toner cartridge(s) shown in the above window may differ depending on the machine in use. Some machines do not have this feature.
4	<b>Option</b>	You can set printing job alert related settings.
5	<b>Order Supplies</b>	You can order replacement toner cartridge(s) from online.
6	<b>Cancel Print</b> or <b>Close</b>	<ul style="list-style-type: none"> <li>• <b>Cancel Print</b> : If print job is waiting in the print queue or printer, cancel all user's print jobs in the print queue or the printer.</li> <li>• <b>Close</b> : Depending on the status of the machine or the supported functions, the <b>Close</b> button may appear to close the status window.</li> </ul>

7	<b>Toner/Paper Information</b>	This button area for paper and toner info will be available based on the device.
---	--------------------------------	--

# Using Samsung Printer Experience

**Samsung Printer Experience** is a Samsung application that combines Samsung machine settings and machine management into one location. You can set device settings, order supplies, open troubleshooting guides, visit Samsung's website, and check connected machine information. This application will be automatically downloaded from the Windows **Store** if the machine is connected to a computer with an Internet connection.



Available for Windows 8 or higher users only.

## Understanding the Samsung Printer Experience

To open the application,

From the **Start** screen or **Start** (  ) icon, select the **Samsung Printer Experience** (  ) tile.

The **Samsung Printer Experience** interface comprises various useful features as described in the following table:



The screenshot may differ depending on operating system, model, or option.

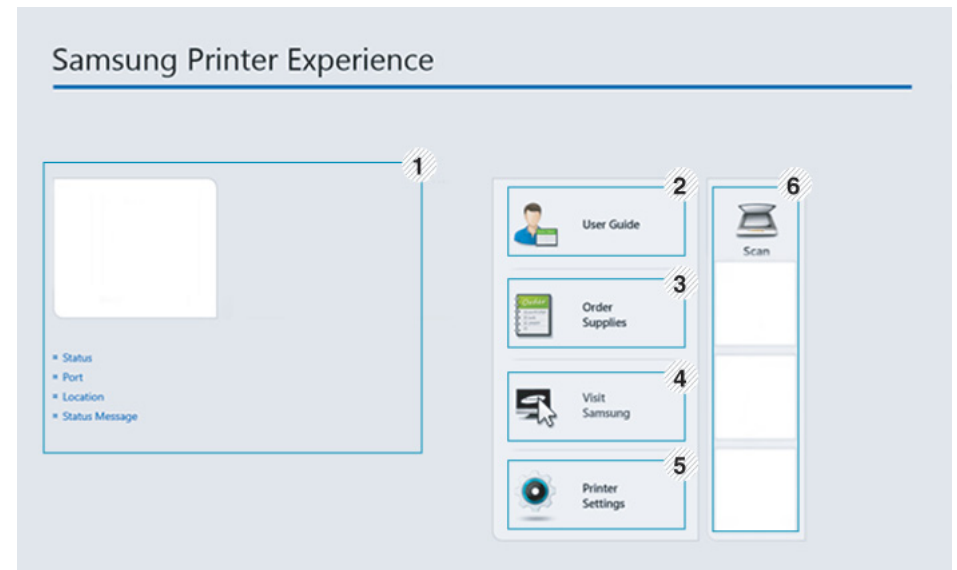

1	<b>Printer Information</b>	This area gives you general information about your machine. You can check information, such as the machine's status, location, IP address, and remaining toner level.
---	----------------------------	---

# Using Samsung Printer Experience

2	<b>User's Guide</b>	You can view the online User's Guide. You need to be connected to the Internet to use this feature.   This button opens the <b>Troubleshooting Guide</b> when an error occurs. You can directly open the troubleshooting section in the user's guide.
3	<b>Order Supplies</b>	Click on this button to order replacement toner cartridges online. You need to be connected to the Internet to use this feature.
4	<b>Visit Samsung</b>	Links to Samsung printer website. You need to be connected to the Internet to use this feature.
5	<b>Printer Settings</b>	You can configure various machine settings such as machine setup, paper, layout, emulation, networking, and print information through <b>SyncThru™ Web Service</b> . Your machine needs to be connected to a network. This button will be disabled if your machine is connected via USB cable.
6	<b>Device List &amp; Latest Scanned Image</b>	The scan list displays devices that supports <b>Samsung Printer Experience</b> . Under the device, you can see the latest scanned images. Your machine needs to be connected to a network to scan from here.  This section is for the users with multi-functional printers.

## Adding/Deleting Printers

If you do not have any printer added to the **Samsung Printer Experience**, or if you want to add/delete a printer, follow the instructions below.



You can only add/delete network connected printers.

## Adding a printer

- 1 Right-click the **Samsung Printer Experience** page and select **Settings**.
- 2 Select **Add Printer**
- 3 Select the printer you want to add.  
You can see the added printer.



If you see **+** mark, you can also click **+** mark to add printers.

# Using Samsung Printer Experience

## Deleting a printer

- 1 Right-click the **Samsung Printer Experience** page, and then click **Settings**.
- 2 Select **Remove Printer**.
- 3 Select the printer you want to delete.
- 4 Click **Yes**.  
You can see that the selected printer is removed from the screen.

## Printing

This section explains common printing tasks from the **Start** screen.



The screenshot may differ depending on operating system, model, or option.

## Basic printing

- 1 Open the document to print.
- 2 Select **Print** from the **File** menu.
- 3 Select your printer from the list
- 4 Select the printer settings, such as the number of copies and orientation.
- 5 Click the **Print** button to start the print job.

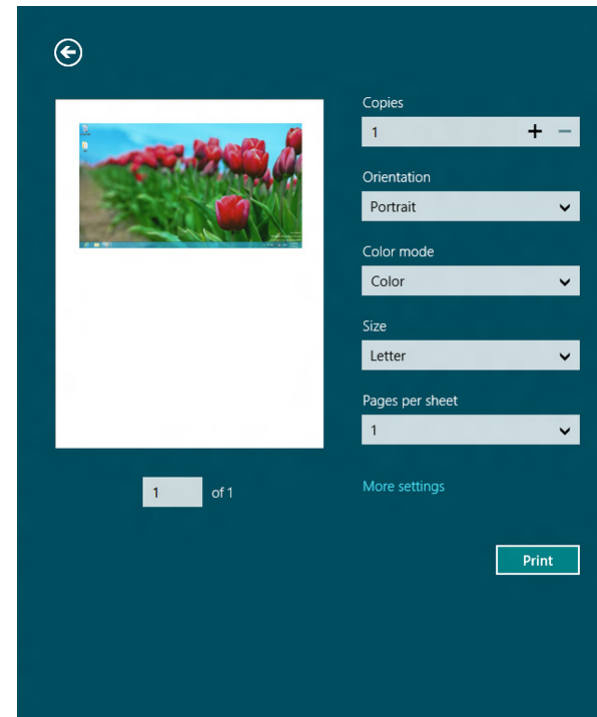





# Using Samsung Printer Experience

## Canceling a print job

If the printing job is waiting in the print queue or print spooler, cancel the job as follows:

- You can access this window by simply double-clicking the machine icon (  ) in the Windows task bar.
- You can also cancel the current job by pressing (  ) (**Stop**) button on the control panel.

## Opening more settings



The screen may appear somewhat different depending on the model or options.

You can set up more printing parameters.

- 1 Open the document you want to print.
- 2 Select **Print** from the **File** menu.
- 3 Select your printer from the list
- 4 Click **More settings**.

## Basic tab



### Basic

This option allows you to choose the basic printing settings such as copies, orientation, and document type.

### Eco settings

This option allows you to choose multiple pages per side to save media.

# Using Samsung Printer Experience

## Advanced tab

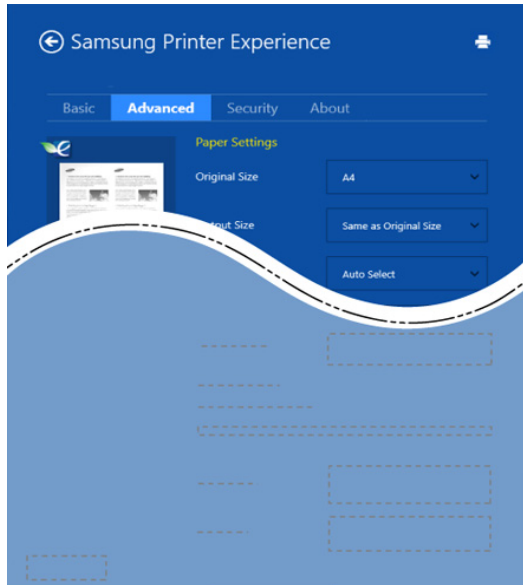

### Paper settings

This option allows you to set the basic paper handling specifications.

### Layout settings

This option allows you to set the various ways to layout your documents.

## Security tab



Some features may not be available depending on the model or options. If this tab is not shown or disabled, it means that these features are not supported.

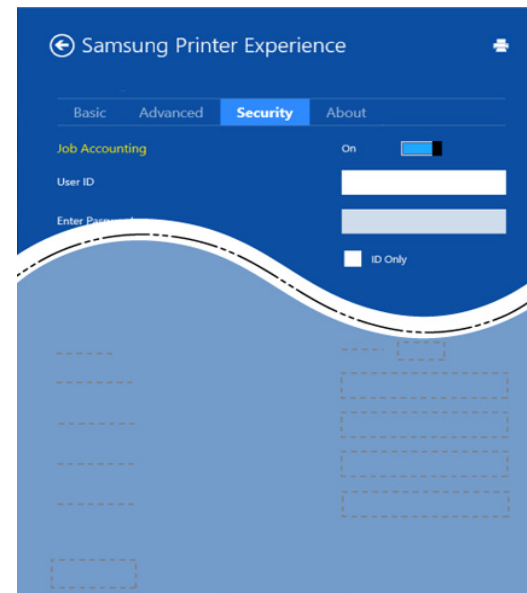

### Job Accounting

This option allows you to print with the given permission.

### Confidential Printing

This option is used for printing confidential documents. You need to enter a password to print using it.

# Using Samsung Printer Experience

## Using the sharing feature

**Samsung Printer Experience** allows you to print from other applications installed on the computer using the sharing feature.



This feature is only available for printing jpeg, bmp, tiff, gif, and png file formats.

- 1 Select the content you want to print from other application.
- 2 Click **Share** or press Window key + H.
- 3 Select the printer settings, such as the number of copies and orientation.
- 4 Click the **Print** button to start the print job.

## Scanning





This section is for the users with multi-functional printers.

Scanning with your machine lets you turn pictures and text into digital files that can be stored on your computer.

## Scanning from Samsung Printer Experience

The most frequently used printing menus are displayed for quick scanning.

- 1 Place a single document face down on the document glass, or load the documents face up into the document feeder.
- 2 Click the **Samsung Printer Experience** tile on the **Start** screen.
- 3 Click **Scan** (.
- 4 Set up the scanning parameters such as image type, document size, and resolution.
- 5 Click **Prescan** () to check the image.
- 6 Adjust the prescanned image with scanning operation functions such as rotate and mirror.
- 7 Click **Scan** () and save the image.



- When you place the originals in the ADF or RADF, **Prescan** () is not available.
- You can skip step 5, if the Prescan option is selected.



# 6. Troubleshooting

This chapter gives helpful information for what to do if you encounter an error.

- **Paper feeding problems** 321
- **Power and cable connecting problems** 322
- **Printing problems** 323
- **Printing quality problems** 327
- **Copying problems** 335
- **Scanning problems** 336
- **Faxing problems** 338
- **Operating system problems** 340



For errors that occur during the wireless software installation and settings, refer to the troubleshooting section in the wireless setting chapter (see "Troubleshooting for wireless network" on page 187).

# Paper feeding problems

Condition	Suggested solutions
<b>Paper jams during printing.</b>	Clear the paper jam.
<b>Paper sticks together.</b>	<ul style="list-style-type: none"><li>• Check the maximum paper capacity of the tray.</li><li>• Make sure that you are using the correct type of paper.</li><li>• Remove paper from the tray and flex or fan the paper.</li><li>• Humid conditions may cause some paper to stick together.</li></ul>
<b>Multiple sheets of paper do not feed.</b>	Different types of paper may be stacked in the tray. Load paper of only one type, size, and weight.
<b>Paper does not feed into the machine.</b>	<ul style="list-style-type: none"><li>• Remove any obstructions from inside the machine.</li><li>• Paper has not been loaded correctly. Remove paper from the tray and reload it correctly.</li><li>• There is too much paper in the tray. Remove excess paper from the tray.</li><li>• The paper is too thick. Use only paper that meets the specifications required by the machine.</li></ul>
<b>The paper keeps jamming.</b>	<ul style="list-style-type: none"><li>• There is too much paper in the tray. Remove excess paper from the tray. If you are printing on special materials, use the manual feeding in tray.</li><li>• An incorrect type of paper is being used. Use only paper that meets the specifications required by the machine.</li><li>• There may be debris inside the machine. Open the front cover and remove any debris.</li></ul>
<b>Envelopes skew or fail to feed correctly.</b>	Ensure that the paper guides are against both sides of the envelopes.

# Power and cable connecting problems

Reboot the power. If the problem persists, please call for service.

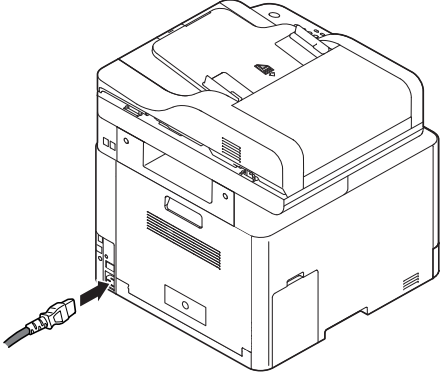
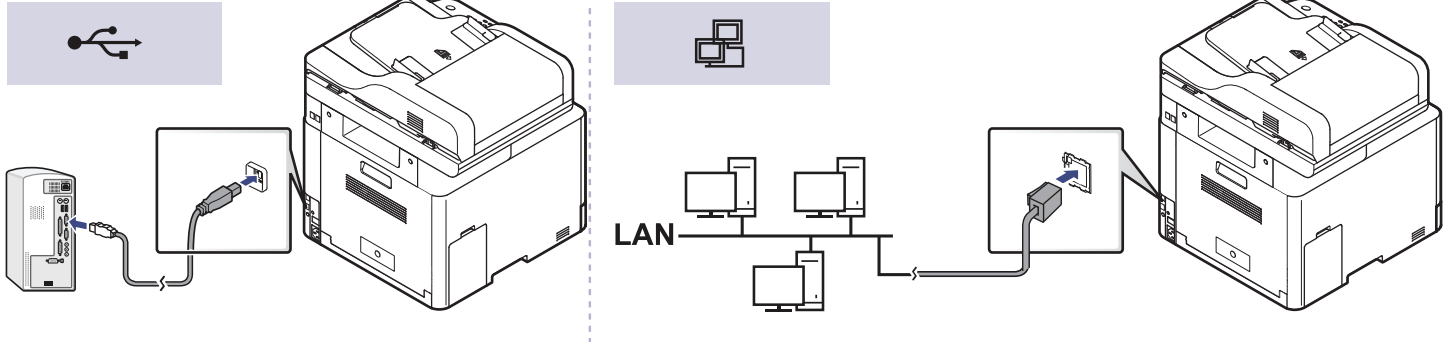
Condition	Suggested solutions
<p>The machine is not receiving power, or the connection cable between the computer and the machine is not connected properly.</p>	<p>1 Connect the machine to the electricity supply first.</p>  <p>2 Check the USB cable or network cable in the machine's rear.</p>  <p>3 Disconnect the USB cable or network cable in the machine's rear and then, reconnect it.</p>

# Printing problems

Condition	Possible cause	Suggested solutions
<b>The machine does not print.</b>	The machine is not receiving power.	Connect the machine to the electricity supply first. If the machine has a  ( <b>Power/Wakeup</b> ) button on the control, press it.
	The machine is not selected as the default machine.	Select your machine as your default machine in Windows.
	Check the machine for the following: <ul style="list-style-type: none"><li>• The cover is not closed. Close the cover.</li><li>• Paper is jammed. Clear the paper jam (see "Clearing paper jams" on page 107).</li><li>• No paper is loaded. Load paper (see "Loading paper in the tray" on page 44).</li><li>• The toner cartridge is not installed. Install the toner cartridge (see "Replacing the toner cartridge" on page 89).</li><li>• Make sure the protect cover and sheets are removed from the toner cartridge (see "Replacing the toner cartridge" on page 89).</li></ul> If a system error occurs, contact your service representative.	
	The connection cable between the computer and the machine is not connected properly.	Disconnect the machine cable and reconnect it (see "Rear view" on page 20).
	The connection cable between the computer and the machine is defective.	If possible, attach the cable to another computer that is working properly and print a job. You can also try using a different machine cable.
	The port setting is incorrect.	Check the Windows printer settings to make sure that the print job is sent to the correct port. If the computer has more than one port, make sure that the machine is attached to the correct one.

# Printing problems

Condition	Possible cause	Suggested solutions
<b>The machine does not print.</b>	The machine may be configured incorrectly.	Check the <b>Printing Preferences</b> to ensure that all of the print settings are correct.
	The printer driver may be incorrectly installed.	Uninstall and reinstall the machine's driver.
	The machine is malfunctioning.	Check the display message on the control panel to see if the machine is indicating a system error. Contact a service representative.
	The document size is so big that the hard disk space of the computer is insufficient to access the print job.	Get more hard disk space and print the document again.
	The output tray is full.	Once the paper is removed from the output tray, the machine resumes printing.
<b>The machine selects print materials from the wrong paper source.</b>	The paper option that was selected in the <b>Printing Preferences</b> may be incorrect.	For many software applications, the paper source selection is found under the <b>Paper</b> tab within the <b>Printing Preferences</b> (see "Opening printing preferences" on page 59). Select the correct paper source. See the printer driver help screen (see "Using help" on page 60).
<b>A print job is extremely slow.</b>	The job may be very complex.	Reduce the complexity of the page or try adjusting the print quality settings.
<b>Half the page is blank.</b>	The page orientation setting may be incorrect.	Change the page orientation in your application (see "Opening printing preferences" on page 59). See the printer driver help screen (see "Using help" on page 60).
	The paper size and the paper size settings do not match.	Ensure that the paper size in the printer driver settings matches the paper in the tray. Or, ensure that the paper size in the printer driver settings matches the paper selection in the software application settings you use (see "Opening printing preferences" on page 59).
<b>The machine prints, but the text is wrong, garbled, or incomplete.</b>	The machine cable is loose or defective.	Disconnect the machine cable and reconnect. Try a print job that you have already printed successfully. If possible, attach the cable and the machine to another computer that you know works and try a print job. Finally, try a new machine cable.



# Printing problems

Condition	Possible cause	Suggested solutions
	The wrong printer driver was selected.	Check the application's printer selection menu to ensure that your machine is selected.
	The software application is malfunctioning.	Try printing a job from another application.
	The operating system is malfunctioning.	Exit Windows and reboot the computer. Turn the machine off and back on again.
<b>Pages print, but they are blank.</b>	The toner cartridge is defective or out of toner.	Redistribute the toner, if necessary. If necessary, replace the toner cartridge. <ul style="list-style-type: none"><li>• See "Redistributing toner" on page 87.</li><li>• See "Replacing the toner cartridge" on page 89.</li></ul>
	The file may have blank pages.	Check the file to ensure that it does not contain blank pages.
	Some parts, such as the controller or the board, may be defective.	Contact a service representative.
<b>The machine does not print PDF files correctly. Some parts of graphics, text, or illustrations are missing.</b>	Incompatibility between the PDF file and the Acrobat products.	Printing the PDF file as an image may enable the file to print. Turn on <b>Print As Image</b> from the Acrobat printing options.   It will take longer to print when you print a PDF file as an image.
<b>The print quality of photos is not good. Images are not clear.</b>	The resolution of the photo is very low.	Reduce the photo size. If you increase the photo size in the software application, the resolution will be reduced.
<b>Before printing, the machine emits vapor near the output tray.</b>	Using damp/wet paper can cause vapor [white smoke] during printing.	This is not a problem, just keep printing. If you are bothered by the smoke [vapor], then replace the paper with fresh paper from an unopened ream.

# Printing problems

Condition	Possible cause	Suggested solutions
<b>The machine does not print custom-sized paper, such as billing paper.</b>	Paper size and paper size setting do not match.	Set the correct paper size in the <b>Custom</b> in <b>Paper</b> tab in <b>Printing Preferences</b> (see "Opening printing preferences" on page 59).
<b>The printed billing paper is curled.</b>	The paper type setting does not match.	Change the printer option and try again. Go to <b>Printing Preferences</b> , click <b>Paper</b> tab, and set type to <b>Thin</b> (see "Opening printing preferences" on page 59).

# Printing quality problems

If the inside of the machine is dirty or paper has been loaded improperly, there might be a reduction in print quality. See the table below to clear the problem.

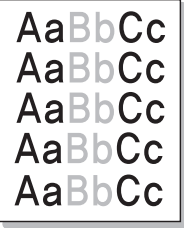
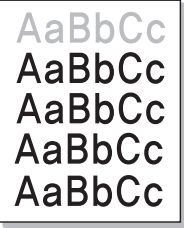
Condition	Suggested solutions
<p data-bbox="49 357 322 389"><b>Light or faded print</b></p> 	<ul data-bbox="504 357 2190 751" style="list-style-type: none"><li>• If a vertical white streak or faded area appears on the page, the toner supply is low. Install a new toner cartridge (see "Replacing the toner cartridge" on page 89).</li><li>• The paper may not meet paper specifications; for example, the paper may be too moist or rough.</li><li>• If the entire page is light, the print resolution setting is too low or the toner save mode is on. Adjust the print resolution and turn the toner save mode off. See the help screen of the printer driver.</li><li>• A combination of faded or smeared defects may indicate that the toner cartridge needs cleaning. Clean the inside of your machine (see "Cleaning the machine" on page 98).</li><li>• The surface of the LSU part inside the machine may be dirty. Clean the inside of your machine (see "Cleaning the machine" on page 98). If these steps do not correct the problem, contact a service representative.</li></ul>
<p data-bbox="49 786 472 903"><b>The top half of the paper is printed lighter than the rest of the paper</b></p> 	<p data-bbox="504 786 1301 818"><b>The toner might not adhere properly to this type of paper.</b></p> <ul data-bbox="504 842 2190 911" style="list-style-type: none"><li>• Change the printer option and try again. Go to <b>Printing Preferences</b>, click the <b>Paper</b> tab, and set the paper type to <b>Recycled</b> (see "Opening printing preferences" on page 59).</li></ul>

# Printing quality problems

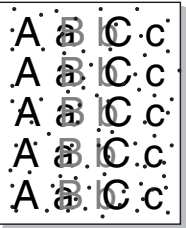
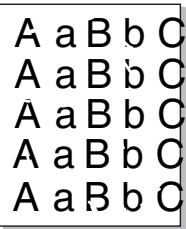
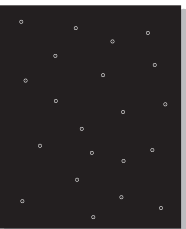
Condition	Suggested solutions
<p><b>Toner specks</b></p> 	<ul style="list-style-type: none"><li>• The paper may not meet specifications; for example, the paper may be too moist or rough.</li><li>• The transfer roller may be dirty. Clean the inside of your machine (see "Cleaning the machine" on page 98).</li><li>• The paper path may need cleaning. Contact a service representative (see "Cleaning the machine" on page 98).</li></ul>
<p><b>Dropouts</b></p> 	<p>If faded areas, generally rounded, occur randomly on the page:</p> <ul style="list-style-type: none"><li>• A single sheet of paper may be defective. Try reprinting the job.</li><li>• The moisture content of the paper is uneven or the paper has moist spots on its surface. Try a different brand of paper.</li><li>• The paper lot is bad. The manufacturing processes can cause some areas to reject toner. Try a different kind or brand of paper.</li><li>• Change the printer option and try again. Go to <b>Printing Preferences</b>, click the <b>Paper</b> tab, and set type to <b>Thick</b> (see "Opening printing preferences" on page 59).</li></ul> <p>If these steps do not correct the problem, contact a service representative.</p>
<p><b>White Spots</b></p> 	<p>If white spots appear on the page:</p> <ul style="list-style-type: none"><li>• The paper is too rough and a lot of dirt from paper falls to the inner components within the machine, so the transfer roller may be dirty. Clean the inside of your machine (see "Cleaning the machine" on page 98).</li><li>• The paper path may need cleaning. Clean the inside of your machine (see "Cleaning the machine" on page 98).</li></ul> <p>If these steps do not correct the problem, contact a service representative.</p>

# Printing quality problems

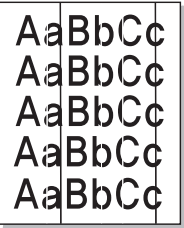
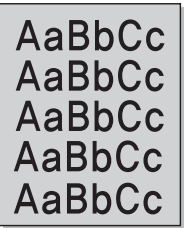
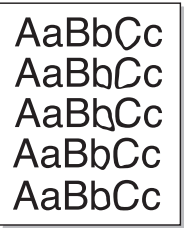
Condition	Suggested solutions
<p><b>Vertical lines</b></p> 	<p>If black vertical streaks appear on the page:</p> <ul style="list-style-type: none"><li>• The surface (drum part) of the toner cartridge inside the machine has probably been scratched. Remove the toner cartridge and install a new one (see "Replacing the toner cartridge" on page 89).</li></ul> <p>If white vertical streaks appear on the page:</p> <ul style="list-style-type: none"><li>• The surface of the LSU part inside the machine may be dirty. Clean the inside of your machine (see "Cleaning the machine" on page 98). If these steps do not correct the problem, contact a service representative.</li></ul>
<p><b>Black or color background</b></p> 	<p>If the amount of background shading becomes unacceptable:</p> <ul style="list-style-type: none"><li>• Change to a lighter weight paper.</li><li>• Check the environmental conditions: very dry conditions or a high level of humidity (higher than 80% RH) can increase the amount of background shading.</li><li>• Remove the old toner cartridge and install a new one (see "Replacing the toner cartridge" on page 89).</li><li>• Thoroughly redistribute the toner (see "Redistributing toner" on page 87).</li></ul>
<p><b>Toner smear</b></p> 	<ul style="list-style-type: none"><li>• Clean the inside of the machine (see "Cleaning the machine" on page 98).</li><li>• Check the paper type and quality.</li><li>• Remove the toner cartridge and install a new one (see "Replacing the toner cartridge" on page 89).</li></ul>

# Printing quality problems

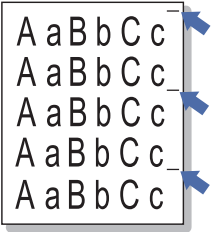
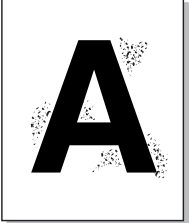
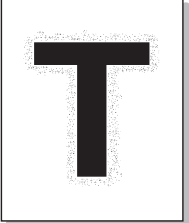
Condition	Suggested solutions
<p data-bbox="49 272 409 304"><b>Vertical repetitive defects</b></p> 	<p data-bbox="504 272 1473 304">If marks repeatedly appear on the printed side of the page at even intervals:</p> <ul data-bbox="504 328 2190 544" style="list-style-type: none"><li data-bbox="504 328 2190 400">• The toner cartridge may be damaged. If you still have the same problem, remove the toner cartridge and, install a new one (see "Replacing the toner cartridge" on page 89).</li><li data-bbox="504 416 2190 488">• Parts of the machine may have toner on them. If the defects occur on the back of the page, the problem will likely correct itself after a few more pages.</li><li data-bbox="504 504 1464 544">• The fusing assembly may be damaged. Contact a service representative.</li></ul>
<p data-bbox="49 612 322 644"><b>Background scatter</b></p> 	<p data-bbox="504 612 1621 644">Background scatter results from bits of toner randomly distributed on the printed page.</p> <ul data-bbox="504 668 2190 1059" style="list-style-type: none"><li data-bbox="504 668 2190 740">• The paper may be too damp. Try printing with a different batch of paper. Do not open packages of paper until necessary so that the paper does not absorb too much moisture.</li><li data-bbox="504 756 2190 876">• If background scatter occurs on an envelope, change the printing layout to avoid printing over areas that have overlapping seams on the reverse side. Printing on seams can cause problems. Or select <b>Thick</b> from the <b>Printing Preferences</b> window (see "Opening printing preferences" on page 59).</li><li data-bbox="504 892 2190 1011">• If background scatter covers the entire surface area of a printed page, adjust the print resolution through your software application or in <b>Printing Preferences</b> (see "Opening printing preferences" on page 59). Ensure the correct paper type is selected. For example: If Thicker Paper is selected, but Plain Paper actually used, an overcharging can occur causing this copy quality problem.</li><li data-bbox="504 1027 1868 1059">• If you are using a new toner cartridge, redistribute the toner first (see "Redistributing toner" on page 87).</li></ul>
<p data-bbox="49 1091 479 1163"><b>Toner particles are around bold characters or pictures</b></p> 	<p data-bbox="504 1091 1249 1123">The toner might not adhere properly to this type of paper.</p> <ul data-bbox="504 1147 2190 1315" style="list-style-type: none"><li data-bbox="504 1147 2190 1219">• Change the printer option and try again. Go to <b>Printing Preferences</b>, click the <b>Paper</b> tab, and set the paper type to <b>Recycled</b> (see "Opening printing preferences" on page 59).</li><li data-bbox="504 1235 2190 1315">• Ensure the correct paper type is selected. For example: If Thicker Paper is selected, but Plain Paper actually used, an overcharging can occur causing this copy quality problem.</li></ul>

# Printing quality problems

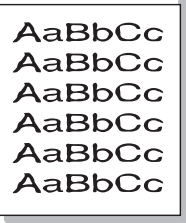
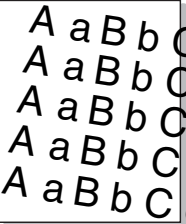
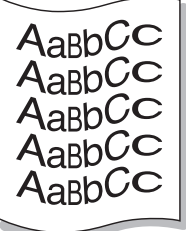

Condition	Suggested solutions
<p data-bbox="49 272 353 304"><b>Misformed characters</b></p> 	<ul data-bbox="504 272 2072 304" style="list-style-type: none"><li>• If characters are improperly formed and producing hollow images, the paper stock may be too slick. Try different paper.</li></ul>
<p data-bbox="49 608 203 639"><b>Page skew</b></p> 	<ul data-bbox="504 608 1518 743" style="list-style-type: none"><li>• Ensure that the paper is loaded properly.</li><li>• Check the paper type and quality.</li><li>• Ensure that the guides are not too tight or too loose against the paper stack.</li></ul>
<p data-bbox="49 951 226 983"><b>Curl or wave</b></p> 	<ul data-bbox="504 951 1729 1086" style="list-style-type: none"><li>• Ensure that the paper is loaded properly.</li><li>• Check the paper type and quality. Both high temperature and humidity can cause paper curl.</li><li>• Turn the stack of paper over in the tray. Also try rotating the paper 180° in the tray.</li></ul>

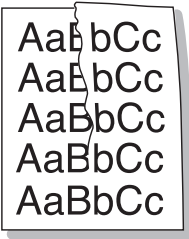
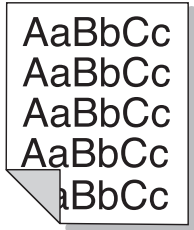
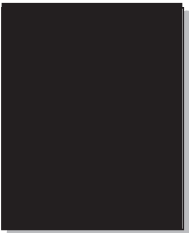
# Printing quality problems

Condition	Suggested solutions
<p data-bbox="49 272 318 300"><b>Wrinkles or creases</b></p> 	<ul data-bbox="504 272 1594 411" style="list-style-type: none"><li>• Ensure that the paper is loaded properly.</li><li>• Check the paper type and quality.</li><li>• Turn the stack of paper over in the tray. Also try rotating the paper 180° in the tray.</li></ul>
<p data-bbox="49 619 412 646"><b>Back of printouts are dirty</b></p> 	<ul data-bbox="504 619 1787 646" style="list-style-type: none"><li>• Check for leaking toner. Clean the inside of the machine (see "Cleaning the machine" on page 98).</li></ul>
<p data-bbox="49 986 405 1013"><b>Solid color or black pages</b></p> 	<ul data-bbox="504 986 2159 1161" style="list-style-type: none"><li>• The toner cartridge may not be installed properly. Remove the cartridge and reinsert it.</li><li>• The toner cartridge may be defective. Remove the toner cartridge and install a new one (see "Replacing the toner cartridge" on page 89).</li><li>• The machine may require repairing. Contact a service representative.</li></ul>

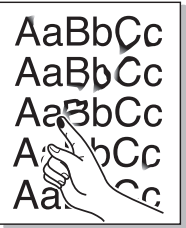

# Printing quality problems

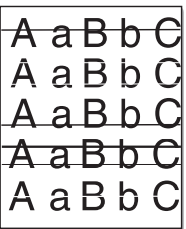
Condition	Suggested solutions
<p><b>Loose toner</b></p> 	<ul style="list-style-type: none"><li>• Clean the inside of the machine (see "Cleaning the machine" on page 98).</li><li>• Check the paper type, thickness, and quality.</li><li>• Remove the toner cartridge and then, install a new one (see "Replacing the toner cartridge" on page 89).</li></ul> <p>If the problem persists, the machine may require repair. Contact a service representative.</p>
<p><b>Character voids</b></p> 	<p>Character voids are white areas within parts of characters that should be solid black:</p> <ul style="list-style-type: none"><li>• You may be printing on the wrong surface of the paper. Remove the paper and turn it around.</li><li>• The paper may not meet paper specifications.</li></ul>
<p><b>Horizontal stripes</b></p> 	<p>If horizontally aligned black streaks or smears appear:</p> <ul style="list-style-type: none"><li>• The toner cartridge may be installed improperly. Remove the cartridge and reinsert it.</li><li>• The toner cartridge may be defective. Remove the toner cartridge and install a new one (see "Replacing the toner cartridge" on page 89).</li></ul> <p>If the problem persists, the machine may require repairing. Contact a service representative.</p>

# Printing quality problems

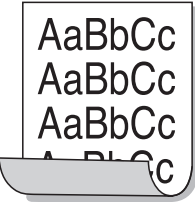
Condition	Suggested solutions
<p><b>Curl</b></p> 	<p>If the printed paper is curled or paper does not feed into the machine:</p> <ul style="list-style-type: none"><li>• Turn the stack of paper over in the tray. Also try rotating the paper 180° in the tray.</li><li>• Change the printer's paper option and try again. Go to <b>Printing Preferences</b>, click the <b>Paper</b> tab, and set type to <b>Thin</b> (see "Opening printing preferences" on page 59).</li></ul>
<ul style="list-style-type: none"><li>• An unknown image repetitively appears on a few sheets</li><li>• Loose toner</li><li>• Light print or contamination occurs</li></ul>	<p>Your machine is probably being used at an altitude of 1,000 m (3,281 ft) or above.</p> <p>The high altitude may affect the print quality, such as loose toner or light imaging. Change the altitude setting for your machine (see "Altitude adjustment" on page 250).</p>

# Copying problems

Condition	Suggested solutions
<b>Copies are too light or too dark.</b>	Adjust the darkness in copy feature to lighten or darken the backgrounds of copies (see "Changing the settings for each copy" on page 64).
<b>Smears, lines, marks, or spots appear on copies.</b>	<ul style="list-style-type: none"><li>• If the defects are on the original, adjust darkness in copy feature to lighten the background of your copies.</li><li>• If there are no defects on the original, clean the scan unit (see "Cleaning the scan unit" on page 102).</li></ul>
<b>Copy image is skewed.</b>	<ul style="list-style-type: none"><li>• Ensure that the original is aligned with the registration guide.</li><li>• The transfer roller may be dirty. Clean the inside of your machine (see "Cleaning the machine" on page 98).</li></ul>
<b>Blank copies print out.</b>	Ensure that the original is face down on the scanner glass or face up in the document feeder. If these steps do not correct the problem, contact a service representative.
<b>Image rubs off the copy easily.</b>	<ul style="list-style-type: none"><li>• Replace the paper in the tray with paper from a new package.</li><li>• In high humidity areas, do not leave paper in the machine for extended periods of time.</li></ul>
<b>Frequent copy paper jams occur.</b>	<ul style="list-style-type: none"><li>• Fan the paper, then turn it over in the tray. Replace the paper in the tray with a fresh supply. Check/adjust the paper guides, if necessary.</li><li>• Ensure that the paper is the proper type and weight (see "Print media specifications" on page 132).</li><li>• Check for copy paper or pieces of copy paper remaining in the machine after a paper jam has been cleared.</li></ul>
<b>Toner cartridge produces fewer copies than expected before running out of toner.</b>	<ul style="list-style-type: none"><li>• Your originals may contain pictures, solids, or heavy lines. For example, your originals may be forms, newsletters, books, or other documents that use more toner.</li><li>• The scanner lid may be left open while copies are being made.</li><li>• Turn the machine off and back on.</li></ul>

# Scanning problems

Condition	Suggested solutions
<b>The scanner does not work.</b>	<ul style="list-style-type: none"><li>• Make sure that you place the original to be scanned face down on the scanner glass, or face up in the document feeder (see "Loading originals" on page 54).</li><li>• There may not be enough available memory to hold the document you want to scan. Try the Prescan function to see if that works. Try lowering the scan resolution rate.</li><li>• Check that the machine printer cable is connected properly.</li><li>• Make sure that the machine printer cable is not defective. Switch the printer cable with a known good cable. If necessary, replace the printer cable.</li><li>• Check that the scanner is configured correctly. Check scan setting in the application you want to use to make certain that the scanner job is being sent to the correct port (for example, USB001).</li></ul>
<b>The unit scans very slowly.</b>	<ul style="list-style-type: none"><li>• Check if the machine is printing received data. If so, scan the document after the received data has been printed.</li><li>• Graphics are scanned more slowly than text.</li><li>• Communication speed slows in scan mode because of the large amount of memory required to analyze and reproduce the scanned image. Set your computer to the ECP printer mode through BIOS setting. It will help to increase the speed. For details about how to set BIOS, refer to your computer user's guide.</li></ul>

# Scanning problems

Condition	Suggested solutions
<p><b>Message appears on your computer screen:</b></p> <ul style="list-style-type: none"><li>• Device can't be set to the H/W mode you want.</li><li>• Port is being used by another program.</li><li>• Port is disabled.</li><li>• Scanner is busy receiving or printing data. When the current job is completed, try again.</li><li>• Invalid handle.</li><li>• Scanning has failed.</li></ul>	<ul style="list-style-type: none"><li>• There may be a copying or printing job in progress. Try your job again when that job is finished.</li><li>• The selected port is currently being used. Restart your computer and try again.</li><li>• The machine printer cable may be improperly connected or the power may be off.</li><li>• The scanner driver is not installed or the operating environment is not set up properly.</li><li>• Ensure that the machine is properly connected and the power is on, then restart your computer.</li><li>• The USB cable may be improperly connected or the power may be off.</li></ul>

# Faxing problems

Condition	Suggested solutions
<b>The machine is not working, there is no display, or the buttons are not working.</b>	<ul style="list-style-type: none"><li>• Unplug the power cord and plug it in again.</li><li>• Ensure that there is power being supplied to the electrical outlet.</li><li>• Ensure that the power is turned on.</li></ul>
<b>No dial tone.</b>	<ul style="list-style-type: none"><li>• Check that the phone line is properly connected (see "Rear view" on page 20).</li><li>• Check that the phone socket on the wall is working by plugging in another phone.</li></ul>
<b>The numbers stored in memory do not dial correctly.</b>	Make sure that the numbers are stored in memory correctly. To check that, print an address book list.
<b>The original does not feed into the machine.</b>	<ul style="list-style-type: none"><li>• Make sure that the paper is not wrinkled and you are inserting it in correctly. Check that the original is the right size, not too thick or thin.</li><li>• Make sure that the document feeder is firmly closed.</li><li>• The document feeder rubber pad may need to be replaced. Contact a service representative (see "Available maintenance parts" on page 84).</li></ul>
<b>Faxes are not received automatically.</b>	<ul style="list-style-type: none"><li>• The receiving mode should be set to fax (see "Changing the receive modes" on page 290).</li><li>• Make sure that there is paper in the tray (see "Print media specifications" on page 132).</li><li>• Check to see if the display shows any error message. If it does, clear the problem.</li></ul>
<b>The machine does not send.</b>	<ul style="list-style-type: none"><li>• Make sure that the original is loaded in the document feeder or on the scanner glass.</li><li>• Check the fax machine you are sending to, to see if it can receive your fax.</li></ul>
<b>The incoming fax has blank spaces or is of poor-quality.</b>	<ul style="list-style-type: none"><li>• The fax machine sending you the fax may be faulty.</li><li>• A noisy phone line can cause line errors.</li><li>• Check your machine by making a copy.</li><li>• A toner cartridge has almost reached its estimated cartridge life. Replace the toner cartridge (see "Replacing the toner cartridge" on page 89).</li></ul>

# Faxing problems

Condition	Suggested solutions
<b>Some of the words on an incoming fax are stretched.</b>	The fax machine sending the fax had a temporary document jam.
<b>There are lines on the originals you sent.</b>	Check your scan unit for marks and clean it (see "Cleaning the scan unit" on page 102).
<b>The machine dials a number, but the connection with the other fax machine fails.</b>	The other fax machine may be turned off, out of paper, or cannot answer incoming calls. Speak with the other machine operator and ask them to solve the problem on their side.
<b>Faxes do not store in memory.</b>	There may not be enough memory space to store the fax. If the display indicating the memory status shows, delete any faxes you no longer need from the memory, and then try to store the fax again. Call for service.
<b>Blank areas appear at the bottom of each page or on other pages, with a small strip of text at the top.</b>	You may have chosen the wrong paper settings in the user option setting. Check the paper size and type again.

# Operating system problems

## Common Windows problems

Condition	Suggested solutions
<b>“File in Use” message appears during installation.</b>	Exit all software applications. Remove all software from the startup group, then restart Windows. Reinstall the printer driver.
<b>“General Protection Fault”, “Exception OE”, “Spool 32”, or “Illegal Operation” messages appear.</b>	Close all other applications, reboot Windows and try printing again.
<b>“Fail To Print”, “A printer timeout error occurred” message appear.</b>	These messages may appear during printing. Just keep waiting until the machine finishes printing. If the message appears in ready mode or after printing has completed, check the connection and/or whether an error has occurred.
<b>Samsung Printer Experience is not shown when you click more settings.</b>	<b>Samsung Printer Experience</b> is not installed. Download the app from the Windows <b>Store</b> and install it.
<b>Machine information is not displayed when you click the device in the Devices and Printers.</b>	Check the <b>Printer properties</b> . Click the <b>Ports</b> tab. ( <b>Control Panel</b> > <b>Devices and Printers</b> > Right-click on your printer icon and select <b>Printer properties</b> ) If the port is set to File or LPT, uncheck them and select TCP/IP, USB, or WSD.



Refer to the Microsoft Windows User's Guide that came with your computer for further information on Windows error messages.



# Operating system problems

## Common Mac problems

Condition	Suggested solutions
<b>The machine does not print PDF files correctly. Some parts of graphics, text, or illustrations are missing.</b>	<p>Printing the PDF file as an image may enable the file to print. Turn on <b>Print As Image</b> from the Acrobat printing options.</p> <p> It will take longer to print when you print a PDF file as an image.</p>
<b>Some letters are not displayed normally during cover page printing.</b>	<p>Mac OS cannot create the font while printing the cover page. The English alphabet and numbers are displayed normally on the cover page.</p>
<b>When printing a document in Mac with Acrobat Reader 6.0 or higher, colors print incorrectly.</b>	<p>Make sure that the resolution setting in your machine driver matches the one in Acrobat Reader.</p>



Refer to the Mac User's Guide that came with your computer for further information on Mac error messages.

# Operating system problems

## Common Linux problems

Condition	Suggested solutions
<b>There is no xsane nor simple-scan application on my Linux machine.</b>	For some Linux distributions, there might be no default scan application. To use scan features, install one of scan applications using download center supplied by the OS(ex. Ubuntu Software Center for Ubuntu, Install/Remove Software for openSUSE, Software for Fedora).
<b>Scanner can not be found via network.</b>	For some Linux distributions, strong firewall is enabled and it may block our installer from opening the necessary port for searching network devices. In such a case, open the snmp port - 22161 manually or disable the firewall temporarily while using the device.
<b>When printing more than one copy, the second copy does not print.</b>	The problem occurs on Ubuntu 12.04 due to the problem in standard CUPS filter 'pdftops'. Update 'cups-filters' package to version 1.0.18 to fix the problem ('pdftops' is a part of 'cups-filters' package).
<b>Unchecking the collate option in the Print Dialog does not work.</b>	For some distributions, GNOME Print Dialog has an issue handling the collate option. As workaround, set the default value of collate option to <b>False</b> using the system's printing utility(execute "system-config-printer" in the Terminal program).
<b>Printing always works with duplex.</b>	This duplex issue was in Ubuntu 9.10 CUPS package. Update CUPS version to 1.4.1-5ubuntu2.2.
<b>Printer is not added through system's printing utility.</b>	The problem occurs on Debian 7 due to the defect in 'system-config-printer' package of the Debian 7 ( <a href="http://bugs.debian.org/cgi-bin/bugreport.cgi?bug=662813">http://bugs.debian.org/cgi-bin/bugreport.cgi?bug=662813</a> in Debian bug tracking system). Please use another way to add printer (CUPS WebUI for example)
<b>Paper size and orientation are disabled in the Print Dialog when opening text files.</b>	The problem occurs on Fedora 19 and it's related to 'leafpad' text editor on Fedora 19. Please use other text editors like 'gedit'.



Refer to the Linux User's Guide that came with your computer for further information on Linux error messages.

# Operating system problems

## Common PostScript problems

The following situations are PS language specific and may occur when several printer languages are used.

Problem	Possible cause	Solution
<b>The PostScript file cannot be printed</b>	The PostScript driver may not be installed correctly.	<ul style="list-style-type: none"><li>• Install the PostScript driver (see "Software Installation" on page 157).</li><li>• Print a configuration page and verify that the PS version is available for printing.</li><li>• If the problem persists, contact a service representative.</li></ul>
<b>Limit Check Error report prints</b>	The print job was too complex.	You might need to reduce the complexity of the page or install more memory.
<b>A PostScript error page prints</b>	The print job may not be PostScript.	Make sure that the print job is a PostScript job. Check to see whether the software application expected a setup or PostScript header file to be sent to the machine.
<b>The optional tray is not selected in the driver</b>	The printer driver has not been configured to recognize the optional tray.	Open the PostScript driver properties, select the <b>Device Options</b> tab, and set the tray option (see "Setting Device Options" on page 94).
<b>When printing a document in Mac with Acrobat Reader 6.0 or higher, colors print incorrectly</b>	The resolution setting in the printer driver may not be matched with the one in Acrobat Reader.	Make sure that the resolution setting in your printer driver matches the one in Acrobat Reader.

# Contact SAMSUNG worldwide

If you have any comments or questions regarding Samsung products, contact the Samsung customer care center.

Country/Region	Customer Care Center	WebSite
<b>ALGERIA</b>	3004 (Toll Free)	www.samsung.com/n_africa/support
<b>ANGOLA</b>	917 267 864	www.samsung.com/support
<b>ARGENTINE</b>	0800-555-SAM(7267)	www.samsung.com/ar
<b>ARMENIA</b>	0-800-05-555	www.samsung.com/support
<b>AUSTRALIA</b>	1300 362 603	www.samsung.com/au/support
<b>AUSTRIA</b>	0800-SAMSUNG (0800-7267864) [Only for Premium HA] 0800-366661 [Only for Dealers] 0810-112233	www.samsung.com/at/support
<b>AZERBAIJAN</b>	0-88-555-55-55	www.samsung.com/support
<b>BAHRAIN</b>	8000-GSAM (8000-4726)	www.samsung.com/ae/support (English) www.samsung.com/ae_ar/support (Arabic)
<b>BANGLADESH</b>	0961-2300300 0800-0300300 (Toll free)	www.samsung.com/in/support

Country/Region	Customer Care Center	WebSite
<b>BELARUS</b>	810-800-500-55-500	www.samsung.com/support
<b>BELGIUM</b>	02-201-24-18	www.samsung.com/be/support (Dutch) www.samsung.com/be_fr/support (French)
<b>BOLIVIA</b>	800-10-7260	www.samsung.com/cl/support
<b>BOSNIA</b>	055 233 999	www.samsung.com/support
<b>BOTSWANA</b>	8007260000	www.samsung.com/support
<b>BRAZIL</b>	0800-124-421 (Demais cidades e regiões) 4004-0000 (Capitais e grandes centros)	www.samsung.com/br/support
<b>BULGARIA</b>	0800 111 31 , Безплатна телефонна линия	www.samsung.com/bg/support
<b>BURUNDI</b>	200	www.samsung.com/support
<b>CAMEROON</b>	7095- 0077	www.samsung.com/africa_fr/support
<b>CANADA</b>	1-800-SAMSUNG (726-7864)	www.samsung.com/ca/support(English) www.samsung.com/ca_fr/support (French)

# Contact SAMSUNG worldwide

Country/Region	Customer Care Center	WebSite
<b>CHILE</b>	800-SAMSUNG (726-7864) [HHP] 02-24828200	www.samsung.com/ cl/support
<b>CHINA</b>	400-810-5858	www.samsung.com/ cn/support
<b>COLOMBIA</b>	Bogotá en el 600 12 72 Sin costo en todo el país 01 8000 112 112 Y desde tu celular #726	www.samsung.com/ co
<b>COSTA RICA</b>	00-800-1-SAMSUNG (726-7864)	www.samsung.com/ latin/support (Spanish) www.samsung.com/ latin_en/support (English)
<b>CROATIA</b>	072 726 786	www.samsung.com/ hr/support
<b>Cote D' Ivoire</b>	8000 0077	www.samsung.com/ africa_fr/support
<b>CYPRUS</b>	8009 4000 only from landline, toll free	www.samsung.com/ gr/support
<b>CZECH</b>	800-SAMSUNG (800-726786)	www.samsung.com/ cz/support
<b>DENMARK</b>	70 70 19 70	www.samsung.com/ dk/support

Country/Region	Customer Care Center	WebSite
<b>DOMINICAN REPUBLIC</b>	1-800-751-2676	www.samsung.com/ latin/support (Spanish) www.samsung.com/ latin_en/support (English)
<b>DRC</b>	4999999	www.samsung.com/ support
<b>ECUADOR</b>	1-800-SAMSUNG (72-6786)	www.samsung.com/ latin/support (Spanish) www.samsung.com/ latin_en/ support(English)
<b>EGYPT</b>	08000-7267864 16580	www.samsung.com/ eg/support
<b>EIRE</b>	0818 717100	www.samsung.com/ ie/support
<b>EL SALVADOR</b>	8000-SAMSUNG (726-7864)	www.samsung.com/ latin/support (Spanish) www.samsung.com/ latin_en/support (English)
<b>ESTONIA</b>	800-7267	www.samsung.com/ ee/support

# Contact SAMSUNG worldwide

Country/Region	Customer Care Center	WebSite
<b>FINLAND</b>	030-6227 515	<a href="http://www.samsung.com/fi/support">www.samsung.com/fi/support</a>
<b>FRANCE</b>	01 48 63 00 00	<a href="http://www.samsung.com/fr/support">www.samsung.com/fr/support</a>
<b>GERMANY</b>	0180 6 SAMSUNG bzw. 0180 6 7267864* (*0,20 €/Anruf aus dem dt. Festnetz, aus dem Mobilfunk max. 0,60 €/Anruf) [HHP] 0180 6 M SAMSUNG bzw. 0180 6 67267864* (*0,20 €/Anruf aus dem dt. Festnetz, aus dem Mobilfunk max. 0,60 €/Anruf)	<a href="http://www.samsung.com/de/support">www.samsung.com/de/support</a>
<b>GEORGIA</b>	0-800-555-555	<a href="http://www.samsung.com/support">www.samsung.com/support</a>
<b>GHANA</b>	0800-10077 0302-200077	<a href="http://www.samsung.com/africa_en/support">www.samsung.com/africa_en/support</a>
<b>GREECE</b>	80111-SAMSUNG (80111 726 7864) only from land line (+30) 210 6897691 from mobile and land line	<a href="http://www.samsung.com/gr/support">www.samsung.com/gr/support</a>

Country/Region	Customer Care Center	WebSite
<b>GUATEMALA</b>	1-800-299-0033	<a href="http://www.samsung.com/latin/support">www.samsung.com/latin/support</a> (Spanish) <a href="http://www.samsung.com/latin_en/support">www.samsung.com/latin_en/support</a> (English)
<b>HONDURAS</b>	800-2791-9111	<a href="http://www.samsung.com/latin/support">www.samsung.com/latin/support</a> (Spanish) <a href="http://www.samsung.com/latin_en/support">www.samsung.com/latin_en/support</a> (English)
<b>HONG KONG</b>	3698 4698	<a href="http://www.samsung.com/hk/support">www.samsung.com/hk/support</a> (Chinese) <a href="http://www.samsung.com/hk_en/support">www.samsung.com/hk_en/support</a> (English)
<b>HUNGARY</b>	0680SAMSUNG (0680-726-786) 0680PREMIUM (0680-773-648)	<a href="http://www.samsung.com/hu/support">www.samsung.com/hu/support</a>
<b>INDIA</b>	1800 3000 8282 - Toll Free 1800 266 8282 - Toll Free	<a href="http://www.samsung.com/in/support">www.samsung.com/in/support</a>
<b>INDONESIA</b>	021-56997777 08001128888	<a href="http://www.samsung.com/id/support">www.samsung.com/id/support</a>
<b>IRAN</b>	021-8255 [CE] 021-42132 [HHP]	<a href="http://www.samsung.com/iran/support">www.samsung.com/iran/support</a>

# Contact SAMSUNG worldwide

Country/Region	Customer Care Center	WebSite
<b>ITALIA</b>	800-SAMSUNG (800.7267864)	www.samsung.com/ it/support
<b>JAMAICA</b>	1-800-SAMSUNG (726-7864)	www.samsung.com/ latin_en/support (English)
<b>JAPAN</b>	0120-363-905	www.samsung.com/ jp/support
<b>JORDAN</b>	0800-22273 06 5777444	www.samsung.com/ Levant
<b>KAZAKHSTAN</b>	8-10-800-500-55-500 (GSM: 7799, VIP care 7700)	www.samsung.com/ kz_ru/support
<b>KENYA</b>	0800 545 545	www.samsung.com/ support
<b>KUWAIT</b>	183-CALL (183-2255)	www.samsung.com/ ae/support (English) www.samsung.com/ ae_ar/support (Arabic)
<b>KYRGYZSTAN</b>	00-800-500-55-500 (GSM: 9977)	www.samsung.com/ support
<b>LATVIA</b>	8000-7267	www.samsung.com/ lv/support
<b>LEBANON</b>	961 1484 999	www.samsung.com/ Levant
<b>LITHUANIA</b>	8-800-77777	www.samsung.com/ lt/support

Country/Region	Customer Care Center	WebSite
<b>LUXEMBURG</b>	261 03 710	www.samsung.com/ be_fr/support
<b>MACAU</b>	0800 333	www.samsung.com/ support
<b>MACEDONIA</b>	023 207 777	
<b>MALAYSIA</b>	1800-88-9999 603-77137477 (Overseas contact)	www.samsung.com/ my/support
<b>MAURITIUS</b>	800 2550	www.samsung.com/ support
<b>MEXICO</b>	01-800-SAMSUNG (726-7864)	www.samsung.com/ mx/support
<b>MOLDOVA</b>	0-800-614-40	www.samsung.com/ support
<b>MONGOLIA</b>	+7-495-363-17-00	www.samsung.com/ support
<b>MONTENEGRO</b>	020 405 888	www.samsung.com/ support
<b>MOROCCO</b>	080 100 22 55	www.samsung.com/ n_africa/support
<b>MOZAMBIQUE</b>	847267864 / 827267864	www.samsung.com/ support
<b>MYANMAR</b>	+95-01-2399-888	www.samsung.com/ support
<b>NAMIBIA</b>	08 197 267 864	www.samsung.com/ support

# Contact SAMSUNG worldwide

Country/Region	Customer Care Center	WebSite
<b>NIGERIA</b>	0800-726-7864	www.samsung.com/ africa_en/support
<b>NETHERLANDS</b>	0900-SAMSUNG (0900-7267864) (€ 0,10/Min)	www.samsung.com/ nl/support
<b>NEW ZEALAND</b>	0800 726 786	www.samsung.com/ nz/support
<b>NICARAGUA</b>	001-800-5077267	www.samsung.com/ latin/support(Spanish)  www.samsung.com/ latin_en/support (English)
<b>NORWAY</b>	815 56480	www.samsung.com/ no/support
<b>OMAN</b>	800-SAMSUNG (800 - 726 7864)	www.samsung.com/ ae/support (English)  www.samsung.com/ ae_ar/support (Arabic)
<b>PAKISTAN</b>	0800-Samsung (72678)	www.samsung.com/ pk/support
<b>PANAMA</b>	800-0101	www.samsung.com/ latin/support (Spanish)  www.samsung.com/ latin_en/support (English)
<b>PARAGUAY</b>	0800-11-SAMS(7267)	www.samsung.com/ar

Country/Region	Customer Care Center	WebSite
<b>PERU</b>	0800-777-08	www.samsung.com/ pe/support
<b>PHILIPPINES</b>	1-800-10-726-7864 [ PLDT Toll Free ]  1-800-8-726-7864 [ Globe Landline and Mobile ]  02- 422-2111 [ Standard Landline ]	www.samsung.com/ ph/support
<b>POLAND</b>	801-172-678* lub +48 22 607-93- 33*  Dedykowana infolinia do obsługi zapytań dotyczących telefonów komórkowych: 801-672-678* lub +48 22 607-93-33*  * (koszt połączenia według taryfy operatora)	www.samsung.com/ pl/support
<b>PORTUGAL</b>	808 20 7267	www.samsung.com/ pt/support
<b>PUERTO RICO</b>	1-800-682-3180	www.samsung.com/ latin/support (Spanish)  www.samsung.com/ latin_en/support (English)



# Contact SAMSUNG worldwide

Country/Region	Customer Care Center	WebSite
<b>QATAR</b>	800-CALL (800-2255)	www.samsung.com/ ae/support (English) www.samsung.com/ ae_ar/support (Arabic)
<b>REUNION</b>	0262 50 88 80	www.samsung.com/ support
<b>RWANDA</b>	9999	www.samsung.com/ support
<b>ROMANIA</b>	*8000 (apel in retea) 08008-726-78-64 (08008- SAMSUNG) Apel GRATUIT	www.samsung.com/ ro/support
<b>RUSSIA</b>	8-800-555-55-55 (VIP care 8-800- 555-55-88)	www.samsung.com/ ru/support
<b>SAUDI ARABIA</b>	800 247 3457 (800 24/7 HELP)	www.samsung.com/ sa/home www.samsung.com/ sa_en
<b>SENEGAL</b>	800-00-0077	www.samsung.com/ africa_fr/support
<b>SERBIA</b>	011 321 6899	www.samsung.com/ rs/support
<b>SINGAPORE</b>	1800-SAMSUNG (726-7864)	www.samsung.com/ sg/support
<b>SLOVENIA</b>	080 697 267 (brezplačna številka)	www.samsung.com/si

Country/Region	Customer Care Center	WebSite
<b>SLOVAKIA</b>	0800 - SAMSUNG (0800-726 786)	www.samsung.com/ sk/support
<b>SOUTH AFRICA</b>	0860 SAMSUNG (726 7864)	www.samsung.com/ support
<b>SPAIN</b>	0034902172678 [HHP] 0034902167267	www.samsung.com/ es/support
<b>SRI LANKA</b>	0117540540 0115900000	www.samsung.com/ support
<b>SUDAN</b>	1969	www.samsung.com/ support
<b>SWEDEN</b>	0771 726 7864 (0771-SAMSUNG)	www.samsung.com/ se/support
<b>SWITZERLAND</b>	0800 726 78 64 (0800-SAMSUNG)	www.samsung.com/ ch/support (German) www.samsung.com/ ch_fr/support (French)
<b>SYRIA</b>	18252273	www.samsung.com/ Levant
<b>TAJIKISTAN</b>	8-10-800-500-55-500	www.samsung.com/ support
<b>TAIWAN</b>	0800-329999	www.samsung.com/ tw/support
<b>TANZANIA</b>	0800 755 755 0685 889 900	www.samsung.com/ support

# Contact SAMSUNG worldwide

Country/Region	Customer Care Center	WebSite
<b>THAILAND</b>	0-2689-3232, 1800-29-3232	www.samsung.com/ th/support
<b>TRINIDAD &amp; TOBAGO</b>	1-800-SAMSUNG (726-7864)	www.samsung.com/ latin/support (Spanish)  www.samsung.com/ latin_en/support (English)
<b>TURKEY</b>	444 77 11	www.samsung.com/ tr/support
<b>TUNISIA</b>	80-1000-12	www.samsung.com/ n_africa/support
<b>U.A.E</b>	800-SAMSUNG (800 -726 7864)	www.samsung.com/ ae/support (English)  www.samsung.com/ ae_ar/support (Arabic)
<b>UK</b>	0330 SAMSUNG (7267864)	www.samsung.com/ uk/support
<b>U.S.A -Consumer Electronics</b>	1-800-SAMSUNG (726-7864)	www.samsung.com/ us/support
<b>U.S.A -(Mobile Phones)</b>	1-800-SAMSUNG (726-7864)	www.samsung.com/ us/support
<b>UGANDA</b>	0800 300 300	www.samsung.com/ support

Country/Region	Customer Care Center	WebSite
<b>UKRAINE</b>	0-800-502-000	www.samsung.com/ ua/support (Ukrainian)  www.samsung.com/ ua_ru/support (Russian)
<b>URUGUAY</b>	0800-SAMS(7267)	www.samsung.com/ar
<b>UZBEKISTAN</b>	00-800-500-55-500 (GSM: 7799)	www.samsung.com/ support
<b>VENEZUELA</b>	0-800-SAMSUNG (726-7864)	www.samsung.com/ ve/support
<b>VIETNAM</b>	1800 588 889	www.samsung.com/ vn/support
<b>ZAMBIA</b>	0211 350370	www.samsung.com/ support



The following glossary helps you get familiar with the product by understanding the terminologies commonly used with printing as well as mentioned in this user's guide.

## 802.11

---

802.11 is a set of standards for wireless local area network (WLAN) communication, developed by the IEEE LAN/MAN Standards Committee (IEEE 802).

## 802.11b/g/n

---

802.11b/g/n can share same hardware and use the 2.4 GHz band. 802.11b supports bandwidth up to 11 Mbps, 802.11n supports bandwidth up to 150 Mbps. 802.11b/g/n devices may occasionally suffer interference from microwave ovens, cordless telephones, and Bluetooth devices.

## Access point

---

Access Point or Wireless Access Point (AP or WAP) is a device that connects wireless communication devices together on wireless local area networks (WLAN), and acts as a central transmitter and receiver of WLAN radio signals.

## ADF

---

An Automatic Document Feeder (ADF) is a scanning unit that will automatically feed an original sheet of paper so that the machine can scan some amount of the paper at once.

## AppleTalk

---

AppleTalk is a proprietary suite of protocols developed by Apple, Inc for computer networking. It was included in the original Mac (1984) and is now deprecated by Apple in favor of TCP/IP networking.

## BIT Depth

---

A computer graphics term describing the number of bits used to represent the color of a single pixel in a bitmapped image. Higher color depth gives a broader range of distinct colors. As the number of bits increases, the number of possible colors becomes impractically large for a color map. 1-bit color is commonly called as monochrome or black and white.

## BMP

---

A bitmapped graphics format used internally by the Microsoft Windows graphics subsystem (GDI), and used commonly as a simple graphics file format on that platform.

## BOOTP

---

Bootstrap Protocol. A network protocol used by a network client to obtain its IP address automatically. This is usually done in the bootstrap process of computers or operating systems running on them. The BOOTP servers assign the IP address from a pool of addresses to each client. BOOTP enables 'diskless workstation' computers to obtain an IP address prior to loading any advanced operating system.

## CCD

---

Charge Coupled Device (CCD) is a hardware which enables the scan job. CCD Locking mechanism is also used to hold the CCD module to prevent any damage when you move the machine.

## Collation

---

Collation is a process of printing a multiple-copy job in sets. When collation is selected, the device prints an entire set before printing additional copies.

## Control Panel

---

A control panel is a flat, typically vertical, area where control or monitoring instruments are displayed. They are typically found in front of the machine.

## Coverage

---

It is the printing term used for a toner usage measurement on printing. For example, 5% coverage means that an A4 sided paper has about 5% image or text on it. So, if the paper or original has complicated images or lots of text on it, the coverage will be higher and at the same time, a toner usage will be as much as the coverage.

## CSV

---

Comma Separated Values (CSV). A type of file format, CSV is used to exchange data between disparate applications. The file format, as it is used in Microsoft Excel, has become a de facto standard throughout the industry, even among non-Microsoft platforms.

## RADF

---

A Reverse Automatic Document Feeder (RADF) is a scanning unit that will automatically feed and turn over an original sheet of paper so that the machine can scan on both sides of the paper.

## Default

---

The value or setting that is in effect when taking a printer out of its box state, reset, or initialized.

## DHCP

---

A Dynamic Host Configuration Protocol (DHCP) is a client-server networking protocol. A DHCP server provides configuration parameters specific to the DHCP client host requesting, generally, information required by the client host to participate on an IP network. DHCP also provides a mechanism for allocation of IP addresses to client hosts.

## DIMM

---

Dual Inline Memory Module (DIMM), a small circuit board that holds memory. DIMM stores all the data within the machine like printing data, received fax data.

## DLNA

---

The Digital Living Network Alliance (DLNA) is a standard that allows devices on a home network to share information with each other across the network.

## DNS

---

The Domain Name Server (DNS) is a system that stores information associated with domain names in a distributed database on networks, such as the Internet.

## Dot Matrix Printer

---

A dot matrix printer refers to a type of computer printer with a print head that runs back and forth on the page and prints by impact, striking an ink-soaked cloth ribbon against the paper, much like a typewriter.

## DPI

---

Dots Per Inch (DPI) is a measurement of resolution that is used for scanning and printing. Generally, higher DPI results in a higher resolution, more visible detail in the image, and a larger file size.

## DRPD

---

Distinctive Ring Pattern Detection. Distinctive Ring is a telephone company service which enables a user to use a single telephone line to answer several different telephone numbers.

## Duplex

---

A mechanism that will automatically turn over a sheet of paper so that the machine can print (or scan) on both sides of the paper. A printer equipped with a Duplex Unit can print on both sides of paper during one print cycle.

## Duty Cycle

---

Duty cycle is the page quantity which does not affect printer performance for a month. Generally the printer has the lifespan limitation such as pages per year. The lifespan means the average capacity of print-outs, usually within the warranty period. For example, if the duty cycle is 48,000 pages per month assuming 20 working days, a printer limits 2,400 pages a day.

## ECM

---

Error Correction Mode (ECM) is an optional transmission mode built into Class 1 fax machines or fax modems. It automatically detects and corrects errors in the fax transmission process that are sometimes caused by telephone line noise.

## Emulation

---

Emulation is a technique of one machine obtaining the same results as another.

An emulator duplicates the functions of one system with a different system, so that the second system behaves like the first system. Emulation focuses on exact reproduction of external behavior, which is in contrast to simulation, which concerns an abstract model of the system being simulated, often considering its internal state.

## Ethernet

---

Ethernet is a frame-based computer networking technology for local area networks (LANs). It defines wiring and signaling for the physical layer, and frame formats and protocols for the media access control (MAC)/data link layer of the OSI model. Ethernet is mostly standardized as IEEE 802.3. It has become the most widespread LAN technology in use during the 1990s to the present.

## EtherTalk

---

A suite of protocols developed by Apple Computer for computer networking. It was included in the original Mac (1984) and is now deprecated by Apple in favor of TCP/IP networking.

## FDI

---

Foreign Device Interface (FDI) is a card installed inside the machine to allow a third party device such as a coin operated device or a card reader. Those devices allow the pay-for-print service on your machine.

## FTP

---

A File Transfer Protocol (FTP) is a commonly used protocol for exchanging files over any network that supports the TCP/IP protocol (such as the Internet or an intranet).

## Fuser Unit

---

The part of a laser printer that fuses the toner onto the print media. It consists of a heat roller and a pressure roller. After toner is transferred onto the paper, the fuser unit applies heat and pressure to ensure that the toner stays on the paper permanently, which is why paper is warm when it comes out of a laser printer.

## Gateway

---

A connection between computer networks, or between a computer network and a telephone line. It is very popular, as it is a computer or a network that allows access to another computer or network.

## Grayscale

---

A shades of gray that represents light and dark portions of an image when color images are converted to grayscale; colors are represented by various shades of gray.

## Halftone

---

An image type that simulates grayscale by varying the number of dots. Highly colored areas consist of a large number of dots, while lighter areas consist of a smaller number of dots.

## Mass storage device

---

Mass storage device, commonly referred to as a hard drive or hard disk, is a non-volatile storage device which stores digitally-encoded data on rapidly rotating platters with magnetic surfaces.

## IEEE

---

The Institute of Electrical and Electronics Engineers (IEEE) is an international non-profit, professional organization for the advancement of technology related to electricity.

## IEEE 1284

---

The 1284 parallel port standard was developed by the Institute of Electrical and Electronics Engineers (IEEE). The term "1284-B" refers to a specific connector type on the end of the parallel cable that attaches to the peripheral (for example, a printer).

## Intranet

---

A private network that uses Internet Protocols, network connectivity, and possibly the public telecommunication system to securely share part of an organization's information or operations with its employees. Sometimes the term refers only to the most visible service, the internal website.

## IP address

---

An Internet Protocol (IP) address is a unique number that devices use in order to identify and communicate with each other on a network utilizing the Internet Protocol standard.

## IPM

---

The Images Per Minute (IPM) is a way of measuring the speed of a printer. An IPM rate indicates the number of single-sided sheets a printer can complete within one minute.

## IPP

---

The Internet Printing Protocol (IPP) defines a standard protocol for printing as well as managing print jobs, media size, resolution, and so forth. IPP can be used locally or over the Internet to hundreds of printers, and also supports access control, authentication, and encryption, making it a much more capable and secure printing solution than older ones.

## IPX/SPX

---

IPX/SPX stands for Internet Packet Exchange/Sequenced Packet Exchange. It is a networking protocol used by the Novell NetWare operating systems. IPX and SPX both provide connection services similar to TCP/IP, with the IPX protocol having similarities to IP, and SPX having similarities to TCP. IPX/SPX was primarily designed for local area networks (LANs), and is a very efficient protocol for this purpose (typically its performance exceeds that of TCP/IP on a LAN).

## ISO

---

The International Organization for Standardization (ISO) is an international standard-setting body composed of representatives from national standards bodies. It produces world-wide industrial and commercial standards.

## ITU-T

---

The International Telecommunication Union is an international organization established to standardize and regulate international radio and telecommunications. Its main tasks include standardization, allocation of the radio spectrum, and organizing interconnection arrangements between different countries to allow international phone calls. A -T out of ITU-T indicates telecommunication.

## ITU-T No. 1 chart

---

Standardized test chart published by ITU-T for document facsimile transmissions.

## JBIG

---

Joint Bi-level Image Experts Group (JBIG) is an image compression standard with no loss of accuracy or quality, which was designed for compression of binary images, particularly for faxes, but can also be used on other images.

## JPEG

---

Joint Photographic Experts Group (JPEG) is a most commonly used standard method of lossy compression for photographic images. It is the format used for storing and transmitting photographs on the World Wide Web.



## LDAP

---

The Lightweight Directory Access Protocol (LDAP) is a networking protocol for querying and modifying directory services running over TCP/IP.

## LED

---

A Light-Emitting Diode (LED) is a semiconductor device that indicates the status of a machine.

## MAC address

---

Media Access Control (MAC) address is a unique identifier associated with a network adapter. MAC address is a unique 48-bit identifier usually written as 12 hexadecimal characters grouped in pairs (e. g., 00-00-0c-34-11-4e). This address is usually hard-coded into a Network Interface Card (NIC) by its manufacturer, and used as an aid for routers trying to locate machines on large networks.

## MFP

---

Multi Function Peripheral (MFP) is an office machine that includes the following functionality in one physical body, so as to have a printer, a copier, a fax, a scanner and etc.

## MH

---

Modified Huffman (MH) is a compression method for decreasing the amount of data that needs to be transmitted between the fax machines to transfer the image recommended by ITU-T T.4. MH is a codebook-based run-length encoding scheme optimized to efficiently compress white space. As most faxes consist mostly of white space, this minimizes the transmission time of most faxes.

## MMR

---

Modified Modified READ (MMR) is a compression method recommended by ITU-T T.6.

## Modem

---

A device that modulates a carrier signal to encode digital information, and also demodulates such a carrier signal to decode transmitted information.

## MR

---

Modified Read (MR) is a compression method recommended by ITU-T T.4. MR encodes the first scanned line using MH. The next line is compared to the first, the differences determined, and then the differences are encoded and transmitted.

# Glossary

## NetWare

---

A network operating system developed by Novell, Inc. It initially used cooperative multitasking to run various services on a PC, and the network protocols were based on the archetypal Xerox XNS stack. Today NetWare supports TCP/IP as well as IPX/SPX.

## OPC

---

Organic Photo Conductor (OPC) is a mechanism that makes a virtual image for print using a laser beam emitted from a laser printer, and it is usually green or rust colored and has a cylinder shape.

An imaging unit containing a drum slowly wears the drum surface by its usage in the printer, and it should be replaced appropriately since it gets worn from contact with the cartridge development brush, cleaning mechanism, and paper.

## Originals

---

The first example of something, such as a document, photograph or text, etc, which is copied, reproduced or translated to produce others, but which is not itself copied or derived from something else.

## OSI

---

Open Systems Interconnection (OSI) is a model developed by the International Organization for Standardization (ISO) for communications. OSI offers a standard, modular approach to network design that divides the required set of complex functions into manageable, self-contained, functional layers. The layers are, from top to bottom, Application, Presentation, Session, Transport, Network, Data Link and Physical.

## PABX

---

A private automatic branch exchange (PABX) is an automatic telephone switching system within a private enterprise.

## PCL

---

Printer Command Language (PCL) is a Page Description Language (PDL) developed by HP as a printer protocol and has become an industry standard. Originally developed for early inkjet printers, PCL has been released in varying levels for thermal, dot matrix printer, and laser printers.

## PDF

---

Portable Document Format (PDF) is a proprietary file format developed by Adobe Systems for representing two dimensional documents in a device independent and resolution independent format.

## PostScript

---

PostScript (PS) is a page description language and programming language used primarily in the electronic and desktop publishing areas. - that is run in an interpreter to generate an image.

## Printer Driver

---

A program used to send commands and transfer data from the computer to the printer.

## Print Media

---

The media like paper, envelopes, and labels which can be used in a printer, a scanner, a fax or, a copier.

## PPM

---

Pages Per Minute (PPM) is a method of measurement for determining how fast a printer works, meaning the number of pages a printer can produce in one minute.

## PRN file

---

An interface for a device driver, this allows software to interact with the device driver using standard input/output system calls, which simplifies many tasks.

## Protocol

---

A convention or standard that controls or enables the connection, communication, and data transfer between two computing endpoints.

## PS

---

See PostScript.

## PSTN

---

The Public-Switched Telephone Network (PSTN) is the network of the world's public circuit-switched telephone networks which, on industrial premises, is usually routed through the switchboard.

## RADIUS

---

Remote Authentication Dial In User Service (RADIUS) is a protocol for remote user authentication and accounting. RADIUS enables centralized management of authentication data such as usernames and passwords using an AAA (authentication, authorization, and accounting) concept to manage network access.

## Resolution

---

The sharpness of an image, measured in Dots Per Inch (DPI). The higher the dpi, the greater the resolution.

## SMB

---

Server Message Block (SMB) is a network protocol mainly applied to share files, printers, serial ports, and miscellaneous communications between nodes on a network. It also provides an authenticated Inter-process communication mechanism.

## SMTP

---

Simple Mail Transfer Protocol (SMTP) is the standard for e-mail transmissions across the Internet. SMTP is a relatively simple, text-based protocol, where one or more recipients of a message are specified, and then the message text is transferred. It is a client-server protocol, where the client transmits an email message to the server.

## SSID

---

Service Set Identifier (SSID) is a name of a wireless local area network (WLAN). All wireless devices in a WLAN use the same SSID in order to communicate with each other. The SSIDs are case-sensitive and have a maximum length of 32 characters.

## Subnet Mask

---

The subnet mask is used in conjunction with the network address to determine which part of the address is the network address and which part is the host address.

## TCP/IP

---

The Transmission Control Protocol (TCP) and the Internet Protocol (IP); the set of communications protocols that implement the protocol stack on which the Internet and most commercial networks run.

## TCR

---

Transmission Confirmation Report (TCR) provides details of each transmission such as job status, transmission result and number of pages sent. This report can be set to print after each job or only after failed transmissions.

## TIFF

---

Tagged Image File Format (TIFF) is a variable-resolution bitmapped image format. TIFF describes image data that typically come from scanners. TIFF images make use of tags, keywords defining the characteristics of the image that is included in the file. This flexible and platform-independent format can be used for pictures that have been made by various image processing applications.

## Toner Cartridge

---

A kind of bottle or container used in a machine like a printer which contains toner. Toner is a powder used in laser printers and photocopiers, which forms the text and images on the printed paper. Toner can be fused by a combination of heat/pressure from the fuser, causing it to bind to the fibers in the paper.

## TWAIN

---

An industry standard for scanners and software. By using a TWAIN-compliant scanner with a TWAIN-compliant program, a scan can be initiated from within the program. It is an image capture API for Microsoft Windows and Apple Mac operating systems.

## UNC Path

---

Uniform Naming Convention (UNC) is a standard way to access network shares in Window NT and other Microsoft products. The format of a UNC path is:  
\\<servername>\<sharename>\<Additional directory>

## URL

---

Uniform Resource Locator (URL) is the global address of documents and resources on the Internet. The first part of the address indicates what protocol to use, the second part specifies the IP address or the domain name where the resource is located.

## USB

---

Universal Serial Bus (USB) is a standard that was developed by the USB Implementers Forum, Inc., to connect computers and peripherals. Unlike the parallel port, USB is designed to concurrently connect a single computer USB port to multiple peripherals.

## Watermark

---

A watermark is a recognizable image or pattern in paper that appears lighter when viewed by transmitted light. Watermarks were first introduced in Bologna, Italy in 1282; they have been used by papermakers to identify their product, and also on postage stamps, currency, and other government documents to discourage counterfeiting.

## WEP

---

Wired Equivalent Privacy (WEP) is a security protocol specified in IEEE 802.11 to provide the same level of security as that of a wired LAN. WEP provides security by encrypting data over radio so that it is protected as it is transmitted from one end point to another.

## WIA

---

Windows Imaging Architecture (WIA) is an imaging architecture that is originally introduced in Windows Me and Windows XP. A scan can be initiated from within these operating systems by using a WIA-compliant scanner.

## WPA

---

Wi-Fi Protected Access (WPA) is a class of systems to secure wireless (Wi-Fi) computer networks, which was created to improve upon the security features of WEP.

## WPA-PSK

---

WPA-PSK (WPA Pre-Shared Key) is special mode of WPA for small business or home users. A shared key, or password, is configured in the wireless access point (WAP) and any wireless laptop or desktop devices. WPA-PSK generates a unique key for each session between a wireless client and the associated WAP for more advanced security.

## WPS

---

The Wi-Fi Protected Setup (WPS) is a standard for establishing a wireless home network. If your wireless access point supports WPS, you can configure the wireless network connection easily without a computer.

## XPS

---

XML Paper Specification (XPS) is a specification for a Page Description Language (PDL) and a new document format, which has benefits for portable document and electronic document, developed by Microsoft. It is an XML-based specification, based on a new print path and a vector-based device-independent document format.

# Index

## A

---

accessories	
installing	94
ordering	83
accounting	300
address book	298
editing	255
general setup	239
group	298
group editing	256
group registering	256
individual	298
registering	255
using	255
address book setup	255
administrator's setup	242
AirPrint	203
AnyWeb Print	303
authority	300
authorized users	
registering	259

## B

---

buttons	
Darkness	21
eco	21
id copy	21
numeric keypad	21, 22
scan to	21

## C

---

certificate	299
cleaning	
inside	99
outside	98
pickup roller	101
scan unit	102
cleaning a machine	98
clear button	22
control panel	21
touch screen	33
convention	10
copy	
general setup	215
setting	298
copying	

basic copying	64
reducing or enlarging copies	66

## D

---

default settings	
tray setting	52
device options	94
direct printing utility	271
document box	247
general setup	247
driver installation	169
Unix	174

## E

---

easy document creator	283, 305
Eco	244
eco printing	61
email address	251
searching	252
storing	251
entering character	253
error message	122
external authentication server	300

# Index

## F

---

favorites settings, for printing	60
fax	
address book	298
automatic redialing	286
canceling a reserved fax job	288
changing the receive modes	290
delaying a fax transmission	287
forwarding a received fax to another destination	289
forwarding a sent fax to another destination	288
general setup	221
receiving a fax in the computer	290
receiving in Answering Machine mode	291
receiving in DRPD mode	292
receiving in Fax mode	291
receiving in secure mode	292
receiving in Tel mode	291
receiving with ext. telephone	291
redialing the last number	286
sending a fax from the computer	287
sending faxes on both sides of paper	289
fax feature	286

fax sending	
multi sending	71
faxing	
adjusting darkness	73
adjusting resolution	72
preparing to fax	70
receiving in Fax mode	72
features	5
machine features	211
print media feature	132
filtering	300
IPv6	300
MAC	300
firmware	301
front view	18
<b>G</b>	
general icons	10
general settings	229
glossary	351
google cloud printing	209
<b>H</b>	
help button	22

http	153
HTTP settings	299
<b>I</b>	
id copy	67
IPP settings	299
<b>J</b>	
jam	
clearing original document	115
clearing paper	107
tips for avoiding paper jams	106
<b>L</b>	
LCD display	
browsing the machine status	215, 220, 237
link	301
Linux	
common Linux problems	342
driver installation for network connected	173
driver installation for USB cable connected	160
driver reinstallation for USB cable connected	161



# Index

printer properties	274	using SetIP	165	Mac	173
printing	274	machine information	215, 220, 237	UNIX	174
scanning	285	machine setup		Windows	169
system requirements	138	machine status	215, 220, 237	general setup	239
using SetIP	166	Macintosh		installing environment	139
linux scanning	285	scanning	284	introducing network programs	163
loading		maintenance parts	84	IPv4 configuration	164
paper in multi-purpose tray	46	managing		IPv6 configuration	166
paper in the tray1	44	address book	298	SetIP program	164, 165, 166, 184
special media	48	application	301	wired network setup	164
loading originals	54	user	300	wireless network setup	176
log	301	memory/hard drive feature	293	n-up printing	
LPR/LPD settings	299	menu		Mac	272
		printer on	248	<b>O</b>	
<b>M</b>		menu overview	28	optional tray	
Mac		Mopria	201	loading paper	44
common Mac problems	341	multi-purpose tray		ordering	83
driver installation for network connected	173	loading	46	output support	53
driver installation for USB cable connected	158	using special media	48	overlay printing	
driver reinstallation for USB cable connected	159	<b>N</b>		create	267
printing	272	network		delete	268
system requirements	137	driver installation		print	267
		Linux	173		

# Index

## P

---

placing a machine		general information	312	UNIX	275
adjusting the altitude	250	PrinterOn	207	printing feature	260
postScript driver		printing		problem	
troubleshooting	343	changing the default print settings	260	operating system problems	340
preparing originals type	53	duplex	298	problems	
print		Linux	274	copying problems	335
general setup	213	Mac	272	faxing problems	338
mobile OS	200	margin	298	paper feeding problems	321
mobileprint	200	multiple pages on one sheet of paper		power problems	322
print media		Mac	272	printing problems	323
card stock	51	paper orientation	298	printing quality problems	327
envelope	49	printing a document		scanning problems	336
guidelines	42	Windows	57		
labels	50	printing on both sides of paper		<b>R</b>	
output support	132	Mac	273	Raw TCP/IP settings	299
preprinted paper	51	printing to a file	262	rear view	20
setting the paper size	52	setting as a default machine	261	register	
setting the paper type	52	special printer features	263	PrinterOn	207
special media	48	UNIX	275	regulatory information	140
print menu	213	USB memory	75	reports	
printer preferences		using direct printing utility	271	machine information	215, 221, 222, 223, 226, 229, 237
Linux	274	printing a document		requirements	
printer status		Linux	274	SyncThru™ Web Service	296
		Mac	272		

# Index

reset button	22	Scanning to email	279	print media	132
resolution		Scanning to FTP/SMB server	280	status	21, 22
faxing	72	Scanning using the WIA driver	283	Storing	251
		USB flash memory	76	supplies	
<b>S</b>		secu printing	63	available supplies	82
<hr/>		security		estimated toner cartridge life	86
safety		system	299	monitoring the supplies life	96
information	11	service contact numbers	344	ordering	82
symbols	11	SetIP program	164, 184	replacing toner cartridge	89
samsung cloud printing	204	settings		SyncThru™ Web Service	296
samsung printer experience	314	copy	298	accounting	300
Samsung Printer Status	312	current	298	address book tab	298
scan		fax	298	application management	301
email server	299	HTTP	299	configuring	299
general setup	225	machine	298	connecting to	296
scan feature	277	margin	298	copy	298
Scanning		network	299	external authentication server	300
Scanning with Samsung Scan Assistant	283	printer	298	fax	298
scanning		scan	298	information tab	298
basic information	277	security	299	log	301
Linux scanning	285	network	299	maintenance tab	301
Macintosh	284	SyncThru™ Web Service	299	network	299
Scanning from image editing program	282	Special features	249	printer	298
Scanning from network connected machine	278, 281	specifications	130	requirements	296

# Index

scan	298	<b>U</b>		using	
security tab	299	understanding the status LED	120	keyboard	254
settings	298	UNIX		PrinterOn	208
settings tab	298	driver installation for network connected		using help	60, 273
user access control	300	174		<b>W</b>	
user profile	300	printing	275	watermark	
what is	296	Unix		create	266
<b>T</b>		system requirements	137	delete	266
toner cartridge		usage		edit	266
estimated life	86	counter	298	Windows	
handling instructions	85	supplies	298	common Windows problems	340
non-Samsung and refilled	85	USB	245	driver installation for network connected	
redistributing toner	87	USB cable		169	
replacing the cartridge	89	driver installation	24, 26, 158, 160	driver installation for USB cable connected	
storing	85	driver reinstallation	159, 161	24,	26
touch screen		USB flash memory		system requirements	136
keyboard	254	data backup	77	using SetIP	164, 184
tray		managing	78	wireless	
adjusting the width and length	43	printing	75	WPS	
changing the tray size	43	scanning	76	disconnecting	178
loading paper in multi-purpose tray	46	user		PBC mode	178
ordering an optional tray	83	managing	300	disconnecting	
setting the paper size and type	52	profile	300	PBC mode	178
		user access control	300	wireless network	

# Index

---

network cable	184
WSD settings	299