

EPSON®

24-Pin Dot Matrix Printer

LQ-670

All rights reserved. No part of this publication may be reproduced, stored in a retrieval system, or transmitted in any form or by any means, electronic, mechanical, photocopying, recording, or otherwise, without the prior written permission of SEIKO EPSON CORPORATION. The information contained herein is designed only for use with this EPSON printer. EPSON is not responsible for any use of this information as applied to other printers.

Neither SEIKO EPSON CORPORATION nor its affiliates shall be liable to the purchaser of this product or third parties for damages, losses, costs, or expenses incurred by the purchaser or third parties as a result of: accident, misuse, or abuse of this product or unauthorized modifications, repairs, or alterations to this product, or (excluding the U.S.) failure to strictly comply with SEIKO EPSON CORPORATION's operating and maintenance instructions.

SEIKO EPSON CORPORATION shall not be liable for any damages or problems arising from the use of any options or any consumable products other than those designated as Original EPSON Products or EPSON Approved Products by SEIKO EPSON CORPORATION.

EPSON and EPSON ESC/ P are registered trademarks and EPSON ESC/ P 2 is a trademark of SEIKO EPSON CORPORATION.

Microsoft and Windows are registered trademarks of Microsoft Corporation.

IBM is a registered trademark of International Business Machines Corporation.

***General Notice:** Other product names used herein are for identification purposes only and may be trademarks of their respective owners. EPSON disclaims any and all rights in those marks.*

Copyright © 1996 by SEIKO EPSON CORPORATION, Nagano, Japan.



Printed on Recycled Paper.

User's Guide

Printer Parts

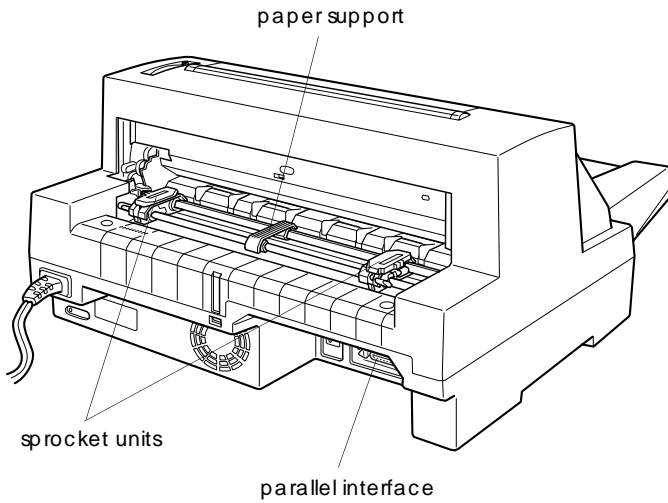
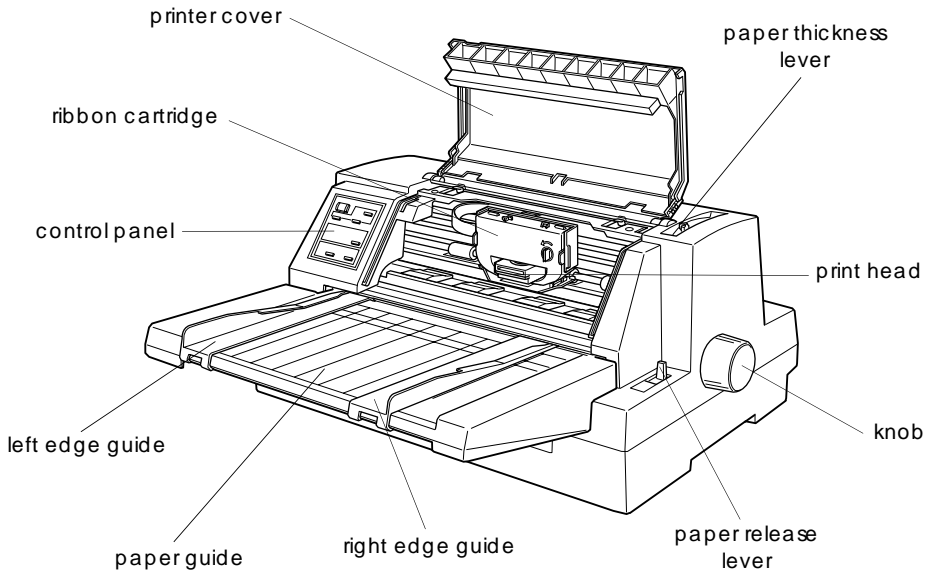

FCC Compliance Statement For United States Users

This equipment has been tested and found to comply with the limits for a Class B digital device, pursuant to Part 15 of the FCC Rules. These limits are designed to provide reasonable protection against harmful interference in a residential installation. This equipment generates, uses, and can radiate radio frequency energy and, if not installed and used in accordance with the instructions, may cause harmful interference to radio or television reception. However, there is no guarantee that interference will not occur in a particular installation. If this equipment does cause interference to radio and television reception, which can be determined by turning the equipment off and on, the user is encouraged to try to correct the interference by one or more of the following measures.

- Reorient or relocate the receiving antenna
- Increase the separation between the equipment and receiver
- Connect the equipment into an outlet on a circuit different from that to which the receiver is connected
- Consult the dealer or an experienced radio/ TV technician for help.

WARNING

The connection of a non-shielded equipment interface cable to this equipment will invalidate the FCC Certification of this device and may cause interference levels which exceed the limits established by the FCC for this equipment. It is the responsibility of the user to obtain and use a shielded equipment interface cable with this device. If this equipment has more than one interface connector, do not leave cables connected to unused interfaces.

Changes or modifications not expressly approved by the manufacturer could void the user's authority to operate the equipment.

For Canadian Users

This Class B digital apparatus meets all requirements of the Canadian Interference-Causing Equipment Regulations.

Cet appareil numérique de la classe B respecte toutes les exigences du Règlement sur le matériel brouilleur du Canada.

Declaration of Conformity

According to ISO/IEC Guide 22 and EN 45014

Manufacturer: SEIKO EPSON CORPORATION
Address: 3-5, Owa 3-chome, Suwa-shi,
Nagano-ken 392 Japan

Representative: EPSON EUROPE B.V.
Address: Prof. J. H. Bavincklaan 5 1183 AT Amstelveen
The Netherlands

Declares that the Product:

Product Name:	Dot Matrix Printer
Type Name:	LQ-670
Model:	P960A

Conforms to the following Directive(s) and Norm(s):

Directive 73/ 23/ EEC:

EN 60950

Directive 89/ 336/ EEC:

EN 55022 Class B

EN 61000-3-2

EN 61000-3-3

EN 50082-1

IEC 801-2

IEC 801-3

IEC 801-4

April 1997

M. Hamamoto
President of EPSON EUROPE B.V.

Safety Information

Important Safety Instructions

Read all of these instructions and save them for later reference. Follow all warnings and instructions marked on the printer.

- Do not place the printer on an unstable surface or near a radiator or heat source.
- Place the printer on a flat surface. The printer will not operate properly if it is tilted or at an angle.
- Do not block or cover the openings in the printer's cabinet. Do not insert objects through the slots.
- Use only the type of power source indicated on the printer's label.
- Connect all equipment to properly grounded power outlets. Avoid using outlets on the same circuit as photocopiers or air control systems that regularly switch on and off.
- Do not use a damaged or frayed power cord.
- If you use an extension cord with the printer, make sure the total ampere rating of the devices plugged into the extension cord does not exceed the cord's ampere rating. Also, make sure the total of all devices plugged into the wall outlet does not exceed 15 amperes.
- Unplug the printer before cleaning. Clean with a damp cloth only. Do not spill liquid on the printer.
- Except as specifically explained in this guide, do not attempt to service the printer yourself.

- ❑ Unplug the printer and refer servicing to qualified service personnel under the following conditions:

If the power cord or plug is damaged; if liquid has entered the printer; if the printer has been dropped or the cabinet damaged; if the printer does not operate normally or exhibits a distinct change in performance. Adjust only those controls that are covered by the operating instructions.

- ❑ If you plan to use the printer in Germany, observe the following:

To provide adequate short-circuit protection and over-current protection for this printer, the building installation must be protected by a 16 Amp circuit breaker.

Bei Anschluß des Druckers an die Stromversorgung muß sichergestellt werden, daß die Gebäudeinstallation mit einem 16 A-Überstromschalter abgesichert ist.



ENERGY STAR Compliance

As an ENERGY STAR Partner, EPSON has determined that this product meets the ENERGY STAR guidelines for energy efficiency.

The International ENERGY STAR Office Equipment program is a voluntary partnership with the computer and office equipment industry to promote the introduction of energy-efficient personal computers, monitors, printers, fax machines, and copiers in an effort to reduce air pollution caused by power generation.

For United Kingdom Users

Use of options

Epson (UK) Limited shall not be liable against any damages or problems arising from the use of any options or consumable products other than those designated as Original EPSON Products or EPSON Approved Products by Epson (UK) Limited.

Safety information



Warning: *This appliance must be earthed. Refer to rating plate for voltage and check that the appliance voltage corresponds to the supply voltage.*

Important: *The wires in the mains lead fitted to this appliance are coloured in accordance with the following code:*

Green and yellow — Earth
Blue — Neutral
Brown — Live

If you have to fit a plug:

As the colours of the mains lead of this appliance may not match coloured markings used to identify the terminals in a plug, please proceed as follows:

The green and yellow wire must be connected to the terminal in the plug which is marked with the letter E or the Earth symbol (\perp).

The blue wire must be connected to the terminal in the plug marked with the letter N.

The brown wire must be connected to the terminal in the plug marked with the letter L.

If damage occurs to the plug, replace the cord set or consult a qualified electrician.

Replace fuses only with a fuse of the correct size and rating.

Contents

Introduction

Features	1
Options	2
How to Use This Manual	3
Warnings, Cautions, and Notes	4

Chapter 1 Setting Up the Printer

Unpacking the Printer	1-2
Choosing a Place for the Printer	1-3
Assembling the Printer	1-5
Installing the knob	1-5
Installing the ribbon cartridge	1-6
Attaching the paper guide	1-9
Plugging in the Printer	1-9
Connecting the Printer to Your Computer	1-10

Chapter 2 Setting Up Your Software

For Windows 95 Users	2-2
Installing the printer driver using plug-and-play	2-2
Installing the printer driver using My Computer	2-4
Using the printer driver	2-6
For Windows 3.1 Users	2-9
Installing the printer driver using Program Manager	2-9
Using the printer driver	2-10
For DOS Program Users	2-12
Installing a printer driver for DOS applications	2-12
Using the EPSON Remote! printer utility	2-14

Chapter 3 Paper Handling

Selecting a Paper-Feeding Method	3-2
Paper-feeding methods and paper types	3-3
Setting the paper release lever	3-4
Adjusting the Paper Thickness Lever	3-5
Using Single Sheets	3-6
Using Continuous Paper	3-9
Positioning your continuous paper supply	3-10
Loading continuous paper with the tractor	3-11
Using the tear-off function	3-16
Removing continuous paper	3-20
Using Multi-part Forms	3-20
Using Labels	3-21
Using Envelopes	3-23
Using Postcards	3-24
Switching Between Continuous Paper and Single Sheets	3-25
Switching to single sheets	3-25
Switching to continuous paper	3-26
Using Micro Adjust	3-27
Adjusting the loading position	3-27
Adjusting the printing position	3-29
Adjusting the tear-off position	3-31

Chapter 4 Using the Control Panel

Basic Control Panel Functions	4-2
Lights	4-3
Buttons	4-4
Advanced Control Panel Functions	4-7
Using the Default-Setting Mode	4-9
Default-setting mode options	4-9
Changing the default settings	4-14
Using Quiet Mode	4-16

Chapter 5 *Using Printer Options*

Cut-Sheet Feeders	5-2
Installing the cut-sheet feeder	5-3
Loading paper from the cut-sheet feeder	5-6
Switching between the tractor and the cut-sheet feeder	5-13
Loading paper manually from the sheet guide	5-14
Roll Paper Holder	5-15
Installing the roll paper holder	5-15
Loading a roll of paper	5-17
Interface Cards	5-19
Installing an interface card	5-19
Using a serial interface card (C82305* or C82306*)	5-21

Chapter 6 *Maintenance and Transportation*

Replacing the Ribbon Cartridge	6-2
Cleaning the Printer	6-5
Transporting the Printer	6-6

Chapter 7 *Troubleshooting*

Using the Error Indicators	7-3
Printing a Self Test	7-4
Using Hex Dump Mode	7-5
Problems and Solutions	7-6
Power supply	7-7
Paper handling	7-8
Operation	7-16
Printout	7-18
Clearing a Paper Jam	7-24
Using Bidirectional Adjustment Mode	7-24

Appendix A **Specifications**

Technical Specifications	A-2
Printing	A-2
Paper	A-4
Mechanical	A-9
Electrical	A-10
Environmental	A-10
Safety approvals	A-11
CE marking	A-11
Parallel Interface Specifications	A-12
Forward channel	A-12
Reverse channel	A-12
Optional Cut-Sheet Feeder Specifications	A-13

Appendix B **Command Lists and Character Tables**

EPSON ESC/ P 2 Control Codes	B-2
Barcode command	B-3
IBM 2390 Plus Emulation Control Codes	B-6
Character Tables in EPSON ESC/ P 2 Mode	B-7

Appendix C Contacting Customer Support

For United States Users	C-2
Electronic support services	C-3
For United Kingdom and the Republic of Ireland Users	C-4
Enquiry Desk	C-4
Customer Support	C-4
Faxon EPSON	C-5
EPtec - Bulletin Board Service for latest drivers and utilities	C-5
World Wide Web	C-5
For Australian Users	C-6
EPSON FAXBACK	C-6
EPSON Bulletin Board System	C-6
Internet URL http:// www.epson.com.au	C-6
Your dealer	C-6
EPSON Helpdesk	C-7
For Singapore Users	C-7
For Hong Kong Users	C-8
Internet home page	C-8
Electronic bulletin board system	C-8
Technical Support Hotline	C-8
For Philippines Users	C-9

Glossary

Index

Introduction

Your new EPSON® 24-pin dot matrix printer offers high performance with a wide range of features in a compact design. You will find the same high-quality printing and ease of operation you have come to expect from EPSON printers.

Features

Here are some of the features that make your printer a great value:

- ❑ High-speed draft mode printing of up to 300 characters per second (cps) at 10 characters per inch (cpi)
- ❑ The ability to handle a wide range of paper types, including single sheets, continuous paper, multi-part forms (one original plus up to four copies), labels, envelopes, and postcards
- ❑ High-precision printouts even on multi-part forms, made possible by keeping the paper flat, not rolled, during printing
- ❑ Easy paper handling for both single sheets and continuous paper
- ❑ A convenient control panel that allows direct selection of fonts
- ❑ Eight barcode fonts and four scalable fonts, as well as one draft and nine letter-quality bitmap fonts
- ❑ Support of advanced EPSON ESC/ P 2™ commands and IBM® 2390 Plus emulation
- ❑ A large printable area: 70 lines with A4 size paper and 66 lines with letter size paper

- ❑ Software, including a printer driver and a remote control panel utility, that lets you change printer settings quickly and easily
- ❑ Bidirectional communication with IEEE 1284 Nibble Mode support.

Options

The following options are available for your printer:

- ❑ High Capacity (C80678*) and Second Bin (C80679*) cut-sheet feeders. The high-capacity cut-sheet feeder automatically feeds up to 150 sheets of plain paper without reloading. The second-bin cut-sheet feeder allows you to feed an additional 50 sheets. You can create a double-bin cut-sheet feeder by combining the high-capacity and second-bin feeders. With the double-bin feeder, you can use two different paper types or sizes.
- ❑ Roll Paper Holder (#8310). Allows you to use your printer with 8.5-inch roll paper like that used with telex machines. (This option is available only in some countries.)
- ❑ Interface cards. Available to supplement the printer's built-in parallel interface.

How to Use This Manual

This manual provides illustrated, step-by-step instructions for setting up and operating your printer.

Chapter 1 contains information on unpacking, setting up, and connecting the printer. Be sure to read this chapter first.

Chapter 2 describes how to set up your software, which includes a printer driver for Microsoft® Windows® operating systems and the EPSON Remote! printer utility for DOS.

Chapter 3 explains how to load and use single sheets, continuous paper, and other types of paper.

Chapter 4 contains information on controlling the printer using the control panel. To change many of the printer's default settings, see "Using the Default-Setting Mode" in this chapter.

Chapter 5 explains how to use optional accessories with your printer.

Chapter 6 provides maintenance information, including transportation guidelines.

Chapter 7 contains troubleshooting information. If the printer does not operate properly or the printed results are not what you expect, see this chapter for a list of problems and solutions.

Appendix A provides specifications for the printer and the optional cut-sheet feeder.

Appendix B lists the printer's commands and character tables.

Appendix C lists the best methods for obtaining help with or more information about EPSON products and services.

At the end of the manual, you'll find a glossary and an index.

Warnings, Cautions, and Notes

This guide uses the following conventions:



Warnings must be followed to avoid bodily injury.



Cautions must be observed to avoid damage to your equipment.

Notes contain important information and useful tips on the operation of your printer.

Unpacking the Printer 1-2

Choosing a Place for the Printer 1-3

Assembling the Printer 1-5

 Installing the knob 1-5

 Installing the ribbon cartridge 1-6

 Attaching the paper guide 1-9

Plugging in the Printer 1-9

Connecting the Printer to Your Computer 1-10

This chapter describes how to set up your printer and connect it to your computer.

Unpacking the Printer

Besides this guide, your printer box should include an EPSON printer driver disk, a Notice Sheet, and the following items:

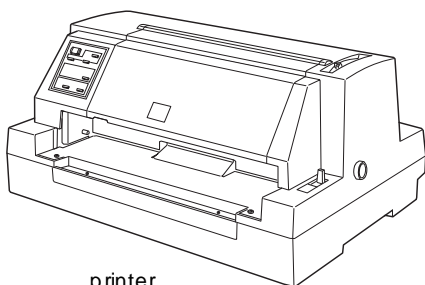

printer

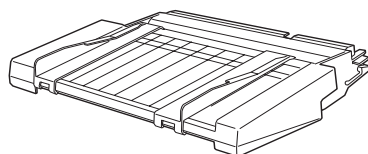

paper guide

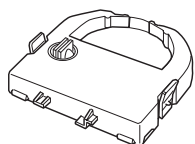

ribbon cartridge



knob



power cord

Note:

Depending on your printer model, the power cord may be permanently attached to the printer. Also, the shape of the power cord plug varies depending on the country in which you bought your printer; be sure the plug you have is the right one for your location.

You must remove all protective materials packed around and inside your printer before you set it up and turn on the power. Follow the directions on the Notice Sheet (packed with printer) to remove these materials.

Save all packing and protective materials in case you need to ship the printer in the future. It should always be transported in its original packaging or equivalent materials.



Caution:

- Be sure to remove all protective materials before you turn on the printer.*

- There are several models of the printer designed for different voltages, and it is not possible to adjust the printer for use at another voltage. If the label on the back of the printer does not show the correct voltage for your country, contact your dealer.*

Choosing a Place for the Printer

Follow the guidelines below when selecting a location for your printer.

- Place the printer on a flat, stable surface. The printer will not operate properly if it is tilted or at an angle.

- Place the printer where you can easily connect it to a network interface cable, if necessary.

- Leave adequate room around the printer for easy operation and maintenance.

- Avoid using or storing the printer in places subject to rapid changes in temperature and humidity. Also keep it away from direct sunlight, strong light, heat sources, or excessive moisture or dust.

- Avoid places subject to shocks and vibrations.

- Place the printer near a wall outlet where you easily unplug the power cord.

Note for French-speaking users:

Placez l'imprimante près d'une prise de contact où la fiche peut être débranchée facilement.

- ❑ Avoid electrical outlets controlled by wall switches or automatic timers. An interruption in power can erase information in the memory of your printer or computer. Also avoid outlets on the same circuit as large motors or other appliances that can cause voltage fluctuations.
- ❑ Keep the entire computer system away from potential sources of electromagnetic interference, such as loudspeakers or the base units of cordless telephones.
- ❑ Use a grounded power outlet; do not use an adapter plug.
- ❑ Make sure the paper path is clear and unobstructed before you print on continuous paper. See Chapter 3 for details.

If you plan to use a printer stand, follow these guidelines:

- ❑ Use a stand that supports at least 18 kg (39.6 lb).
- ❑ Never use a stand that tilts the printer. The printer should always be kept level.
- ❑ Position your printer's power cord and interface cable so they do not interfere with paper feeding. If possible, secure the cables to a leg of the printer stand.

Assembling the Printer

Installing the knob

Insert the knob into the hole on the side of the printer and rotate it slowly until it slips onto the shaft. Then firmly push in the knob.

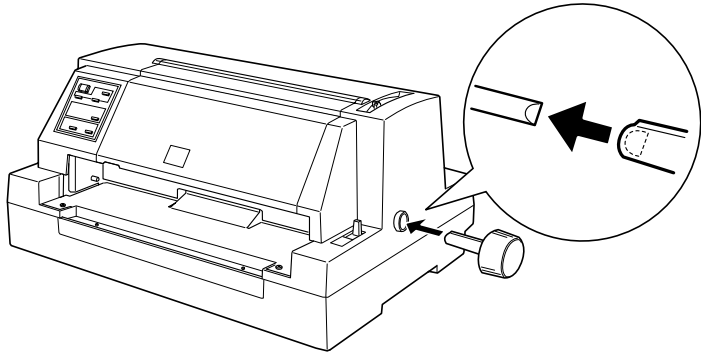

Installing the ribbon cartridge

Before installing the ribbon cartridge, make sure that the power cord is not plugged into an electrical outlet.

To install the ribbon cartridge, remove it from its packaging and then follow these steps:

1. Open the printer cover by gently lifting up the notch on its left side.

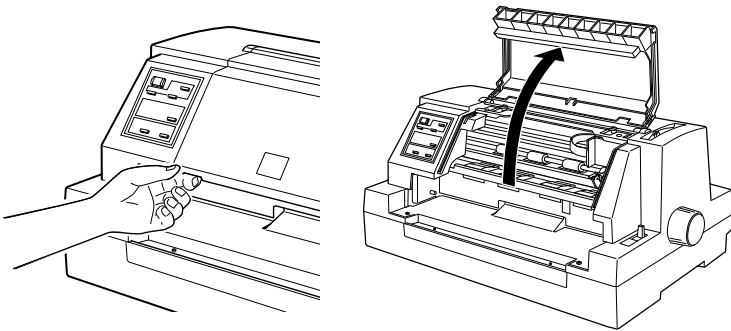

Warning:

Never move the print head while the printer is turned on; this can damage the printer. Also, if you just used the printer, the print head may be hot. Let it cool for a few minutes before touching it.

2. Slide the print head to the middle position where the front metal plate is indented as shown below.

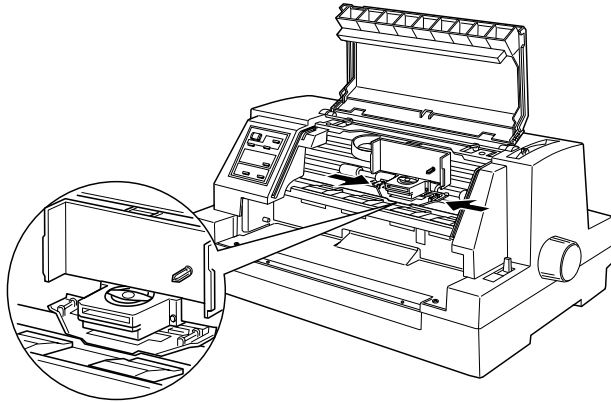

3. Turn the ribbon-tightening knob in the direction of the arrow to take up any slack in the ribbon.

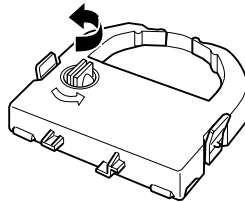

4. Hold the ribbon cartridge with the exposed ribbon down and the ribbon-tightening knob facing you, and guide the ribbon under the print head. Then snap the cartridge into place so that the tabs on both sides of the cartridge fit into the notches in the cartridge holder.

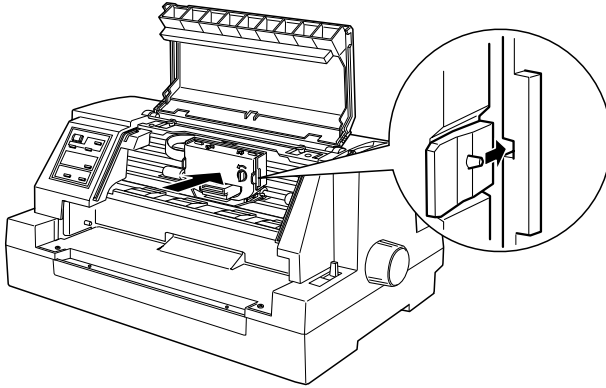

5. Turn the ribbon-tightening knob again to remove any slack in the ribbon and to make sure the ribbon moves freely.

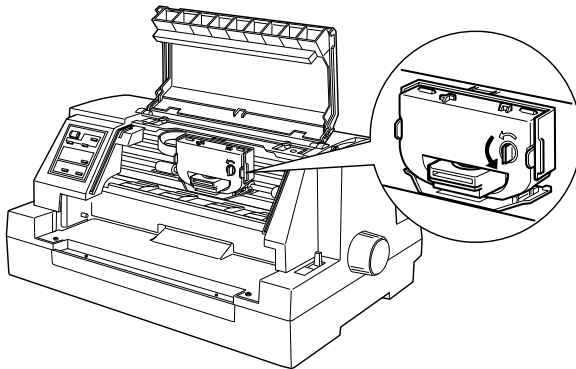

6. Close the printer cover.

Attaching the paper guide

To attach the paper guide, slide the slots on the paper guide all the way onto the mounting pegs in the printer as shown below.

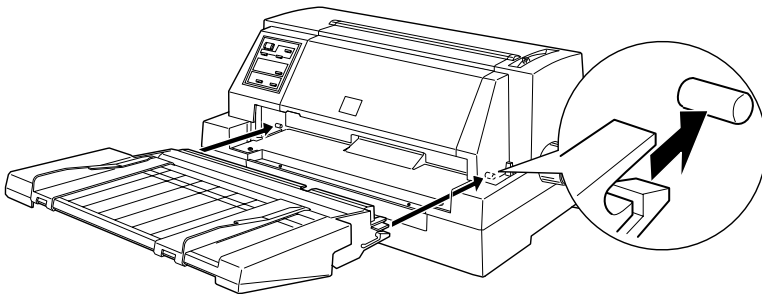

Plugging in the Printer

1. Make sure the printer is turned off. The printer is off when the top of the **Operate** button is flush with the raised tabs on either side of the button.
2. Check the label on the back of the printer to make sure its voltage matches that of your electrical outlet. Also make sure the plug on your printer's power cord matches your electrical outlet.



Caution:

It is not possible to change the printer's voltage. If the rated voltage and your outlet voltage do not match, contact your dealer for assistance. Do not plug in the power cord.

3. If the power cord is not attached to the printer, plug the appropriate end into the AC inlet on the back of the printer.
4. Plug the power cord into a properly grounded electrical outlet.

Connecting the Printer to Your Computer

To connect your computer to your printer's built-in parallel interface, you need a shielded, twisted-pair parallel cable with a D-SUB, 25-pin, male connector for your computer and a 36-pin Centronics[®] compatible connector for the printer.

If your computer requires a different type of printer interface, you should be able to use one of the optional interfaces described on page 5-19.

Follow the steps below to connect the printer to your computer using the built-in parallel interface.

1. Make sure both the printer and computer are turned off.
2. Plug the cable connector securely into the printer's interface connector.

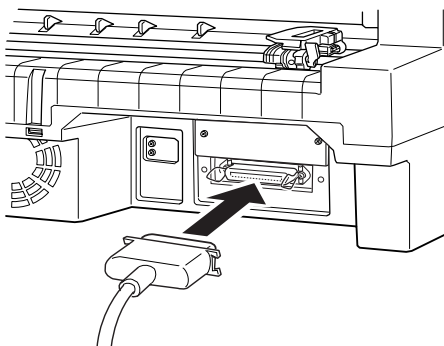

3. Squeeze the wire clips together until they lock in place on both sides of the connector.

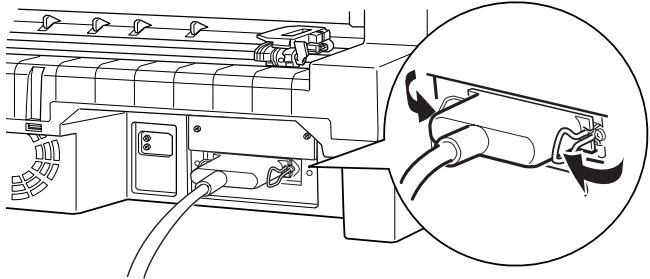

4. If your cable has a ground wire, connect it to the printer's ground connector as shown below.

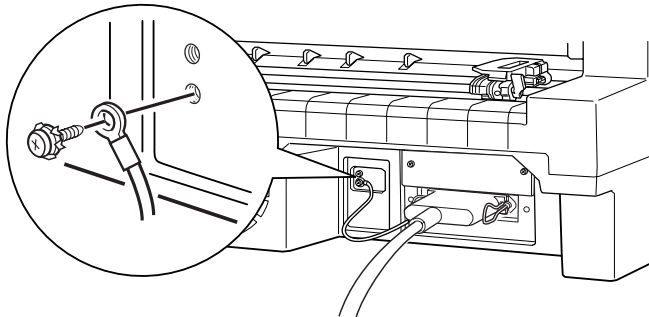

5. Plug the other end of the cable into the computer. (If the cable has a ground wire at the computer end, attach it to the ground connector at the back of the computer.)

Now see Chapter 2 for instructions on installing and using the printer driver.

Chapter 2

Setting Up Your Software

For Windows 95 Users	2-2
Installing the printer driver using plug-and-play	2-2
Installing the printer driver using My Computer	2-4
Using the printer driver	2-6
For Windows 3.1 Users	2-9
Installing the printer driver using Program Manager	2-9
Using the printer driver	2-10
For DOS Program Users	2-12
Installing a printer driver for DOS applications	2-12
Using the EPSON Remote! printer utility	2-14

The EPSON printer driver disk that comes with your printer includes the printer driver software and a printer utility.

A printer driver is software that allows your computer to control the printer. You need to install the printer driver so your software applications can take full advantage of the printer's capabilities.

For instructions on installing the printer driver, see the next section if you are using Windows 95, page 2-9 if you are using Windows 3.1, or page 2-12 if you are using a DOS program.

Note:

Before you install the printer driver or printer utility, it is best to make a backup copy of the EPSON printer driver disk.

For Windows 95 Users

You can install the printer driver using the Windows 95 plug-and-play feature or the My Computer icon, as described below.

Note:

You can install the printer driver using plug-and-play only if your computer has an IEEE-1284 compatible, bidirectional parallel port. See your computer documentation for more information.

Installing the printer driver using plug-and-play

Follow the steps below to install the printer driver using plug-and-play.

1. Make sure the printer is connected to your computer as described on page 1-10.
2. Turn off your printer and computer, if necessary.

3. First turn on your printer and then turn on the computer. Your computer begins loading Windows 95.
4. If you use a password, enter it at the prompt. You see the New Hardware Found screen.

Note:

If you do not see the New Hardware Found screen, follow the instructions under “Installing the printer driver using My Computer” on page 2-4.

5. Make sure the screen displays your printer model name. Then click the **Driver from disk provided by hardware manufacturer** radio button.

Note:

*The next time you turn on your computer after you install the driver, Windows 95 may display the New Hardware Found screen again. If so, select the **Do not install a driver** radio button and then click **OK**. This screen does not appear again.*

6. Click **OK**. You see the Install From Disk screen.
7. Insert the printer driver disk in a disk drive.
8. If you inserted the disk in drive A, click **OK**. Otherwise, change the drive letter in the Copy manufacturer’s files from box and click **OK**.
9. You can type a unique name for the printer in the Printer name box. We recommend that you keep the model name as shown.

To use the printer as the default printer for Windows 95 applications, select **Yes**. (**No** is the default setting.)

10. Click the **Finish** button. The program copies the files to your hard disk and adds an icon to the Printers folder using the printer model name or the name you selected.

Installing the printer driver using My Computer

If you have trouble installing the printer driver using the plug-and-play feature, follow the steps below to install it.

1. Make sure Windows 95 is running.
2. Double-click the **My Computer** icon.
3. Click **Printers**.
4. Double-click the **Add Printer** icon. You see the Add Printer Wizard screen.



5. Click the **Next** button.
6. Select the local or network printer setting; then click **Next**.

7. Click the **Have Disk** button to indicate you will install the driver supplied with your printer. The following screen appears:



8. Insert the printer driver disk in a disk drive.
9. If you inserted the disk in drive A, click **OK**. Otherwise, change the drive letter in the Copy manufacturer's files from box and click **OK**.
10. Select **EPSON LQ-670 ESC/P 2**, and click the **Next** button.
11. Choose the port you want to use with your printer (LPT1 is the default), and click the **Next** button. The following screen appears:

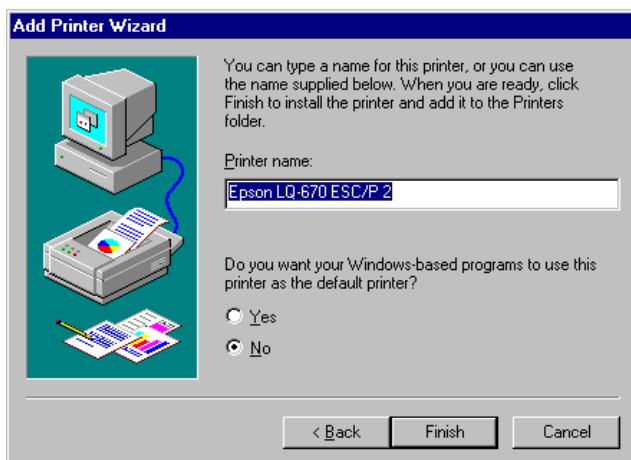

12. You can type a unique name for the printer in the Printer name box. We recommend that you keep the model name as shown.

Select the **Yes** or **No** radio button to indicate whether you want to use the printer as the default printer for Windows 95 applications.

13. Click **Finish**. The program copies the files to your hard disk and adds an icon to the Printers folder using the printer model name or the name you selected.



Using the printer driver

Before you start printing, you should make sure that the printer driver settings match your document requirements. While many Windows applications override the printer settings made with the driver, some do not.

See this section for instructions on how to access the printer driver, check the printer driver settings, and change settings if necessary.

Accessing the printer driver from Windows applications

When you access the printer driver from a Windows application, any settings you make apply only to the application you are using. The access method explained below is typical for many Windows applications, but the way you access your printer driver may differ depending on your application. See your application manual for details.

To access the printer driver, select **Print Setup** or **Print** from the File menu of your application software. If you choose **Print Setup**, you see your application's Print Setup dialog box. If you choose **Print**, you see your application's Print dialog box.

To access the printer driver, choose **Printer**, **Setup**, **Properties**, or **Options**, depending on the options available in your application. (You may need to choose a combination of these options.) The Paper and Graphics menus contain the printer driver settings. Click the tabs at the top of the menus to open them.

Accessing the printer driver from the Start menu

When you access the printer driver from the Windows 95 Start menu, the settings you make apply to any Windows applications you open afterward. To access the printer driver from the Start menu, follow these steps:

1. Click the **Start** button, and then point to **Settings**.
2. Click **Printers**.
3. Right-click your printer icon, and click **Properties**. The Properties window appears.
4. The Paper and Graphics menus contain the printer driver settings. Click the tabs at the top of the menus to open them.

Checking and changing printer driver settings

Before printing, check that the printer driver settings on the Paper and Graphics menus are appropriate for the kind of document you want to print, and change settings as needed. When you are finished making changes, click **OK** to apply the settings, or click **Restore Defaults** to return the settings to their factory defaults.

Paper menu

- Paper size Select the size of the paper loaded in the printer. If you don't see your paper size, use the scroll bar to scroll through the list. If your paper size is not included in the list, click **Custom** and enter the paper size in the dialog box that appears.
- Orientation Select **Portrait** or **Landscape**.
- Paper source Click the paper source you want to use.

Graphics menu

- Resolution Click the printing resolution you want.
- Dithering You can leave this option set to **Fine**, which is the default setting, or select another dithering pattern, depending on the kind of printout you want. The display to the left of the dithering options shows the effect of your setting.
- Intensity Move the slider to make your printout lighter or darker.

Once you've checked your printer driver settings, you are ready to print. If you have any trouble while printing, see Chapter 7, "Troubleshooting," for solutions.

For Windows 3.1 Users

Installing the printer driver using Program Manager

2

Follow the steps below to install the printer driver for Windows 3.1.

1. Make sure Windows 3.1 is running and the Program Manager window is open.
2. Insert the printer driver disk in a disk drive.
3. Choose **R**UN from the File menu. The following dialog box appears:

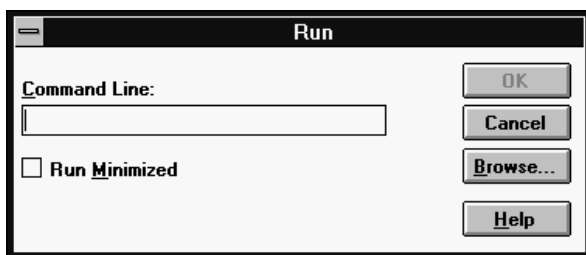

4. Type **A:\ SETUP** (or **B:\ SETUP**) and click **O**K. The EPSON Printer Driver Setup dialog box appears.
5. Select your printer and click **O**K. The installation program begins copying the printer driver files.

After a few moments, the installation program creates the EPSON program group in Windows.

6. When the installation is complete, click **O**K to exit the installation program.

Windows will now use the LQ-670 as its default printer on port LPT1. If you need to change the default printer or the port assignment, use the Control Panel Printers utility.

Using the printer driver

Before you start printing, you should make sure that the printer driver settings match your document requirements. While many Windows applications override the printer settings made with the driver, some do not.

See this section for instructions on how to access the printer driver, check the printer driver settings, and change settings if necessary.

Accessing the printer driver from Windows applications

When you access the printer driver settings from a Windows application, any settings you make apply only to the application you are using. The access method explained below is typical for many Windows applications, but the way you access your printer driver may differ depending on your application. See your application manual for details.

To access the printer driver settings, select **Print Setup** or **Print** from the File menu of your application software. If you choose **Print Setup**, you see your application's Print Setup dialog box, where you can make settings for paper size, paper source, and orientation. Some applications also feature an **Options** button, which allows you to access the printer driver's Options dialog box.

If you choose **Print**, you see your application's Print dialog box. To access the printer driver settings, choose **Printer**, **Setup**, or **Options**, depending on the options available in your application software. (You may need to choose a combination of these options.)

Note:

Your application software may let you access only a portion of the printer driver.

Accessing the printer driver from the Control Panel

When you access the printer driver from the Windows 3.1 Control Panel, the settings you make apply to any Windows applications you open afterward. To access the printer driver from the Control Panel, follow these steps:

1. In the Main window, double-click the **Control Panel** icon.
2. Double-click the **Printers** icon. The Printers dialog box appears.
3. Make sure your printer is highlighted, then click **Setup**. The printer driver settings window appears.

Checking and changing printer driver settings

Before printing, check that the printer driver settings are appropriate for the kind of document you want to print, and change settings as needed. When you are finished making changes, click **OK** to apply the settings, or click **Cancel** to cancel your changes.

If you accessed the printer driver from your application, some of the settings below may appear in your application's Page Setup dialog box. If you accessed the driver from the Control Panel, these settings appear in the printer driver settings window.

- | | |
|-------------------------------------|------------------------------------------------------------------------------------------------------------------------------------------------------------------------------------------------------------------------------------------------------------------------------|
| <input type="checkbox"/> Resolution | Click the printing resolution you want. |
| <input type="checkbox"/> Paper Size | Select the size of the paper loaded in the printer. If you don't see your paper size, use the scroll bar to scroll through the list. If your paper size is not included in the list, click User Defined Size and enter the paper size in the dialog box that appears. |

- Paper Source Click the paper source you want to use.
- Orientation Select **Portrait** or **Landscape**. The diagram on the screen changes according to the orientation you select.

To access the following settings from your application, you may need to click **Printer**, **Setup**, **Options**, or some combination of these buttons. If you accessed the driver from the Control Panel, click **Options** to access these settings.

- Dithering You can leave this option set to **Coarse**, which is the default setting, or select another dithering pattern depending on the kind of printout you want.
- Intensity Control Move the slider to make your printout lighter or darker.

Once you've checked your printer driver settings, you are ready to print. If you have any trouble while printing, see Chapter 7, "Troubleshooting," for solutions.

For DOS Program Users

Installing a printer driver for DOS applications

To install a printer driver in most DOS applications, you must select the printer you are using during the installation or setup procedure.

Choose the EPSON LQ-670 printer at the appropriate step in the procedure. If the list in your application does not include the LQ-670 printer, choose the first available printer from this list:

LQ-2070
LQ-2170
LQ-870/ 1170
LQ-570/ 1070/ 570+/ 1070+
DLQ-3000
DLQ-2000
LQ-1060
LQ-1050
LQ-2550
LQ-2500

If none of these printers is listed, choose the first one available from the following:

LQ
EX
FX
LX
RX
MX
EPSON printer
Standard printer
Draft printer

Note:

If your application does not list a suitable alternative, contact the software manufacturer to see if an update is available.

Using the EPSON Remote! printer utility

The EPSON Remote! utility is included with the printer. This utility allows you to change the printer's default settings from your computer.

Installing the printer utility

Follow the steps below to install the EPSON Remote! utility.

1. Insert the printer driver disk in a disk drive.
2. At the DOS prompt, type `A:\ SETUP` (or `B:\ SETUP`) and press **Enter**.
3. At the next screen, select your printer and press **Enter**. The default directory `C:\ EPUTIL` appears.
4. Press **Enter**. The printer utility is copied into the EPUTIL directory on drive C.

Accessing the printer utility

When you want to access the EPSON Remote! utility, follow these steps:

1. Change the current directory to drive C.
2. Type `PRNSET`, and press **Enter**. Follow the on-screen instructions to use the utility.

Chapter 3

Paper Handling

Selecting a Paper-Feeding Method	3-2
Paper-feeding methods and paper types	3-3
Setting the paper release lever	3-4
Adjusting the Paper Thickness Lever	3-5
Using Single Sheets	3-6
Using Continuous Paper	3-9
Positioning your continuous paper supply	3-10
Loading continuous paper with the tractor	3-11
Using the tear-off function	3-16
Removing continuous paper	3-20
Using Multi-part Forms	3-20
Using Labels	3-21
Using Envelopes	3-23
Using Postcards	3-24
Switching Between Continuous Paper and Single Sheets	3-25
Switching to single sheets	3-25
Switching to continuous paper	3-26
Using Micro Adjust	3-27
Adjusting the loading position	3-27
Adjusting the printing position	3-29
Adjusting the tear-off position	3-31



Your printer can print on a wide variety of paper types, including single sheets, continuous paper, multi-part forms, labels, envelopes, postcards, and roll paper. This chapter explains how to use these paper types with your printer.

Note:

See Appendix A for detailed specifications on the paper types the printer can use.

Selecting a Paper-Feeding Method

Your printer can accommodate a variety of paper types through four paper-feeding methods: paper guide, tractor, optional cut-sheet feeder, or optional roll paper holder. The paper-feeding method you select depends on the type of paper you want to use.

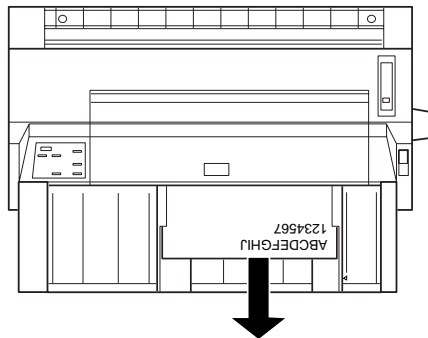

For all four paper-feeding methods, the printer prints on the paper and then ejects it as shown below.







Note:

When using any type of paper, make sure you load it printable side up.

Paper-feeding methods and paper types

The table below shows which paper-feeding method to select for each paper type. You use the paper release lever to select the paper-feeding method:  for tractor feeding or  for single-sheet feeding, as described in the next section.

Paper type	Paper-feeding method			
	Tractor 	Paper guide 	Optional cut-sheet feeder 	Optional roll paper holder** 
Single sheets	–	○	○	–
Continuous paper	○	–	–	–
Single-sheet multi-part forms	–	○	○* (bin 1 only)	–
Continuous multi-part forms	○	–	–	–
Labels	○	–	–	–
Envelopes	–	○	○ (bin 1 only)	–
Postcards	–	○	○ (bin 1 only)	–
Roll paper	–	–	–	○



○ : You can use this paper type with this paper-feeding method.

– : You cannot use this paper type with this paper-feeding method.

* You can use only single-sheet multi-part forms that are glued at the top of the forms.

** The optional roll paper holder is available only in some countries.

Setting the paper release lever

You use the paper release lever to set the paper path you want the printer to use. The paper release lever has two positions:  for tractor feeding and  for single-sheet feeding, as explained below.

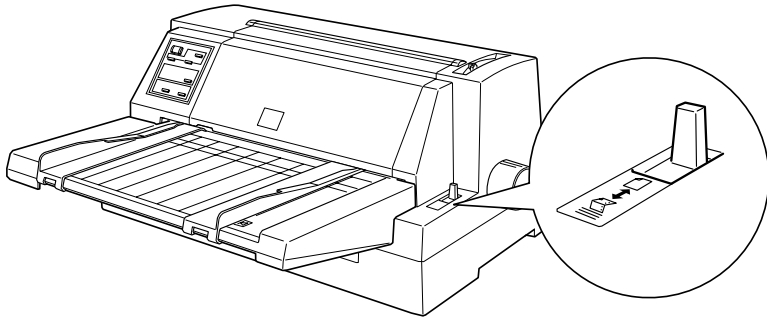

Single-sheet feeding position – for loading single sheets (including envelopes and postcards) from the paper guide, the optional cut-sheet feeder, or the optional roll paper holder.



Tractor feeding position – for loading continuous paper from the tractor.

Adjusting the Paper Thickness Lever

You need to set the paper thickness lever to match the thickness of your paper. When you print on ordinary single-sheet or continuous paper, set the lever to the “0” position on the scale as shown below.

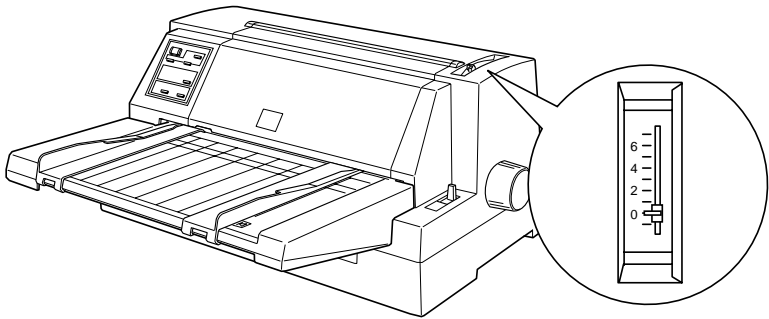

The following table provides guidelines for selecting the appropriate lever position for the type of paper you are using.

Paper type	Paper thickness lever position
Thin paper	0 or 1
Ordinary paper (single sheets or continuous paper)	0
Multi-part forms (carbonless) 2 parts (original plus + 1 copy)	1
3 parts (original plus + 2 copies)	2
4 parts (original plus + 3 copies)	3
5 parts (original plus + 4 copies)	5
Labels and postcards	2
Envelopes*	2 to 6

* For thin envelopes, such as airmail envelopes, select position 2 or 3; for regular envelopes, select position 4; for thick envelopes, select position 4, 5, or 6.



Caution:

A always set the paper thickness lever back to the “0” position before you print on ordinary paper again.

Using Single Sheets

Your printer can print on single sheets of paper from 92 to 297 mm (3.6 to 11.7 inches) wide. See Appendix A for detailed single-sheet paper specifications.

You can load one sheet of paper at a time into the paper guide at the front of the printer, or you can load a stack of paper in the optional cut-sheet feeder. (See Chapter 5 for more information on the optional cut-sheet feeder.)

Note:

If you load long paper (for example, legal size paper), leave enough space at the back of the printer so that the paper is not obstructed.

Follow these steps to load single sheets:

1. Make sure that the printer is off and the paper guide is attached as described in Chapter 1. Then close the sprocket covers and push down the sprocket lock levers to lock the sprocket units in place.

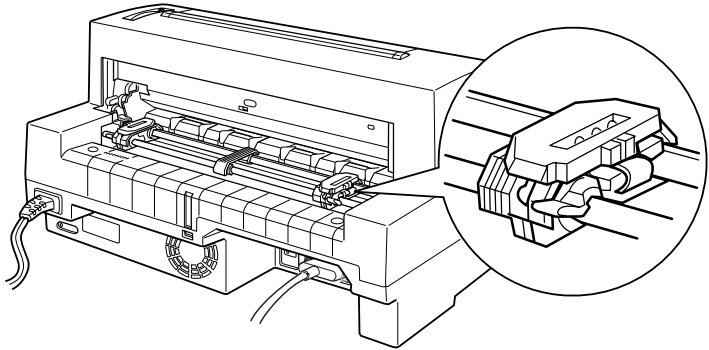

2. Set the paper release lever to the single-sheet position as shown below. Also make sure the paper thickness lever is set to “0” if you are using ordinary single-sheet paper.

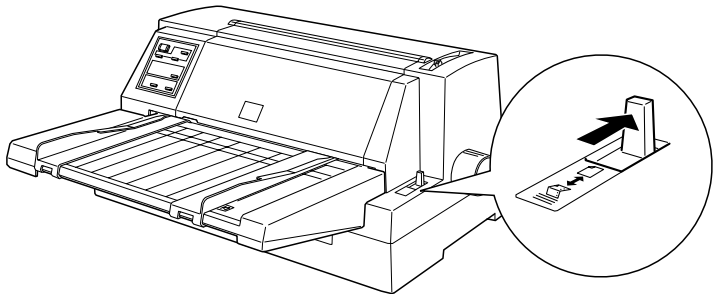

3. Press the **Operate** button to turn on the printer.

- Slide the right edge guide until it rests against the guide mark, as shown below.

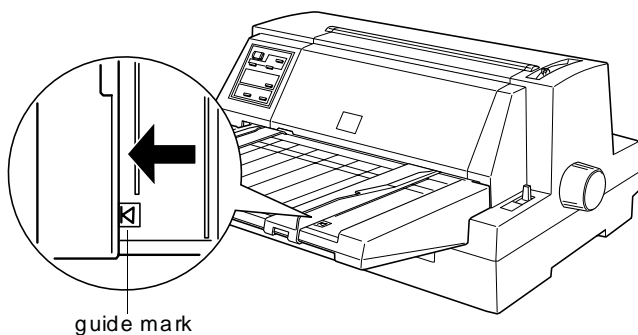

- While adjusting the left edge guide to match the width of your paper, insert a sheet of paper between the edge guides until it meets resistance. Be sure to load your paper printable side up.

After a few seconds, the printer automatically advances the paper to the loading position. The printer is ready to accept data from your computer and print.

Note:

If the platen rotates but the printer does not load the paper, completely remove the paper and then insert it all the way into the printer again. If you need to adjust the position of the paper after it is loaded, see "Adjusting the loading position" on page 3-27.

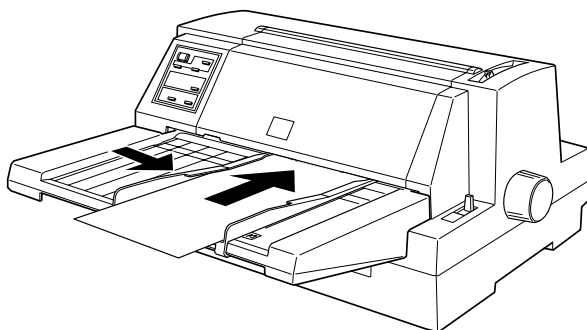

After printing a sheet, the printer ejects the printed sheet onto the paper guide and the **Paper Out** and **Pause** lights come on. If you are printing a multiple-page document, remove the printed sheet and insert a new sheet into the paper guide. The printer automatically advances the paper and resumes printing.

Note:

*If the printer does not eject the printed sheet, press the **Load/Eject** button.*



Caution:

Use the knob on the right side of the printer only to clear paper jams when the printer is off. Otherwise, you may damage the printer or cause it to lose the top-of-form position.

Using Continuous Paper

Your printer can print on continuous paper from 101 to 304.8 mm (4.0 to 12.0 inches) wide. You can load continuous paper from the built-in tractor unit.

Note:

See Appendix A for detailed specifications on continuous paper.

Positioning your continuous paper supply

When you load continuous paper, make sure you align your paper supply with the tractor so the paper feeds smoothly into the printer, as shown below.

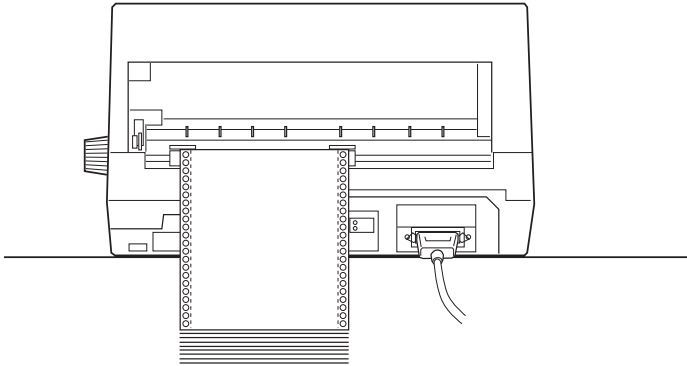
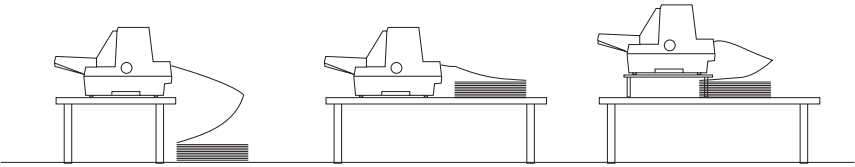

Loading continuous paper with the tractor

1. Make sure the printer is turned off. Set the paper release lever to the tractor position, as shown below. Also make sure the paper thickness lever is set to “0” if you are using ordinary continuous paper.

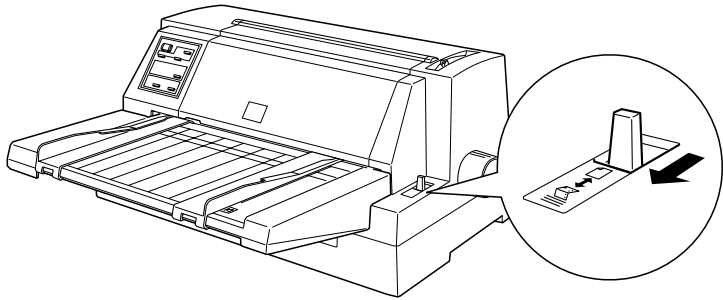

2. Slide the edge guides as far apart as they go.

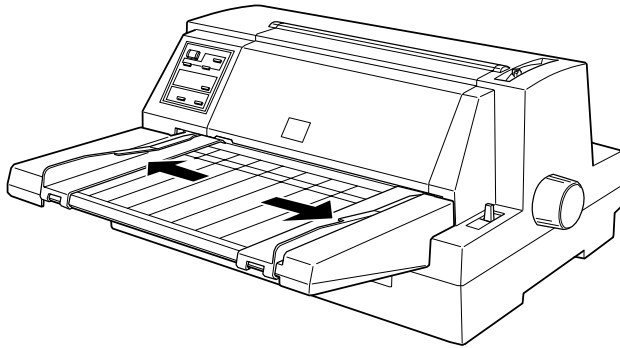

3. Release the sprocket lock levers by pushing them up.

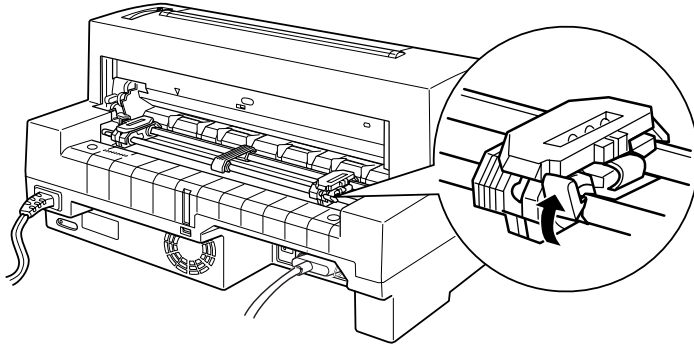

4. Facing the back of the printer, position the left sprocket unit so that the sprocket pins are to the left of the “0” on the scale and the arrow mark on the printer. Then push down the lock lever to lock the sprocket in place.

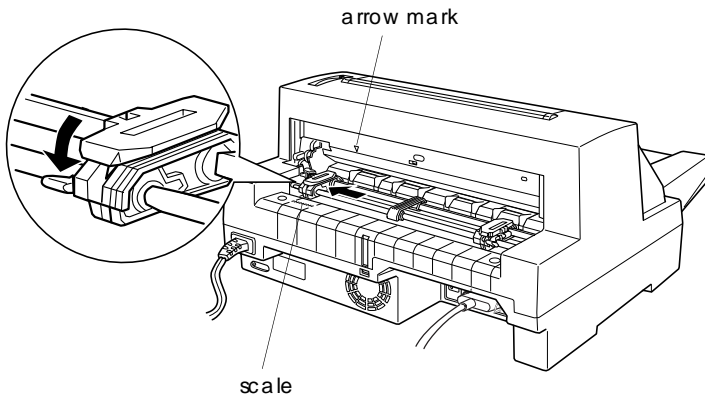

Note:

Printing starts at the arrow mark on the printer and the “0” mark on the scale. The unprintable area is to the left of the arrow mark and the “0”.

5. Slide the right sprocket unit to roughly match the width of your paper, but do not lock it.

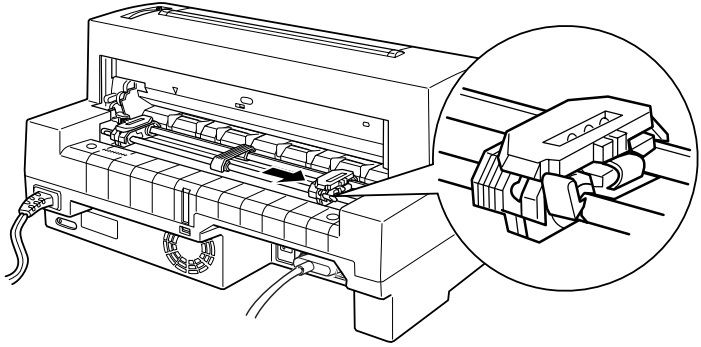

3

6. Slide the paper support midway between the two sprocket units.

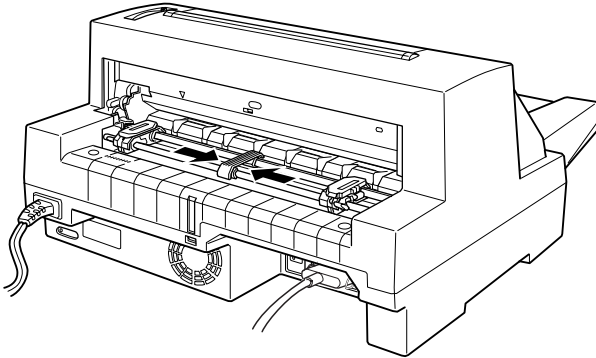

7. Open the sprocket covers.

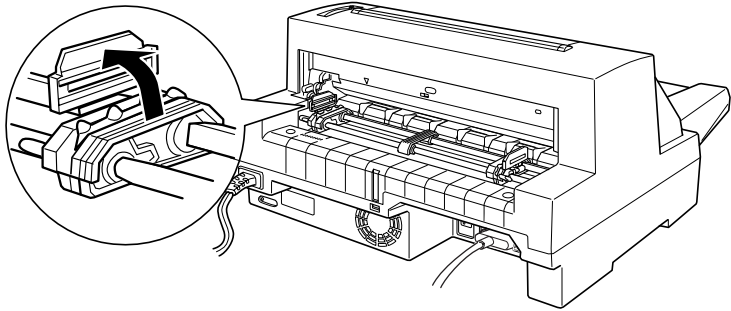

8. Fit the first three holes of the continuous paper over the sprocket pins on both sides. Be sure to load your paper printable side up.

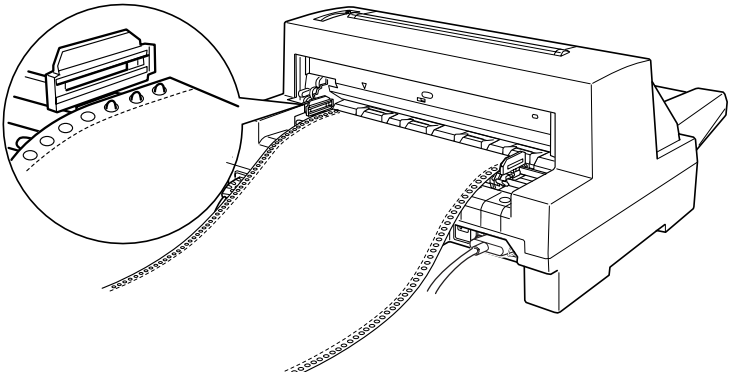

Caution:

Make sure the first sheet of your continuous paper has a clean, straight edge so that it can feed smoothly into the printer.

9. Close the sprocket covers. If necessary, unlock and reposition the left sprocket unit so that the perforation aligns with the arrow mark on the printer. Then lock the sprocket in place.

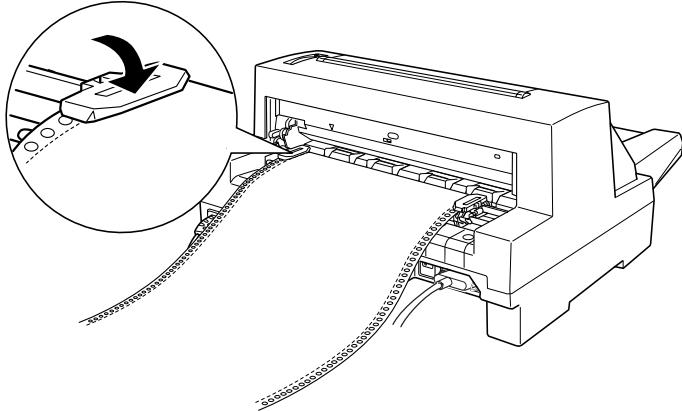

10. Slide the right sprocket unit to remove any slack in the paper. Then push down the sprocket lock lever to lock the sprocket in place.

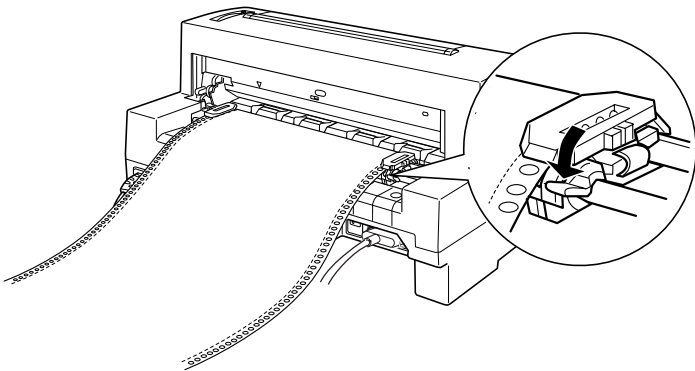

11. Press the **Operate** button to turn on the printer. When the printer receives data, it automatically loads the paper before printing.

When using continuous paper, you can use the tear-off function to tear off printed pages and save the blank pages that are usually wasted between print jobs. For more information, see the next section.

Note:

- You can advance the paper to the loading position by pressing the **Load/Eject** button.*
- Always make sure there is at least one more sheet than required, because continuous paper may not feed properly if it is not fed through the sprocket.*



Caution:

Use the knob on the right side of the printer only to clear paper jams when the printer is off. Otherwise, you may damage the printer or cause it to lose the top-of-form position.

Using the tear-off function

After you have finished printing, you can use the tear-off function to advance continuous paper on the tractor to the tear-off edge of the printer. You can then easily tear off printed sheets. When you resume printing, the printer automatically feeds paper back to the loading position so you can save paper that would normally be lost between documents.

You can use the tear-off function in two ways: by pressing the **Tear Off/Bin** button on the control panel, or by using the control panel's default-setting mode or the EPSON Remote! utility to select auto tear-off. (See page 4-9 for information on the printer's default-setting mode.)

If the perforation between pages is not aligned with the tear-off edge, you can adjust the tear-off position using the micro-adjust feature as described later in this chapter.



Caution:

Never use the tear-off function to feed labels backwards; they may come off their backing and jam the printer.

Using the Tear Off/ Bin button

When using the tractor, you can use the **Tear Off/ Bin** button to advance continuous paper to the tear-off position by following the steps below:

1. Make sure printing has finished. Then press the **Tear Off/ Bin** button until the two lights on the control panel start flashing. The printer advances the paper to the tear-off edge.

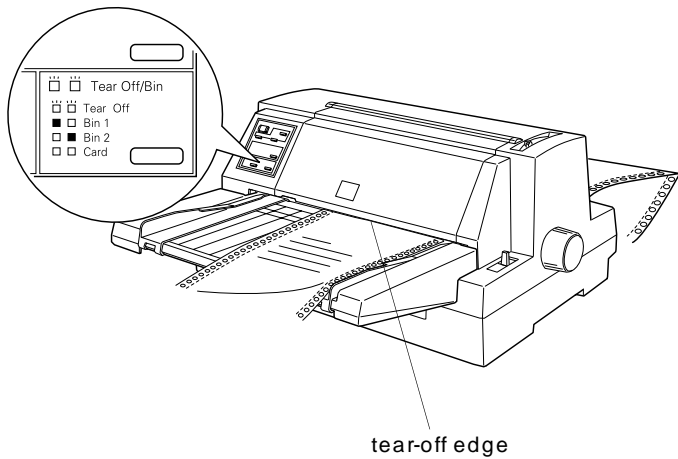

2. Tear off all printed pages. If the perforation is not aligned with the tear-off edge, adjust the tear-off position using the micro-adjust feature. See “Adjusting the tear-off position” later in this chapter.

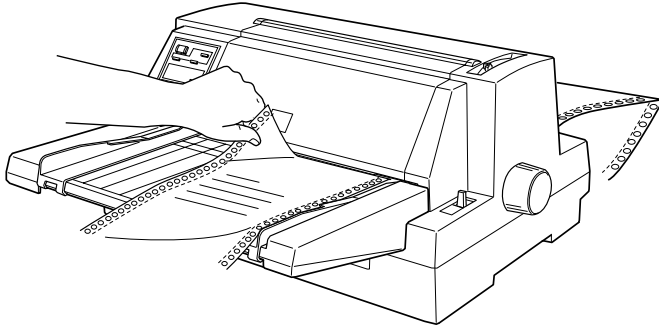

3. When you resume printing, the printer feeds the paper back to the top-of-form position and begins printing. (You can also manually feed the paper back to the top-of-form position by pressing the **Tear Off/Bin** button.)

Using auto tear-off mode

When you turn on the auto tear-off function in the printer’s default-setting mode or the EPSON Remote! utility, the printer advances continuous paper to the tear-off position when you finish printing.

The printer advances paper to the tear-off position only when it receives a full page of data or a form-feed command and then receives no more data for three seconds.

For instructions on how to activate the auto tear-off function, see “Using the Default-Setting Mode” in Chapter 4 or open the EPSON Remote! utility as described in Chapter 2 and follow the on-screen instructions. While using the default-setting mode or the utility, also make sure the page length is set correctly for your continuous paper. If you make these settings in the default-setting mode, be sure to turn off the printer then turn it on again to apply your settings.

The steps below describe how to use auto tear-off.

1. When you finish printing on continuous paper, the printer advances the perforation of the final printed page to the tear-off position.
2. Tear off all printed pages. (If the perforation is not aligned with the tear-off edge, you can adjust the tear-off position using the micro-adjust feature. See “Adjusting the tear-off position” later in this chapter.)
3. When you resume printing, the printer automatically feeds the paper back to the top-of-form position and begins printing. (You can also manually feed the paper back to the top-of-form position by pressing the **Tear Off/Bin** button.)

You can leave auto tear-off mode on even when you are using single sheets because the mode is disabled when you move the paper release lever to the single-sheet position.

Removing continuous paper

1. After you finish printing, press the **Tear Off/Bin** button. The printer advances the paper to the tear-off position.

Note:

When the auto tear-off function is on, the printer advances the paper perforation to the tear-off position automatically. You can turn on the auto tear-off function by using the printer's default-setting mode or the EPSON Remote! utility. For instructions, see "Using the Default-Setting Mode" in Chapter 4, or open EPSON Remote! as described in Chapter 2 and follow the on-screen instructions.

2. Tear off the printed pages.
3. Press the **Load/Eject** button to feed the continuous paper backward out of the printer and into the standby position.
4. To completely remove continuous paper from the printer, open the sprocket covers. Remove the paper from the tractor unit, and then close the sprocket covers.

Using Multi-part Forms

Your printer can print on both single-sheet and continuous multi-part forms. It can use multi-part forms with up to five parts including the original.



Caution:

Use only carbonless multi-part forms.

Before printing, set the paper thickness lever to the correct position for your multi-part forms as described in the table on page 3-6.

You can load single-sheet multi-part forms from the paper guide or with the optional cut-sheet feeder. For instructions, see “Using Single Sheets” on page 3-6 or “Loading paper from the cut-sheet feeder” in Chapter 5. You can load continuous multi-part forms in the same way as you load ordinary continuous paper. For instructions, see “Using Continuous Paper” earlier in this chapter.



Caution:

- ❑ *When printing on multi-part forms, make sure that your software settings keep the printing entirely within the printable area of the forms. Printing on the edge of a multi-part form can damage the print head. For information about the printable area, see the paper specifications in Appendix A.*
- ❑ *Load single-sheet multi-part forms glued at the side of the form only from the paper guide, not from the optional cut-sheet feeder.*

Using Labels

When selecting labels for printing, always choose labels mounted on continuous backing sheets with sprocket holes for use with a tractor. Do not use labels on shiny single-sheet backing, because the backing sheet tends to slip and may not feed properly.

You load labels in the same way as you load continuous paper, except that you set the paper thickness lever to “2.” For instructions on loading continuous paper, see “Using Continuous Paper” earlier in this chapter.



Caution:

- ❑ *When printing on labels, make sure that your software settings keep the printing entirely within the printable area. Printing on the edge of a label can damage the print head. For information about the printable area, see the paper specifications in Appendix A.*
- ❑ *Because labels are especially sensitive to temperature and humidity, use them only under normal operating conditions.*
- ❑ *Do not leave labels loaded in the printer between print jobs; they tend to curl and may come off their backing and jam the printer when you resume printing.*
- ❑ *Never feed labels backward with the **Load/Eject** or **Tear Off/Bin** buttons. Labels can easily peel off their backing and jam the printer.*
- ❑ *To remove labels from the paper path after you finish printing, first tear off the labels at a point before the paper slot. Then use the **LF/FF** button to advance the remaining labels out of the printer.*

Using Envelopes

You can print on a variety of envelopes, loading them in the same way as you load single sheets: from the paper guide or with the optional cut-sheet feeder. For information on loading envelopes, read this section and see “Using Single Sheets” earlier in this chapter or “Loading paper from the cut-sheet feeder” in Chapter 5.

Before printing, set the paper thickness lever to the correct position for your envelopes as described in the table on page 3-6.

Load envelopes face up, long edge first. Make sure that the right edge guide is aligned with the arrow on the paper guide, and position the left edge guide to match the width of your envelope.

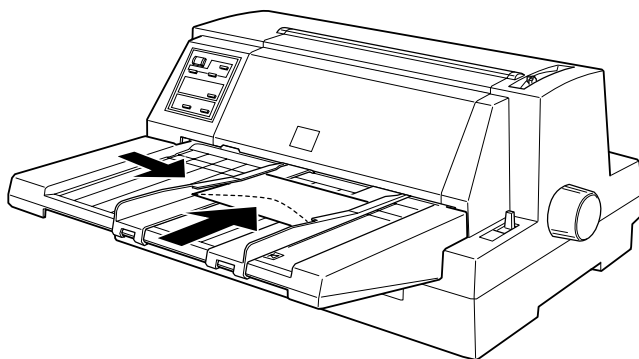

Caution:

- ❑ *When printing on envelopes, make sure that your software settings keep the printing entirely within the printable area. Printing on the edge of an envelope can damage the print head. For information about the printable area, see the paper specifications in Appendix A.*

- ❑ *Use envelopes only under normal operating conditions.*

Using Postcards

You can print on a variety of postcards, loading them in the same way as you load single sheets: from the paper guide or with the optional cut-sheet feeder. (For instructions on loading single sheets, read this section and see “Using Single Sheets” on page 3-6 or “Loading paper from the cut-sheet feeder” in Chapter 5.)

Before printing, set the paper thickness lever to “2.” Then select Card mode by pressing the **Tear Off/Bin** button until both **Tear Off/Bin** lights are on.

Load postcards printable side up. Make sure that the right edge guide is aligned with the arrow on the paper guide, and position the left edge guide to match the width of your postcard.

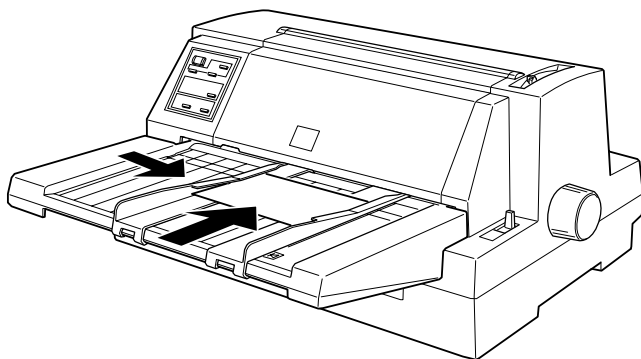

Caution:

- Card mode is available only when the paper thickness lever is set to “2” or higher on the scale.*
- When printing on postcards, make sure that your software settings keep the printing entirely within the printable area. Printing on the edge of a postcard can damage the print head. For information about the printable area, see the paper specifications in Appendix A.*
- Use postcards only under normal operating conditions.*

Switching Between Continuous Paper and Single Sheets

When using the tractor, you can easily switch between continuous paper and single sheets (including envelopes or postcards) without removing the continuous paper from the tractor.

Switching to single sheets

To switch from continuous paper to single sheets, follow the steps below.

1. When you have finished printing on continuous paper, press the **Tear Off/Bin** button to advance the paper to the tear-off position. (If you selected auto tear-off in the printer's default-setting mode or the EPSON Remote! utility, the printer advances the paper perforation to the tear-off position automatically.)
2. Tear off the printed pages.



Caution:

- Always tear off paper before feeding it backwards; feeding too many sheets backwards can cause a paper jam.*
 - Never feed labels backward with the **Load/Eject** or **Tear Off/Bin** buttons. Labels can easily peel off their backing and jam the printer. For information on removing labels from the paper path, see page 3-22.*
3. Press the **Load/Eject** button to feed the continuous paper back to the standby position. The paper is still attached to the tractor, but no longer in the paper path.

4. Move the paper release lever back to the single-sheet position.

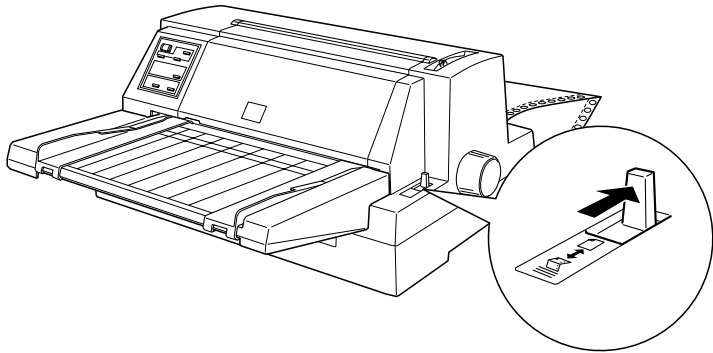

Now you can load single sheets from the paper guide. For instructions, see “Using Single Sheets” on page 3-6.

Switching to continuous paper

To switch from single sheets to continuous paper, follow the steps below.

1. If necessary, press the **Load/Eject** button to eject the last printed single sheet.
2. Make sure continuous paper is loaded in the printer as described under “Loading continuous paper with the tractor” on page 3-11.

3. Move the paper release lever forward to the tractor position.

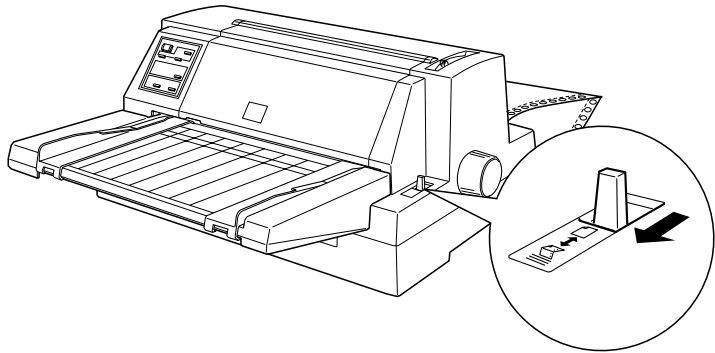

The printer automatically advances the continuous paper from the standby position to the loading position when it receives data.

Using Micro Adjust

The micro-adjust feature allows you to move paper forward or backward in 1/180-inch increments. You can use this feature to adjust the loading, printing, and tear-off positions.

Adjusting the loading position

The loading position is the position of the paper after the printer loads it automatically. If your printing appears too high or low on the page, you can change the loading position with the micro-adjust feature as follows:

Note:

Top margin settings made in some application software override adjustments you make to the loading position with the micro adjust feature. If necessary, adjust the loading position in your software.

1. Make sure the printer is turned on. If necessary, lift up the printer cover so you can see the paper position.
2. Load either continuous or single-sheet paper. (Press the **Load/Eject** button to load continuous paper or a single-sheet from the optional cut-sheet feeder.)
3. Hold down the **Pause** button for about three seconds. The **Pause** light starts flashing and the printer enters the micro-adjust mode.
4. Press the **LF/FF** [**↓**] button to move the loading position down on the page, or press the **Load/Eject** [**↑**] button to move the loading position up on the page.

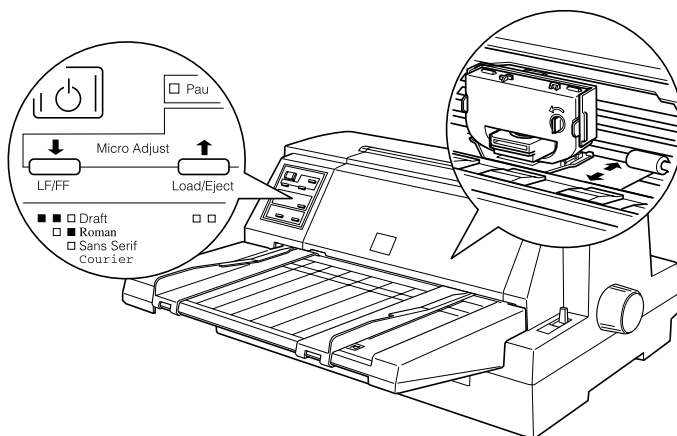

Note:

- ❑ *The printer has a minimum and a maximum loading position. If you try to adjust the loading position beyond these limits, the printer beeps and stops moving the paper.*
- ❑ *When the paper reaches the factory-set loading position, the printer beeps and paper feeding pauses briefly. Use the factory setting as a reference point when adjusting the loading position.*

- *If you want to eliminate the top margin and print at the very top of the page, adjust the loading position so that the top of the paper lines up with the raised line on the ribbon mask, as shown below.*

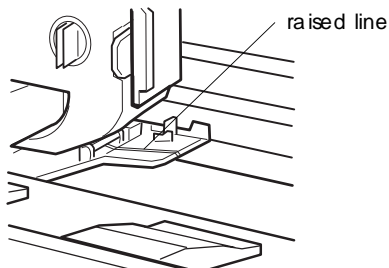

5. After you set the loading position, press the **Pause** button to turn off micro-adjust mode.

For both single-sheet and continuous paper, your loading position setting remains in effect until you change it, even if you turn off the printer.

Adjusting the printing position

The printing position is the position on the page where the print head actually prints during a print job. You can change the current vertical printing position temporarily by using the micro-adjust feature as described in the steps below.

Note:

Your printing position setting is in effect only until the next time you load paper or turn off the printer.

1. Make sure that the printer is not printing. If it is, press the **Pause** button to stop printing.

2. Hold down the **Pause** button for about three seconds. The **Pause** light begins flashing and the printer enters the micro-adjust mode.
3. If necessary, open the printer cover to check the printing position, and press the **LF/FF** [↓] button to feed paper forward or the **Load/Eject** [↑] button to feed paper backward.

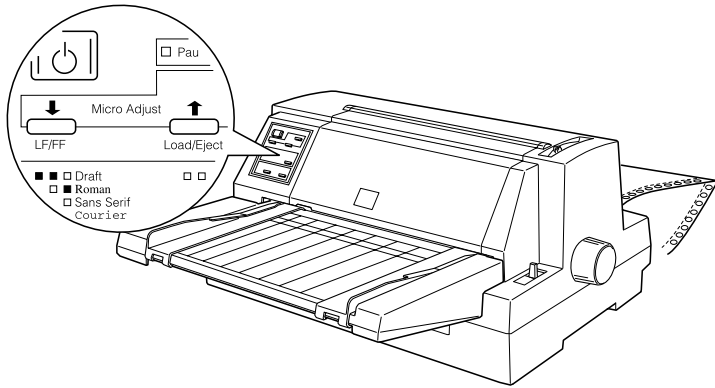

4. When your paper is positioned correctly, press the **Pause** button to turn off micro-adjust mode and resume printing.

Adjusting the tear-off position

If your paper perforation is not aligned with the tear-off edge, you can use the micro-adjust feature to move the perforation to the tear-off position as follows:

1. Make sure both **Tear Off/Bin** lights are flashing (the paper is at the current tear-off position). You may need to press the **Tear Off/Bin** button.

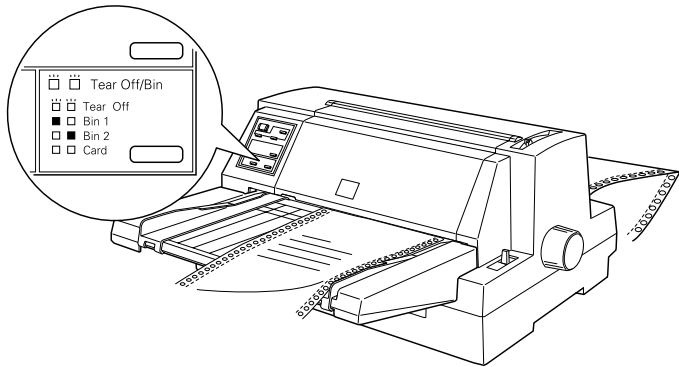

2. Hold down the **Pause** button for about three seconds. The **Pause** light begins flashing and the printer enters the micro-adjust mode.

3. Press the **LF/FF** [↓] button to feed paper forward, or press the **Load/Eject** [↑] button to feed paper backward, until the paper perforation is aligned with the tear-off edge.

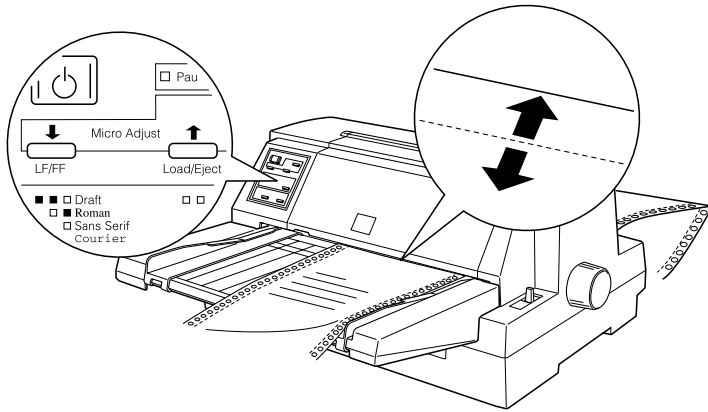

Note:

The printer has a minimum and a maximum tear-off position. If you try to adjust the tear-off position beyond these limits, the printer beeps and stops moving the paper.

4. Tear off the printed pages.
5. Press the **Pause** button to turn off micro-adjust mode.

When you resume printing, the printer automatically feeds the paper back to the top-of-form position and begins printing. Your tear-off position setting remains in effect until you change it, even if you turn off the printer.

Chapter 4

Using the Control Panel

Basic Control Panel Functions	4-2
Lights	4-3
Buttons	4-4
Advanced Control Panel Functions	4-7
Using the Default-Setting Mode	4-9
Default-setting mode options	4-9
Changing the default settings	4-14
Using Quiet Mode	4-16



This chapter explains how you can use the control panel to control the basic operation of the printer and to perform more advanced operations, such as making changes to default settings or activating the printer's quiet mode.

Basic Control Panel Functions

The indicator lights on the control panel let you monitor the current status of the printer, and the buttons let you control many printer operations.

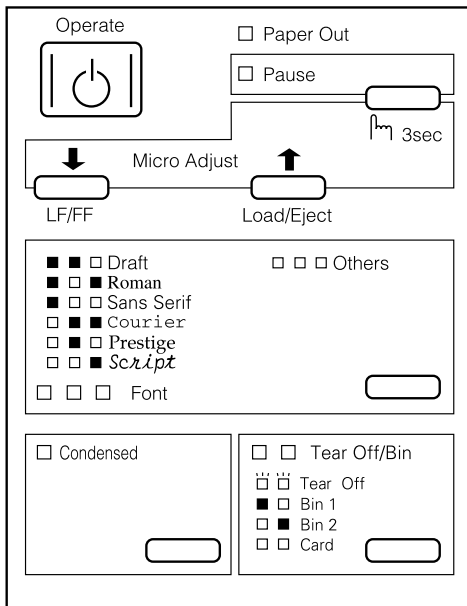

Lights

Paper Out (red)

On when the printer runs out of paper. Flashes when the paper is jammed.

Pause (orange)

On when the printer is not ready to print data, paper is out or jammed, or you press the **Pause** button to pause printing. Flashes when the printer is in micro-adjust mode or the print head is too hot.

Font (three lights, green)

The printer uses the three **Font** lights to indicate the selected font as follows:

■ ■ □	Draft
■ □ ■	Roman
■ □ □	Sans Serif
□ ■ ■	Courier
□ ■ □	Prestige
□ □ ■	Script
□ □ □	Others*

□ = On, ■ = Off

* This light pattern means that a font other than those indicated on the control panel has been selected using the default-setting mode or the EPSON Remote! utility. (The fonts available in the default-setting mode or EPSON Remote! are: OCR-B, Orator, Orator-S, Script C, Roman T, or Sans Serif H.)

Condensed (green)

On when you press the **Condensed** button to print condensed characters.

Tear Off/Bin (two lights, green)

The printer uses the two **Tear Off/Bin** lights to indicate the following:

- | | |
|--------------------------------------------------------------|-------------------------------------------------------------------------------------------|
| <input type="checkbox"/> <input type="checkbox"/> | The perforation of your continuous paper is at the tear-off position. |
| <input checked="" type="checkbox"/> <input type="checkbox"/> | The optional high-capacity cut-sheet feeder (bin 1 of the double-bin feeder) is selected. |
| <input type="checkbox"/> <input checked="" type="checkbox"/> | The optional second-bin cut-sheet feeder (bin 2 of the double-bin feeder) is selected. |
| <input type="checkbox"/> <input type="checkbox"/> | Card mode is selected (for printing on postcards). |

= Flashing, = On, = Off

Buttons

Operate

Press this button to turn the printer on or off.

Pause

Press this button to temporarily stop printing, and press it again to resume printing. To turn on the micro-adjust mode, stop printing and hold down this button for at least 3 seconds. Press it again to turn off the micro-adjust mode. See “Using Micro Adjust” in Chapter 3 for details.

Load/Eject

Press this button to advance single-sheet or continuous paper to the loading position. (The printer normally loads paper automatically.) If a single sheet is already in the loading position, press this button to eject it. If continuous paper is in the loading or tear-off position, press this button to feed it backward to the standby position.

LF/FF (line feed/ form feed)

Press this button briefly to feed the paper forward one line. Hold it down to eject a single sheet or advance continuous paper to the top of the next page. You can also use this button to load a single sheet of paper from the optional cut-sheet feeder or to feed continuous paper from the standby position to the loading position.

Font

Press this button to select one of the following fonts: Draft, Roman, Sans Serif, Courier, Prestige, Script, or Others. Others means a font other than those indicated on the control panel has been selected using the default-setting mode or the EPSON Remote! utility.

Printing with the Draft font requires fewer dots per character, which significantly increases the printing speed. However, printing with this font also reduces print quality. When you need letter-quality printing, select a font other than Draft.

Font	Sample
Draft	
Roman	
Sans Serif	
Courier	
Prestige	
Script	
OCR-B*	
Orator*	
Orator-S*	
Script C*	
Roman T*	
Sans Serif H*	

* If one of these fonts is selected, all three Font lights on the control panel are on to indicate that the current font was set in the default-setting mode or the EPSON Remote! utility.

Note:

The typestyle samples on the control panel are meant as guides only; printed results may differ slightly.

Condensed

Press this button to print condensed characters. Press it again to return to printing normal characters.

Tear Off/Bin

Press this button to move continuous paper to the tear-off position. Press it again to move the next page to the top-of-form position.

When the optional cut-sheet feeder is installed, press this button to select the cut-sheet feeder bin you want to use. Select **Bin 1** to use the high-capacity cut-sheet feeder, and select **Bin 1** or **Bin 2** to use the double-bin cut-sheet feeder.

To print on postcards, select **Card** mode by pressing this button until both **Tear Off/Bin** lights are on. (Card mode is available only when the paper thickness lever is set to “2” or higher on the scale.)

Note:

*Paper source settings (such as bin 1 or bin 2) made in your software override bin settings made with the **Tear Off/Bin** button, so use your software to make this setting whenever you can.*

Advanced Control Panel Functions

Besides giving you control of the basic operation of the printer, the control panel allows you to enter the printer’s default-setting and quiet modes, and to access several features helpful when troubleshooting.

To use the functions below (in italics), turn on the printer while pressing the corresponding control panel button(s).

Letter-quality self test = Load/Eject

Performs a letter-quality self test, which helps you determine the source of some printing problems. See “Printing a Self Test” in Chapter 7 for details.

Draft self test = LF/FF

Performs a draft self test, which helps you determine the source of some printing problems. See “Printing a Self Test” in Chapter 7 for details.

Bidirectional adjustment = Pause

Turns on the bidirectional adjustment mode, which allows you to correct printing alignment problems. See “Using Bidirectional Adjustment” in Chapter 7 for details.

Hex dump = Load/Eject + LF/FF

Prints the data sent to the printer in hexadecimal code, which helps experienced users determine the source of some printing problems. See “Using Hex Dump Mode” in Chapter 7 for details.

Default setting = Font

Turns on the default-setting mode, which allows you to change the printer’s default settings. For more information, see “Using the Default-Setting Mode” later in this chapter.

Quiet mode = Font + Condensed

Turns on the printer’s quiet mode, which lowers the noise level during printing. For more information, see “Using Quiet Mode” later in this chapter.

Using the Default-Setting Mode

The default settings control many printer functions. While you can often set these functions through your software or printer driver, you may sometimes need to change a default setting from the printer's control panel using the default-setting mode.

For a detailed description of the settings you can change in the default-settings mode, see the next section. For instructions on changing the settings, see "Changing the default settings" later in this chapter.

Default-setting mode options

This section describes the options and settings available in the default-setting mode. Use the table below for quick reference when changing default settings. The options are explained in more detail after the table.

Option	Settings
Page length for tractor	3, 3.5, 4, 5.5, 6, 7, 8, 8.5, 11, 70/6, 12, 14, 17 inches
Skip-over-perforation	On, Off
Auto tear off	On, Off
Auto line feed	On, Off
Print direction	Auto, Bi-d, Uni-d
I/F (interface) mode	Auto, Parallel I/F, Option I/F
Auto I/F (interface) wait time	10 seconds, 30 seconds
Software	ESC/P 2, IBM 2390 Plus

Option	Settings
Character table	Standard model: Italic, PC437, PC850, PC860, PC863, PC865, PC861, BRASCII, Abicomp, ISO Latin 1, Roman 8 All other models: Italic, PC437, PC437 Greek, PC850, PC852, PC853, PC855, PC857, PC864, PC866, PC869, ISO Latin 1T, ISO 8859-7, MAZOWIA, Code MJK, Bulgaria, Estonia, PC774, ISO 8859-2, PC866 LAT.
International character set for italic table	Italic U.S.A., Italic France, Italic Germany, Italic U.K., Italic Denmark, Italic Sweden, Italic Italy, Italic Spain
0 slash	On, Off
High speed draft	On, Off
Input buffer	On, Off
Buzzer	On, Off
Auto CR (IBM 2390 Plus) **	On, Off
AGM (IBM 2390 Plus) **	On, Off
Font *	OCR-B, Orator, Orator-S, Script C, Roman T, Sans Serif H

* Fonts selected in the default setting mode correspond to Others on the control panel. The following additional fonts are available only by pressing the Font button on the control panel: Draft, Roman, Sans Serif, Courier, Prestige, and Script.

** These settings are effective only when IBM 2390 Plus emulation is selected.

Page length for tractor

For paper fed through the tractor, you can set the page length to one of the following: 3, 3.5, 4, 5.5, 6, 7, 8, 8.5, 11, 70/ 6, 12, 14, or 17 inches.

Skip-over-perforation

This feature is available only when continuous paper is selected. When you turn on this feature, the printer provides a one-inch (25.4 mm) margin between the last line printed on one page and the first line printed on the next page. Because most application programs set their own top and bottom margins, you should use this feature only if you cannot set your top and bottom margins using your application.

Auto tear-off

When auto tear-off is on and you are using continuous paper with the tractor, the printer automatically advances the paper perforation to the tear-off position, where you can easily tear off the printed page(s). When the printer receives data again, it automatically moves the paper back to the top-of-form position and starts printing, so you can use all of the next page.

When auto tear-off is turned off, you need to move the perforation to the tear-off position manually by pressing the **Tear Off/Bin** button. See “Using the tear-off function” in Chapter 3 for more information.

Auto line feed

When auto line feed is on, the printer accompanies each carriage return (CR) code received with a line feed (LF) code.

Print direction

You can select auto print direction, bidirectional printing (Bi-d), or unidirectional printing (Uni-d). Printing is normally bidirectional; however, unidirectional printing allows for precise vertical printing alignment.

I/F(interface) mode

The printer has space for one optional interface in addition to its built-in parallel interface. You can choose automatic, parallel, or optional for the interface mode. When you select auto, the printer automatically selects the interface that is receiving data, and uses that interface until the end of the print job. This auto interface allows you to share the printer among multiple computers without making changes.

When you connect one computer to the printer, you can select the parallel or optional interface according to the interface your computer requires.

Auto I/F(interface) wait time

The printer determines which interface is receiving data and switches to that interface until the end of the print job (when no data is received from the selected interface for the amount of time specified). You can specify either 10 seconds or 30 seconds.

Software

When you select ESC/ P 2, the printer operates in the EPSON ESC/ P 2 mode. When you select IBM the printer emulates an IBM printer.

Character table

Your printer has 11 standard character tables as well as tables for 20 other countries. See Appendix B for character samples.

International character set for Italic table

You can change eight characters in the Italic character table to suit your printing needs. Since these characters are often used in other languages, they are named after countries and are referred to as international character sets. See Appendix B for character samples.

0 slash

The zero character has a slash (0) when this feature is on; it has no slash (0) when this feature is off. The slash allows you to easily distinguish between an uppercase letter “O” and a zero.

High speed draft

In high speed draft mode, the printer prints up to 300 cps (characters per second) at 10 cpi (characters per inch) when the Draft font is selected. If you select normal speed draft, it prints up to 250 cps at 10 cpi when Draft is selected.

Input buffer

The input buffer stores data sent from your computer. The input buffer can store up to 64KB of data, so you can free your computer for other tasks while the printer prints. When the buffer is off, the buffer cannot store data, so the computer must wait for the printer to print each character before sending the next character.

Buzzer (beep)

The printer beeps when an error occurs. See Chapter 7, “Troubleshooting,” for more information. If you do not want the printer to beep, turn off this feature.

Auto CR (carriage return)

When auto carriage return is on, each line feed (LF) code or ESC J code is accompanied by a carriage return (CR) code so the printer moves the next printing position to the left margin. When this feature is off, you must send a CR code after the line feed code to move the printing position to the left margin. This feature is available only in IBM emulation mode.

AGM (Alternate Graphics Mode)

When AGM is on, the printer can use advanced graphics commands like those available in ESC/ P 2 mode. This feature is available only in IBM emulation mode. The default setting is Off.

Font

In the default-setting mode, you can select from these six fonts: OCR-B, Orator, Orator-S, Script C, Roman T, and Sans Serif H. The following additional fonts are available only by pressing the **Font** button on the control panel: Draft, Roman, Sans Serif, Courier, Prestige, and Script. You cannot select the control panel fonts in the default-setting mode.

Changing the default settings

Follow the steps below to enter the default-setting mode and change the printer's default settings.

Note:

- ❑ *To print the language selection sheet and the default-setting mode instruction sheets, you need four sheets of A4 or letter size single-sheet paper or 11-inch or longer continuous paper. See Chapter 3, "Paper Handling," for instructions on loading single-sheet and continuous paper.*
- ❑ *If you use single-sheet paper to print the default-setting mode instruction sheets, be sure to load a new sheet of paper each time the printer ejects a printed sheet. Otherwise, you cannot proceed to the next step.*

1. Make sure paper is loaded, then turn off the printer. While holding down the **Font** button, press the **Operate** button to turn on the printer. The printer enters the default-setting mode and prints the language selection sheet.
2. Press the **Font** button until the **Font** lights indicate the language you want, as described on the language selection sheet.
3. Press the **Tear Off/Bin** button to print the default-setting mode instruction sheets (three pages) in the language you want.

Note:

The arrows on the instruction sheets indicate the printer's current settings.

4. Press the **Font** button until the **Font** lights indicate the option you want to change, as described on the default-setting mode instruction sheets.
5. Press the **Tear Off/Bin** button until the **Condensed** and **Tear Off/Bin** lights indicate the setting you want, as described on the instruction sheets.
6. Repeat steps 4 and 5 to make any other settings you want. Each time you press the **Tear Off/Bin** button, the printer saves the settings you selected.
7. When you finish changing the settings, press the **Operate** button to turn off the printer and exit the default-setting mode.

Using Quiet Mode

In quiet mode, the printer makes less noise when it prints. However, printing in quiet mode reduces the printing speed.

To turn on quiet mode, hold down the **Font** and **Condensed** buttons and press the **Operate** button to turn on the printer. To turn off quiet mode, press the **Operate** button to turn off the printer.

Chapter 5

Using Printer Options

Cut-Sheet Feeders	5-2
Installing the cut-sheet feeder	5-3
Loading paper from the cut-sheet feeder	5-6
Switching between the tractor and the cut-sheet feeder	5-13
Loading paper manually from the sheet guide	5-14
Roll Paper Holder	5-15
Installing the roll paper holder	5-15
Loading a roll of paper	5-17
Interface Cards	5-19
Installing an interface card	5-19
Using a serial interface card (C82305* or C82306*)	5-21



This chapter describes how to use optional equipment with your printer, including cut-sheet feeders, a roll paper holder, and interface cards.

Cut-Sheet Feeders

Two cut-sheet feeders are available for use with your printer:

Printer model	High capacity (bin 1)	Second bin (bin 2)
LQ-670	C80678*	C80679*

The asterisk (*) is a substitute for the last digit, which varies by country. Contact your local EPSON dealer for the part number in your country.

You can install the high-capacity cut-sheet feeder by itself, or you can assemble and install a double-bin cut-sheet feeder by combining the high-capacity and second-bin feeders. When the double-bin cut-sheet feeder is installed, the high-capacity cut-sheet feeder is used as bin 1 and the second-bin feeder is used as bin 2.

Note:

The second-bin feeder can be used only in combination with the high-capacity feeder.

Before you install a cut-sheet feeder, read the manual that comes with it. The cut-sheet feeder manual provides instructions on how to combine the two cut-sheet feeders to create the double-bin cut-sheet feeder.

You can load up to 150 single sheets of paper, 40 single-sheet multi-part forms, 25 envelopes, or 50 postcards in the high-capacity cut-sheet feeder (bin 1 of the double-bin feeder). You can load an additional 50 single sheets in the second-bin cut-sheet feeder (bin 2 of the double-bin feeder). With the double-bin cut-sheet feeder, you can load two different types or sizes of paper at one time.

Note:

For detailed paper specifications, see Appendix A.

Installing the cut-sheet feeder

The cut-sheet feeder comes with a sheet guide for stacking printed sheets. To install the cut-sheet feeder, you need to attach both the cut-sheet feeder and the sheet guide. Follow the steps below.

Note:

You install both the high capacity cut-sheet feeder and the double-bin cut-sheet feeder the same way, as described below. Before you install the double-bin cut-sheet feeder, however, assemble it as described in the cut-sheet feeder manual.

1. Make sure the printer is turned off.
2. Close the sprocket covers if they are open, and lock the sprocket units by pushing down the lock levers if necessary.

Note:

You do not need to remove your continuous paper from the tractor to use the cut-sheet feeder. For information on switching between the cut-sheet feeder and continuous paper, see page 5-13.

3. Move the paper release lever to the single-sheet position.
4. Hold the cut-sheet feeder by placing your hands on both sides of it. While holding down the buttons on both sides, fit the notches on each side of the feeder over the mounting posts on the printer. Lower the cut-sheet feeder until it rests on the printer.

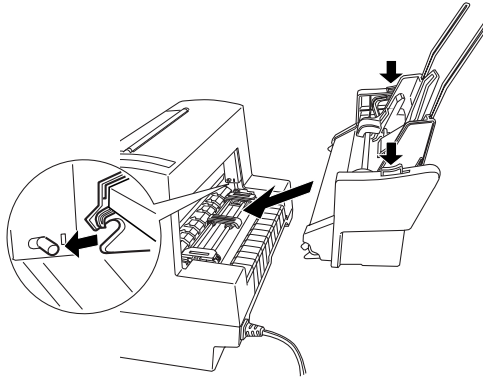

5. Remove the paper guide from the front of the printer. Then slide the sheet guide for the cut-sheet feeder all the way onto the mounting pegs.
6. Slide both the right and left edge guides as far to the sides as possible.

7. Pull out the sheet guide extension until it is fully extended.
(If you do not plan to stack the printed sheets, you do not need to perform this step.)

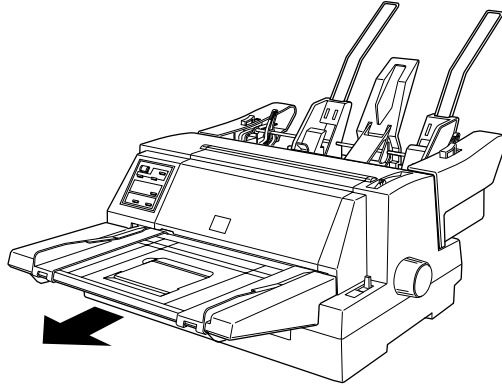

5

8. If you are printing on long paper, open the extension flap at the center of the sheet guide by lifting up its left side.

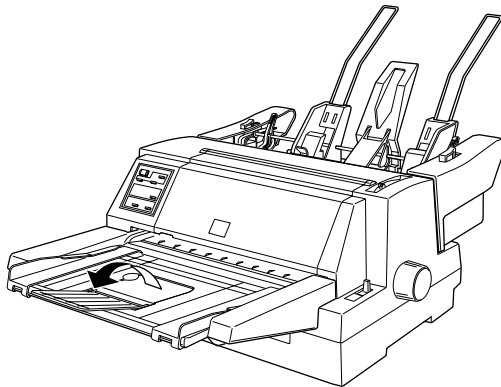

9. Press the **Operate** button to turn on the printer.

You are now ready to load paper with your cut-sheet feeder as described in the next section. To remove the cut-sheet feeder, reverse the steps above.

Note:

Even when you are not using the cut-sheet feeder, you can use its sheet guide instead of the standard paper guide; simply close the sheet guide's extension flap and push in the sheet guide extension, as shown below.

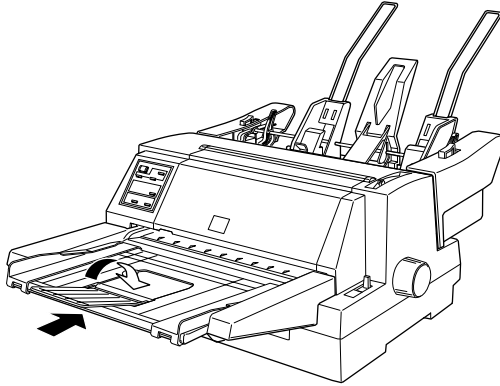

Loading paper from the cut-sheet feeder

This section describes how to load paper in the high-capacity and second-bin cut-sheet feeders.

Note:

- ❑ *Load single-sheet multi-part forms, envelopes, and postcards only in the high-capacity cut-sheet feeder (bin 1 of the double-bin cut-sheet feeder).*
- ❑ *For single-sheet multi-part forms, use only the type that are glued at the top of the forms.*
- ❑ *To avoid paper jams, do not allow the printer to stack more than 40 printed sheets on the sheet guide at one time.*

Loading paper from the high-capacity cut-sheet feeder

Load paper in the high-capacity cut-sheet feeder (bin 1 of the double-bin feeder) as follows:

1. Pull both paper set levers forward until the paper guides retract to allow paper loading.

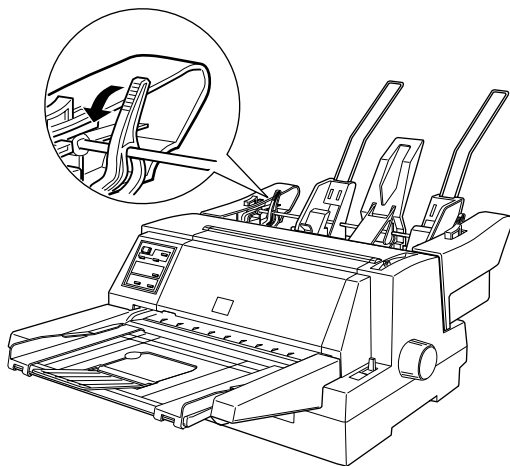

2. Release the paper guide lock levers by pulling them forward.

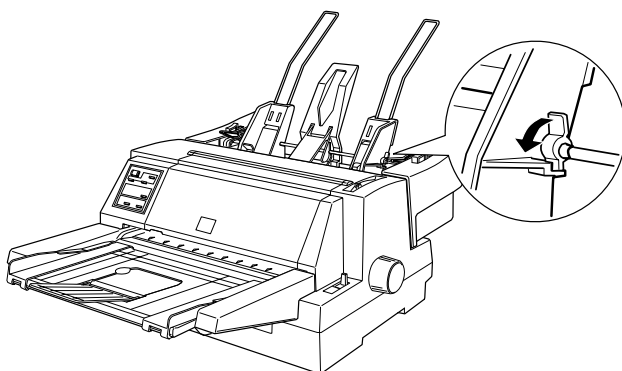

3. Slide the right paper guide so that its edge is even with the guide mark on the cut-sheet feeder and push back the lever to lock the paper guide in place. Next, slide the left paper guide to roughly match the width of your paper.

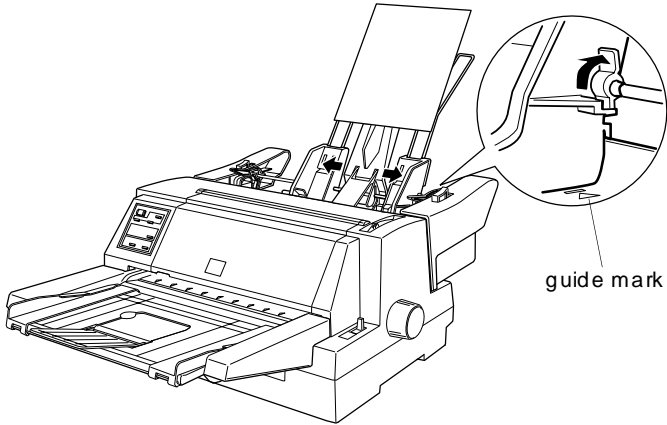

4. Slide the center support midway between the paper guides.

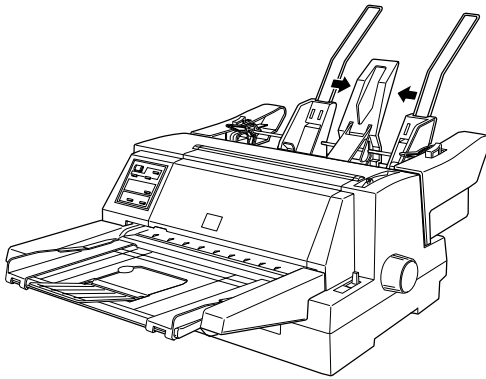

5. Fan a stack of paper (up to 150 sheets); then tap the sides and bottom of the stack on a flat surface to even it up.



Caution:

Do not use labels in the cut-sheet feeder.

6. Insert the paper along the right paper guide and adjust the position of the left paper guide so that it matches your paper's width. Make sure the position of the guide allows the paper to move up and down freely. Then lock the left guide in place.

Note:

Load paper with the printable side up. If you are using pre-printed forms, load the forms top-down.

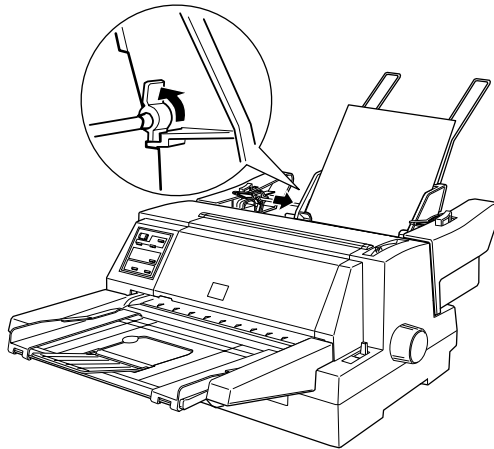

7. Push back the paper set levers to clamp the paper against the guide rollers.

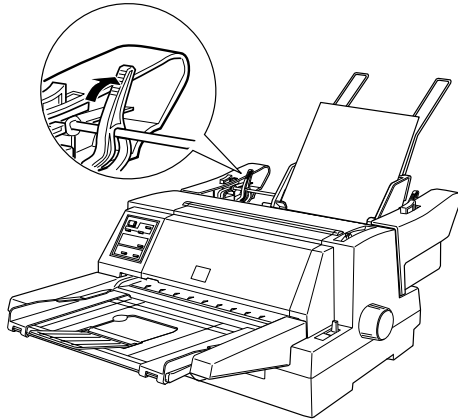

8. Before printing, make sure the paper release lever is set to the single-sheet position. Also set the paper thickness lever to the correct position for the paper loaded in the cut-sheet feeder, as described on page 3-6. In your printer driver software, select your paper size from the Paper Size list, and select **Sheet Feeder Bin-1** from the Paper Source list.

If you are printing from a DOS application, select the bin number using the **Tear Off/Bin** button on the control panel.

The cut-sheet feeder loads paper when you send data to the printer. You can also load paper by pressing the **Load/Eject** button.

Loading paper from the second-bin cut-sheet feeder

Follow the steps below to load paper in the second bin of the double-bin cut-sheet feeder.

Note:

You cannot use the second-bin cut-sheet feeder without the high-capacity cut-sheet feeder, although the illustrations here show only the second-bin feeder.

1. Pull both paper set levers forward, and slide the right paper guide to the guide mark and the left paper guide all the way to the left.

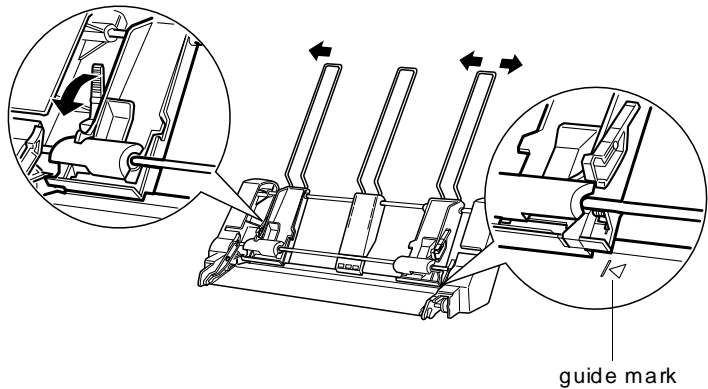

2. Load a fanned stack of paper (up to 50 sheets), aligning the right edge of the paper with the right paper guide. Be sure to load the paper with the printable side up. Adjust the left paper guide and center support to fit the paper, and then push back the paper set levers to lock the paper in place.

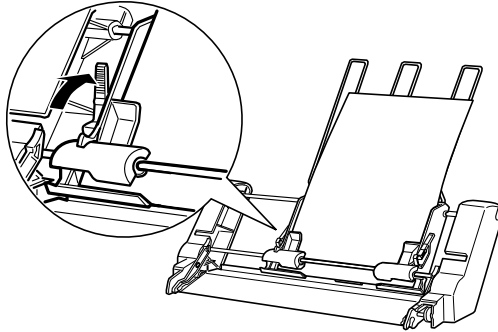

3. Before printing, make sure the paper release lever is set to the single-sheet position. Also set the paper thickness lever to the correct position for the paper loaded in the cut-sheet feeder, as described on page 3-6.
4. In your printer driver software, select your paper size from the Paper Size list, and select **Sheet Feeder Bin-2** from the Paper Source list.

If you are printing from a DOS application, select the bin number using the **Tear Off/Bin** button on the control panel.

The cut-sheet feeder loads paper when you send data to the printer. You can also load paper by pressing the **Load/Eject** button.

Switching between the tractor and the cut-sheet feeder

You can easily switch between continuous paper loaded from the tractor and single sheets loaded from the cut-sheet feeder without removing your continuous paper.

Switching to continuous paper

Follow the steps below to switch to continuous paper loaded from the tractor.

1. If any single sheets are in the paper path, press the **Load/Eject** button to eject them.
2. Move the paper release lever to the tractor position.
3. Make sure the sheet guide's extension flap is closed, and push the sheet guide extension all the way in.

Switching to single sheets

To switch back to single sheets loaded from the cut-sheet feeder, follow these steps:

1. If any continuous paper remains in the printer, press the **Tear Off/Bin** button to advance the paper to the tear-off position.
2. Tear off the printed pages.
3. Press the **Load/Eject** button. The printer feeds the paper backward to the standby position. The paper is still attached to the tractor but is no longer in the paper path.
4. Move the paper release lever to the single-sheet position.
5. Pull out the sheet guide extension, and open the extension flap if you are printing on long paper.

Loading paper manually from the sheet guide

The cut-sheet feeder's single-sheet loading feature allows you to switch to a different type or size of paper without replacing the paper already in the cut-sheet feeder or removing the feeder.

Follow these steps:

1. Make sure that the paper release lever is in the single-sheet position.
2. Set the paper thickness lever to the correct position for your paper, as described on page 3-6.
3. Close the sheet guide's extension flap if necessary, and push the sheet guide extension all the way in.
4. Slide the right edge guide until it is aligned with the guide mark on the sheet guide.
5. While adjusting the left edge guide to match the width of your paper, insert a sheet of paper between the edge guides until it meets resistance. Be sure to load your paper printable side up. After a few seconds, the printer automatically advances the paper to the loading position. The printer is ready to accept data from your computer and print.

After printing a sheet, the printer ejects the printed sheet onto the sheet guide and the **Paper Out** and **Pause** lights come on. If you are printing a multiple-page document, remove the printed sheet and insert a new sheet into the sheet guide. The printer automatically advances the paper and resumes printing.

Roll Paper Holder

The optional roll paper holder (#8310) allows you to use your printer with 8.5-inch roll paper like that used in telex machines.

Note:

This option is available only in some countries.

Installing the roll paper holder

To install the roll paper holder, follow the steps below.

1. Turn off the printer and make sure the paper release lever is at the single-sheet position.
2. Facing the back of the printer, slide both sprocket units and the right edge guide all the way to the right, and slide the left edge guide all the way to the left.

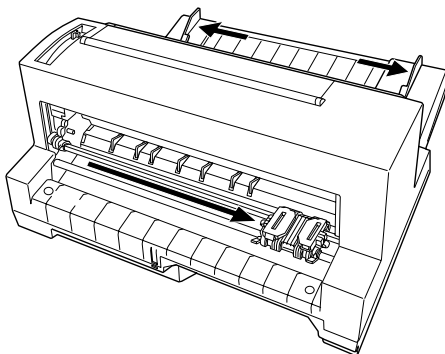

3. Position the roll paper holder beneath the printer as shown below. Fit the two holes in the roll paper holder base under the two positioning pegs on the bottom of the printer. Gently lower the printer so the positioning pegs slide into the holes.

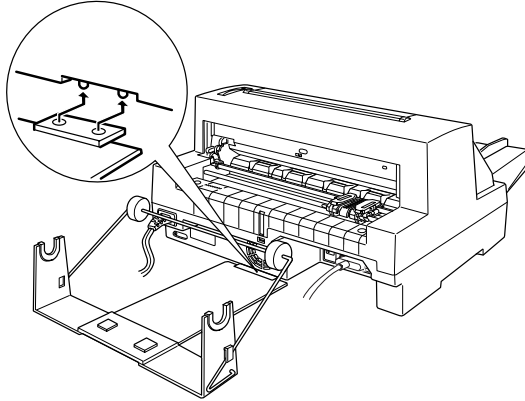

Caution:

Take care not to drop the roll paper holder when lifting the printer. Only the printer's weight holds it in place.

Loading a roll of paper

To load a roll of paper on the roll paper holder, follow these steps:

1. Cut the leading edge of the roll paper straight across. Slide the roll paper holder shaft through the center of the paper roll.

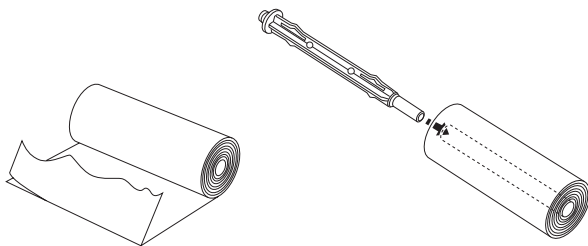

2. Set the shaft and paper roll onto the roll paper holder. Load the roll so the paper feeds from the top of the roll and the edge of the roll paper passes under the tension lever. Then press the **Operate** button to turn on the printer.

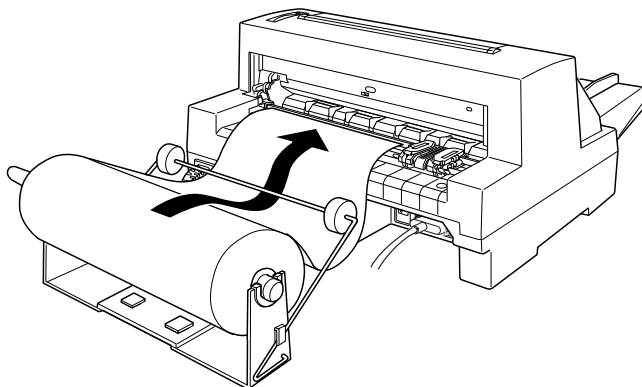

3. Bring the leading edge of the paper up over the paper path guide and insert it into the printer until you feel resistance. The printer loads the roll paper automatically.

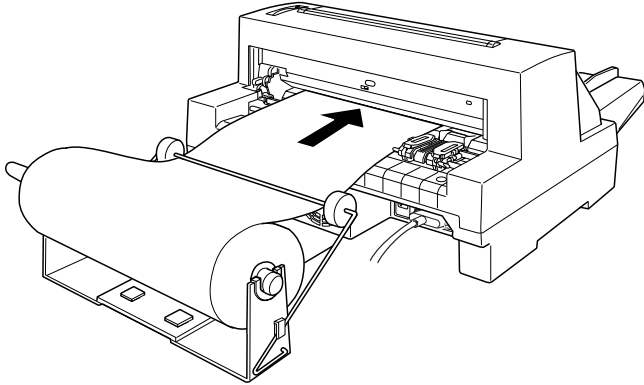

Interface Cards

You can use optional interface cards to supplement your printer's built-in parallel interface. The EPSON interface cards below are compatible with your printer. (Not all interfaces are available worldwide.)

Model number	Card type
C82305* / C82306*	Serial interface
C82307* / C82308*	32KB intelligent serial interface
C82310* / C82311*	32KB intelligent parallel interface
C82313*	32KB IEEE-488 interface
C82314*	Coax interface
C82315*	Twinax interface
C82331*	Ethernet interface
C82345*	IEEE-1284 parallel interface
C82346*	Multi Protocol Ethernet interface

The asterisk (*) is a substitute for the last digit, which varies by country.

If you are not sure whether you need an optional interface or would like to know more about interfaces, contact your dealer.

Installing an interface card

Follow the steps below to install an optional interface card.

1. Make sure the printer is turned off. Unplug the printer's power cord and disconnect the interface cable.

2. Remove the screws securing the shield plate to the back of the printer and remove the plate.

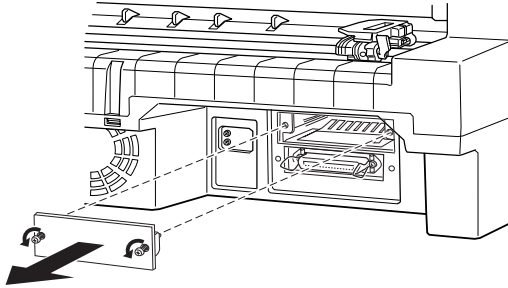

3. Slide the interface card along the slots on both sides of the interface compartment. Firmly push in the card to make sure the connector at the back of the card is fully inserted into the printer's internal socket. Then reinsert the screws and tighten them.

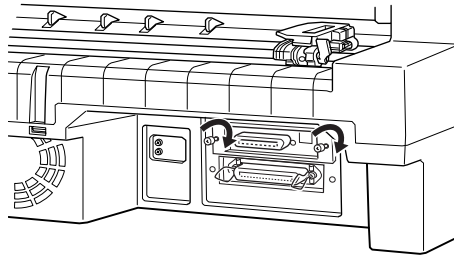

Note:

Store the shield plate in a safe place; you will need to reattach it if you remove the interface card.

To remove the interface card, reverse the steps above.

Using a serial interface card (C82305* or C82306*)

To use a serial interface card (C82305* or C82306*), see the sections below to set the correct baud rate, handshake timing, and error handling. For all other data transfer conventions, such as word structure and communications protocol, see your interface card manual.

Selecting a baud rate

You can select from the following baud rates: 300, 600, 1200, 2400, 4800, 9600, and 19200 bps (bits per second). To set the baud rate, see the bit-rate selection table in your interface card manual.

Handshake timing

When the unused area for data in the input buffer drops to 256 bytes, the printer outputs an X-OFF code or sets the DTR flag to 1 (MARK) to indicate that it cannot receive data. When the unused area increases to 512 bytes, the printer outputs an X-ON code or sets the DTR flag to 0 (SPACE) to indicate that it is ready to receive data.

Error handling

When the printer detects a parity error, it prints an asterik (*). The printer ignores all other errors, including framing and overrun errors.

Chapter 6

Maintenance and Transportation

Replacing the Ribbon Cartridge	6-2
Cleaning the Printer	6-5
Transporting the Printer	6-6

Replacing the Ribbon Cartridge

If your printing becomes faint, you may need to replace the ribbon cartridge. (See Chapter 7, “Troubleshooting,” for more information.) If you do need to replace the ribbon, EPSON recommends the use of the EPSON Ribbon Cartridge (S015016) for best results. Genuine EPSON ribbon cartridges are designed for your EPSON printer; their high quality ensures the proper operation and long life of the print head and other printer parts. Other products not manufactured by EPSON may cause damage to your printer not covered by EPSON’s warranties.

To replace the ribbon cartridge, follow these steps:

1. Press the **Operate** button to turn off the printer and then open the printer cover.

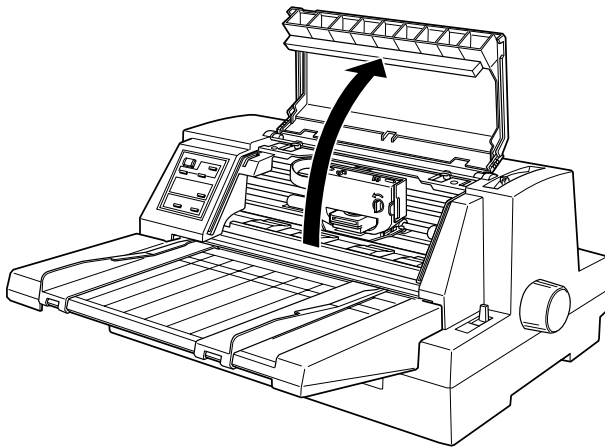

Warning:

If the printer has been used recently, the print head may be hot. Let it cool before attempting to replace the ribbon cartridge.

2. Make sure the print head is at the ribbon installation position (the middle position where the front metal plate is indented), as shown below. If the print head is not at this position, move the print head to the correct position.

Note:

The print head moves to the ribbon installation position automatically if the printer is on and no data is sent to the printer for several seconds.

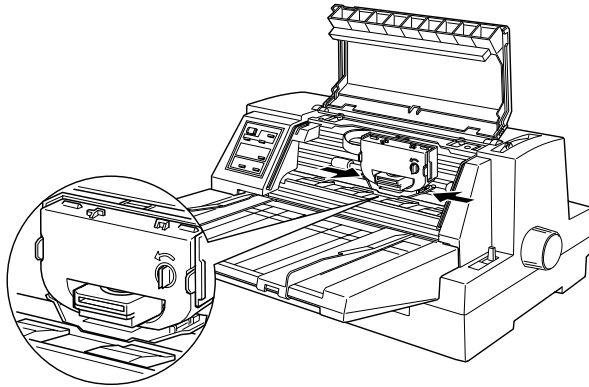

3. Squeeze the tabs on each side of the cartridge, and pull the cartridge out of the printer.

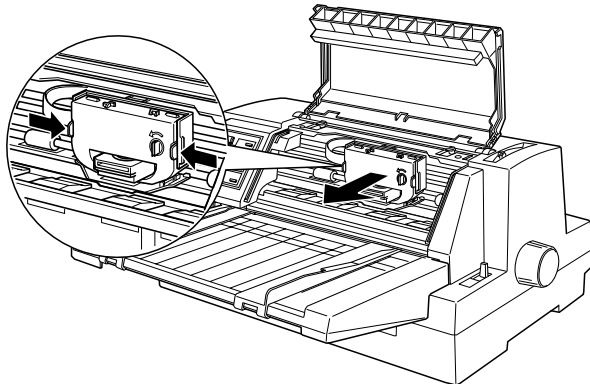

4. Remove the new ribbon cartridge from its package and turn the ribbon-tightening knob in the direction of the arrow to remove any slack in the ribbon.

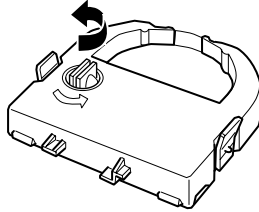

5. Hold the ribbon cartridge with the exposed ribbon down and the ribbon-tightening knob facing you, and guide the ribbon under the print head. Then snap the cartridge into place so that the tabs on both sides of the cartridge fit into the notches in the cartridge holder.

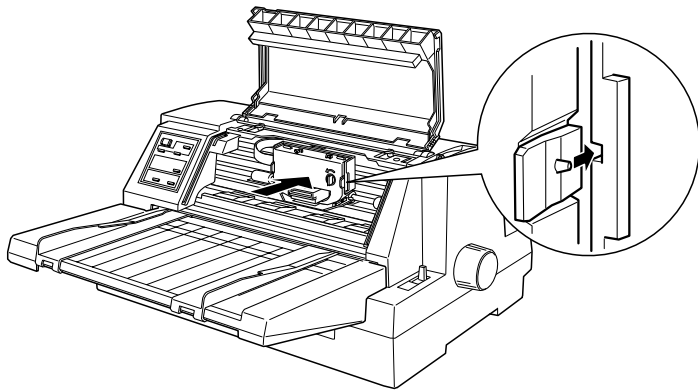

6. Turn the ribbon-tightening knob again to remove any slack in the ribbon and to make sure the ribbon moves freely.

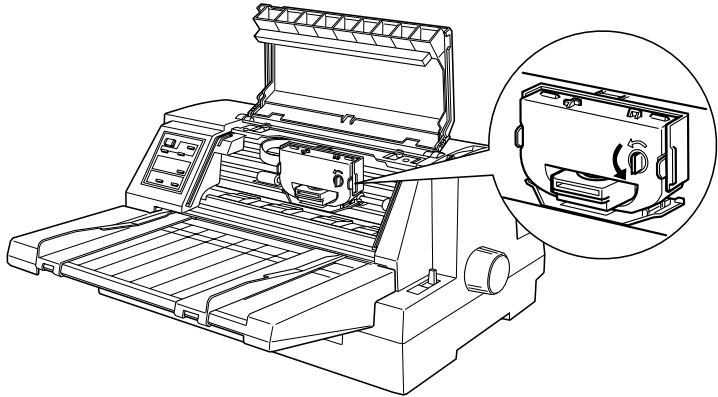

7. Close the printer cover.

Cleaning the Printer

To keep your printer operating at its best, you should clean it thoroughly several times a year. Follow these steps:

1. Turn off the printer and remove any paper as well as the paper guide. If an optional cut-sheet feeder is installed, remove it.
2. Use a soft brush to carefully brush away all dust and dirt from the other case.
3. If the outer case and the paper guide are still dirty or dusty, clean them with a soft, clean cloth dampened with mild detergent dissolved in water. Keep the printer cover closed to prevent water from getting inside the printer.



Caution:

- ❑ *Never use alcohol or thinners to clean the printer; these chemicals can damage the printer components as well as the case.*
- ❑ *Be careful not to get water on the printer mechanism or electronic components.*
- ❑ *Do not use a hard or abrasive brush.*
- ❑ *Do not spray the inside of the printer with lubricants; unsuitable oils can damage the printer mechanism. Contact your EPSON dealer if you think lubrication is needed.*

Transporting the Printer

If you need to transport your printer some distance, carefully repack it as described below, using the original box and packing materials.

1. Turn off the printer and remove any paper loaded in the printer.
2. Unplug the power cord from the electrical outlet; then disconnect the interface cable from the printer. If an optional cut-sheet feeder is installed, remove it.



Warning:

If the printer has been used recently, the print head may be hot. Let it cool before attempting to remove the ribbon cartridge.

3. Remove the paper guide. Remove the ribbon cartridge as described in steps 1 through 3 of “Replacing the Ribbon Cartridge” earlier in this chapter. Then close the printer cover.
4. Repack the printer, ribbon cartridge, paper guide, and power cord in the original packing materials and place them in the printer’s original box.

Chapter 7

Troubleshooting

Using the Error Indicators	7-3
Printing a Self Test	7-4
Using Hex Dump Mode	7-5
Problems and Solutions	7-6
Power supply	7-7
Paper handling	7-8
Operation	7-16
Printout	7-18
Clearing a Paper Jam	7-24
Using Bidirectional Adjustment Mode	7-24

This chapter describes what you can do if you are having problems printing. It is divided into these sections:

- ❑ Using the error indicators. This section describes how to use the control panel lights as error indicators so you can diagnose and fix printer problems.
- ❑ Printing a self test. This section explains how to run the printer's self test to determine whether the problem lies with the printer or the computer.
- ❑ Using hex dump mode. This section describes the printer's hex dump mode. Experienced users may want to use this mode to pinpoint communication problems.
- ❑ Problems and solutions. This section describes how to solve problems with the power supply, paper handling, printer operation, and the quality of the printout.
- ❑ Clearing a paper jam. This section shows you how to clear a paper jam.
- ❑ Using bidirectional adjustment mode. This section explains how to use the bidirectional adjustment feature to ensure that vertical lines are properly aligned in your printout.

Use the information in this chapter to pinpoint the source of your printer problem, and then try the recommended solutions. If none of these solution fixes your problem, see Appendix C, "Contacting Customer Support."

Using the Error Indicators

You can identify many common printer problems using the lights on the control panel. If your printer stops working and one or more control panel lights are on or flashing, use the following table to diagnose and fix the problem.

State of panel light	Beep pattern	Problem
		Solution
<input type="checkbox"/> Paper Out <input type="checkbox"/> Pause	•••	No paper is loaded for the selected paper source. Load paper in the printer; the Paper Out and Pause lights go off and the printer resumes printing.
	•••	The paper is not loaded correctly. Remove and reload your paper correctly. See Chapter 3 for instructions on how to load the type of paper you want to use.
	•••••	The paper release lever is set to the wrong position. Set the paper release lever to the position that matches the paper loaded in the printer.
<input type="checkbox"/> Paper Out <input type="checkbox"/> Pause	•••	Single-sheet paper is not fully ejected. Remove the paper by hand; the Paper Out light goes off.
	•••••	Paper is jammed in the printer. To clear the paper jam, see "Clearing a Paper Jam" on page 7-24.
<input type="checkbox"/> Pause	–	The print head is overheated. Wait a few minutes; the printer resumes printing automatically once the print head cools.
<input type="checkbox"/> Paper Out <input type="checkbox"/> Pause <input type="checkbox"/> Font <input type="checkbox"/> Condensed <input type="checkbox"/> Tear Off/Bin	–	An unknown printer error has occurred.
		Turn off the printer and leave it off for several minutes; then turn on the printer again. If the error recurs, contact your dealer.

= on, = flashing

••• = short interval, ••••• = long interval

Printing a Self Test

Running the printer's self test helps you determine whether the problem comes from the printer or the computer:

- ❑ If the self test results are satisfactory, the printer is working properly and the problem is probably caused by your printer driver settings, application settings, computer, or interface cable. (Be sure to use a shielded interface cable.)
- ❑ If the self test does not print properly, there is a problem with the printer. See “Problems and Solutions” for possible causes and solutions to the problem.

You can run the self test with either single sheets or continuous paper. This section describes how to run the test with single-sheet paper. See Chapter 3 for information on loading and using continuous paper.

To perform a self test, follow these steps:

1. Make sure paper is loaded in the paper guide or on the tractor, and the paper release lever is set to the correct position for your paper. Then turn off the printer.



Caution:

Whenever you turn off the printer, wait at least five seconds before turning it back on; otherwise you may damage the printer.

2. To run the test using the Draft font, hold down the **LF/FF** button while you press the **Operate** button to turn on the printer. To run the test using the printer's letter-quality fonts, hold down the **Load/Eject** button while you turn on the printer. Either self test can help you determine the source of your printing problem; however, the draft self test prints faster than the letter-quality test. See pages 4-5 and 4-6 for more information on using fonts.

After a few seconds, the printer loads the paper automatically, and then begins printing the self test. A series of characters is printed.

Note:

*To temporarily stop the self test, press the **Pause** button. To resume the test, press the **Pause** button again.*

3. To end the self test, press the **Pause** button to stop printing. If paper remains in the printer, press the **Load/Eject** button to eject the printed page. Then turn off the printer.



Caution:

*Do not turn off the printer while it is printing. Always press the **Pause** button to stop printing, and the **Load/Eject** button to eject the printed page before you turn off the printer.*

Using Hex Dump Mode

If you are an experienced user or a programmer, you can print a hexadecimal dump to isolate communication problems between the printer and your software program. In hex dump mode, the printer prints all data it receives from the computer as hexadecimal values.

To print a hex dump, follow the steps below.

1. Make sure that A4 (210 × 297 mm, 8.3 × 11.7 inches) or wider paper (such as letter size paper) is loaded in the printer.
2. To enter hex dump mode, hold down both the **LF/FF** and **Load/Eject** buttons while you press the **Operate** button to turn on the printer.

3. Open a software program and send a print job to the printer. Your printer prints all the codes it receives in hexadecimal format.

By comparing the characters printed in the right column with the printout of the hexadecimal codes, you can check the codes being received by the printer. If characters are printable, they appear in the right column as ASCII characters. Nonprintable codes, such as control codes, are represented by dots.

4. To turn off hex dump mode, press the **PAUSE** button, eject the printed page(s), and then turn off the printer.

Problems and Solutions

This section divides printer problems into four categories:

Power supply	page 7-7
Paper handling	page 7-8
Operation	page 7-16
Printout	page 7-18

See the section for the type of problem you have and look for the description of your problem. The most likely causes and solutions are listed first, so try the solutions in the order in which they appear.

Power supply

The lights come on briefly but then go off and stay off.

Cause	What to do
The printer's voltage rating does not match the voltage of your electrical outlet.	Check the printer and the outlet voltage ratings. If the voltages do not match, unplug the printer immediately and contact your dealer.



Warning:

Do not reconnect the power cord to an electrical outlet with the wrong voltage for your printer.

The printer does not work and the control panel lights are off.

Cause	What to do
The printer is turned off.	Press the Operate button. Some control panel lights come on.
The power cord is not properly plugged into the electrical outlet; or if your power cord is not permanently attached to your printer, the power cord is not properly plugged into the printer.	Press the Operate button to turn off the printer, and make sure the power cord is firmly plugged into the electrical outlet and the printer, if necessary. Then press the Operate button to turn on the printer.
The electrical outlet is controlled by an outside switch or automatic timer.	Use a different outlet.
The electrical outlet is out of order.	Plug another electrical device, such as a lamp, into the outlet to check if the outlet is working properly. If it is not, use a different outlet.

Paper handling

Single sheets loaded from the paper guide

The printer does not load single-sheet paper.

Cause	What to do
Continuous paper is in the paper path.	Remove the continuous paper. Set the paper release lever to the single-sheet position and insert a new sheet. (See Chapter 3 for information on removing continuous paper.)
The paper release lever is set to the tractor position.	Set the paper release lever to the single-sheet position. (See “Setting the paper release lever” in Chapter 3.)

The platen does not rotate and the printer does not feed the paper.

Cause	What to do
The paper on the paper guide is positioned too far to the left or right for the paper sensor to detect it.	Move the paper a little to the left or right.

The platen rotates but the printer does not feed the paper.

Cause	What to do
The edge guides are pressed too tightly against the paper.	Reinsert the paper all the way into the printer. Make sure that the edge guides are not too close to the paper.
The paper release lever is set to the tractor position.	Set the paper release lever to the single-sheet position. See “Setting the paper release lever” in Chapter 3.

Paper feeding is crooked or the paper jams.

Cause	What to do
The paper guide is not properly installed.	Remove the paper guide and install it as described in “Attaching the paper guide” in Chapter 1.
The edge guides are not positioned correctly.	Move the edge guides so that they match the width of your paper.
You may not be using the right type of paper for the printer.	Be sure you’re using the right type of paper. See the paper specifications in Appendix A.
The paper is old or creased.	Use only new, clean sheets of paper.

Note:

If paper is jammed in the paper path, see “Clearing a Paper Jam” later in this chapter.

The printer does not fully eject the paper.

Cause	What to do
You may not be able to fully eject your paper using the LF/FF button.	Use the Load/Eject button to eject the paper.
Your paper may be too long.	Make sure the page length of your paper is within the specified range. See the single-sheet paper specifications in Appendix A. Also check and adjust the paper size setting in your application or the printer driver.

When the printer ejects the paper, the Paper Out light flashes and the Pause light comes on.

Cause	What to do
The printer has not fully ejected your paper.	Remove the paper by hand; the Paper Out light goes out. If you are printing a multiple-page document, insert a new sheet of paper into the paper guide. The Pause light goes out and the printer automatically loads the paper and resumes printing.

Continuous paper

The printer does not load continuous paper.

Cause	What to do
The paper release lever is set to the single-sheet position.	Set the paper release lever to the tractor position. See “Setting the paper release lever” in Chapter 3.
The paper has come off the tractor.	Reattach the paper to the tractor as described in “Loading continuous paper with the tractor” in Chapter 3.

When you send data or press the Load/Eject button, the platen rotates but the printer does not feed the paper.

Cause	What to do
The paper release lever is set to the single-sheet position.	Move the paper release lever to the tractor position.
The paper has come off the tractor.	Reattach the paper to the tractor as described in “Loading continuous paper with the tractor” in Chapter 3.
The paper has been fed back to the standby position.	Press the Load/Eject button to load the paper.

Paper feeding is crooked or the paper jams.

Cause	What to do
The paper supply is obstructed.	Make sure the paper supply is not obstructed by a cable or some other object.
The paper supply is not aligned with the printer.	Make sure you align your paper supply with the paper loaded in the tractor so the paper feeds smoothly into the printer. See “Positioning your continuous paper supply” in Chapter 3.
The paper supply is too far away from the printer.	Make sure that your paper supply is within 1 meter (3 feet) of the printer.
The holes on the sides of the paper are misaligned.	Check that the holes on the sides of the paper are aligned with each other. Also make sure the sprocket units are locked and their covers are closed.
The paper thickness lever is set incorrectly.	Set the paper thickness lever to match the thickness of your paper. See “Adjusting the paper thickness lever” in Chapter 3.
Your paper may be the wrong size or thickness for the printer.	Make sure that the paper size and thickness are within the specified ranges. See the continuous paper specifications in Appendix A.
The sprocket units are positioned incorrectly for the width of paper you are using.	Adjust the position of the sprockets to remove any slack along the width of the paper.

Note:

If paper is jammed in the paper path, see “Clearing a Paper Jam” later in this chapter.

The top-of-form position of your continuous paper varies when you print several pages.

Cause	What to do
The paper size setting in your application or the printer driver may not match the size of the paper you are using.	Check the paper size setting in your application or the printer driver.
The printer's page length setting may not match the size of the paper you are using.	Check the "Page length for tractor" setting using the printer's default-setting mode or the EPSON Remote! utility. See "Using the Default-Setting Mode" in Chapter 4, or "Using the EPSON Remote! printer utility" in Chapter 2.
Your paper may be too heavy.	Make sure that the weight of your paper is within the specified range. See the continuous paper specifications in Appendix A.

The printer prints on (or too far away from) the perforation of your continuous paper.

Cause	What to do
The tear-off position is set incorrectly.	Adjust the tear-off position using the LF/FF or Load/Eject button. See "Adjusting the tear-off position" in Chapter 3.
The paper size setting in your application or the printer driver may not match the size of the paper you are using.	Check the paper size setting in your application or the printer driver.

The printer's page length setting may not match the size of the paper you are using.

Check the "Page length for tractor" setting using the printer's default-setting mode or the EPSON Remote! utility. See "Using the Default-Setting Mode" in Chapter 4, or "Using the EPSON Remote! printer utility" in Chapter 2.

The printer does not eject your continuous paper properly.

Cause

What to do

You may be trying to feed too much paper backward.

If you are using normal continuous paper, tear off the last printed page and press the **Load/Eject** button to feed the paper backward. If you are using labels, tear off the paper entering the printer, and then press the **LF/FF** button to feed the labels forward.

Your paper may be too long or too short.

Make sure the page length of your paper is within the specified range. See the continuous paper specifications in Appendix A.

The paper size setting in your application or the printer driver may not match the size of the paper you are using.

Check the paper size setting in your application or the printer driver.

The printer's page length setting may not match the size of the paper you are using.

Check the "Page length for tractor" setting using the printer's default-setting mode or the EPSON Remote! utility. See "Using the Default-Setting Mode" in Chapter 4, or "Using the EPSON Remote! printer utility" in Chapter 2.

Paper is jammed inside the printer.

Clear the paper jam as described on page 7-24.

Single sheets loaded from the optional cut-sheet feeder

The platen rotates but the cut-sheet feeder does not feed the paper.

Cause	What to do
The cut-sheet feeder is installed incorrectly.	Reinstall it correctly . See “Installing the cut-sheet feeder” in Chapter 5.
The paper release lever is set to the tractor position.	Set the paper release lever to the single-sheet position. (See “Setting the paper release lever” in Chapter 3.)
The right and left paper guides are too close to the paper stack, preventing the paper from feeding smoothly.	Adjust the paper guides to match the width of your paper.
Paper is jammed inside the printer.	Clear the paper jam as described on page 7-24.
There are only a few sheets of paper left in the bin.	Add more paper.
You may have loaded the wrong type of paper in bin 2 of the double-bin cut-sheet feeder.	Use only the high-capacity feeder (bin 1) or the sheet guide for single-sheet multi-part forms (only the type glued at the top of the forms in bin 1), for envelopes, or for postcards.
You may have loaded too many sheets in the bin.	Remove some sheets. The high-capacity feeder (bin 1) can hold up to 150 sheets of standard bond paper, 40 single-sheet multi-part forms, 25 plain or bond envelopes, 30 airmail envelopes, or 50 postcards. The second-bin feeder (bin 2) can hold up to 50 sheets of standard bond paper.

The cut-sheet feeder feeds more than one sheet at a time.

Cause	What to do
You may have loaded too many sheets in the bin.	Remove some sheets. The high-capacity feeder (bin 1) can hold up to 150 sheets of standard bond paper, 40 single-sheet multi-part forms, 25 plain or bond envelopes, 30 airmail envelopes, or 50 postcards. The second-bin feeder (bin 2) can hold up to 50 sheets of standard bond paper.
Sheets of paper are stuck together.	Remove the paper stack, fan it, and then reload it.

Paper feeding is crooked.

Cause	What to do
The right and left paper guides are too far apart.	Position the paper guides to match the width of your paper.
The paper is old or creased.	Use only new, clean sheets of paper.
You may not be using the right type of paper for the cut-sheet feeder. For example, your paper may be too heavy or too light.	Make sure your paper meets the requirements of your printer and cut-sheet feeder. See the paper specifications and the optional cut-sheet feeder specifications in Appendix A.

When the printer ejects the paper, the Paper Out light flashes and the Pause light comes on.

Cause	What to do
The printer has not fully ejected your paper.	Remove the paper by hand; the Paper Out light goes out. Press the Pause button to resume printing.

When you try to load single-sheet paper manually, the printer loads the paper from the cut-sheet feeder.

Cause	What to do
The paper was not properly loaded in the sheet guide.	Load the paper in the sheet guide as described on page 5-14.

One page of your document is printed on two pages.

Cause	What to do
The paper size setting in your application software does not match the size of the paper loaded in the printer.	Adjust the paper size setting in your application or the printer driver.

The printer does not load the paper you want when you switch between the cut-sheet feeder and the tractor.

Cause	What to do
The paper release lever is set incorrectly.	Move the lever forward to load continuous paper, or backward to load single sheets.

Operation

The Pause light is off but the printer does not print.

Cause	What to do
The interface cable is not plugged in securely.	Check that both ends of the cable between the printer and the computer are plugged in securely. If the cable is connected correctly, run a self test as described earlier in this chapter.

Your interface cable does not meet the printer and/ or computer specifications. Use an interface cable that meets the requirements of both the printer and computer. See page 1-10 and your computer documentation.

Your software is not properly set up for your printer. Make sure that your printer is properly selected in your application software. If necessary, install or reinstall the printer driver software as described in Chapter 2.

The Paper Out and Pause lights are on and the printer does not print.

Cause	What to do
The printer is out of paper for the selected paper source.	Make sure the paper release lever is in the correct position, and load paper in the current paper source. Press the Pause button to resume printing.
Paper on the paper guide is positioned too far to the left or right for the paper sensor to detect it.	Move the paper a little to the right or left. When it is positioned properly, the Paper Out and Pause lights go off.

The printer sounds like it is printing, but nothing prints.

Cause	What to do
The ribbon cartridge is not installed properly.	Install the ribbon cartridge as described in Chapter 1.
The ribbon is worn out.	Replace the ribbon cartridge as described in Chapter 6.
The paper thickness lever is set incorrectly.	Set the paper thickness lever to match the thickness of your paper. See “Adjusting the paper thickness lever” in Chapter 3.

The printer makes a strange noise and stops abruptly.

Cause	What to do
The paper is jammed.	Clear the paper jam as described on page 7-24.
The ribbon is jammed because it has too much slack or it is worn out.	Remove any slack from the ribbon by turning the ribbon-tightening knob, or replace the ribbon cartridge as described in Chapter 6.

The printer stops printing and the **Pause light flashes.**

Cause	What to do
The print head is overheated.	Wait a few minutes; the printer resumes printing automatically once the print head cools.

Printout**Part of the printout is missing, or dots are missing in random positions.**

Cause	What to do
The ribbon cartridge is not installed properly.	Reinstall the ribbon cartridge as described in Chapter 1.
There is too much slack in the ribbon or the ribbon has come loose.	Remove any slack in the ribbon by turning the ribbon-tightening knob, or replace the ribbon cartridge as described in Chapter 6.

Lines of dots are missing in the printout.

Cause	What to do
The print head is damaged.	Stop printing and contact your dealer to have the print head replaced.



Warning:

Never replace the print head yourself because other parts of the printer must be checked at the same time.

Incorrect characters are printed.

Cause	What to do
Your printer and the computer may not be communicating correctly.	Make sure that you use the correct interface cable and that the communications protocol is correct. See page 1-10 and your computer documentation. If you installed the optional serial interfacecard, also see page 5-19.
The wrong character table is selected in your software.	Select the correct character table in your software or using the default-setting mode or the EPSON Remote! utility. Note that the character table setting in your software overrides the settings made in the default-setting mode or EPSON Remote!.

The typestyles or characters set in your application software cannot be printed.

Cause	What to do
Your application software is not correctly configured for your printer.	Make sure that your application software is correctly configured for your printer. See your application documentation.

The printer does not print the font you selected using the default-setting mode, the EPSON Remote! utility, or the control panel buttons.

Cause	What to do
Software settings override settings you make in the default-setting mode, EPSON Remote!, or with the control panel buttons.	Use your software to select the font.

Printing starts too high or too low on the page.

Cause	What to do
The paper size settings in your application software do not match the size of the paper loaded in the printer.	Change the paper size settings in your application software or printer driver to match the size of the paper you are using.

The top margin or loading position setting is incorrect.

Check and adjust the margin and loading position settings in your software. See the printable area specifications in Appendix A.

Adjust the loading position in micro-adjust mode. However, settings made in Windows applications override settings made in micro-adjust mode. See “Adjusting the loading position” in Chapter 3.

Top margin and loading position settings made in your Windows applications override setting you make in the micro-adjust mode.

Use your application software to make these settings.

Note:

If you want to eliminate the top margin and print at the very top of the page, adjust the top margin in your Windows application little by little until text is printed at the very top of the page.

All the text is printed on the same line.

Cause

What to do

No line feed command is sent at the end of each line of text.

Turn on the auto line feed option in the default-setting mode or the EPSON Remote! utility so that the printer automatically adds a line feed code to each carriage return. See “Using the Default-Setting Mode” in Chapter 4, or “Using the EPSON Remote! printer utility” in Chapter 2.

The printout has extra blank lines between lines of text.

Cause	What to do
Two line feed commands are being sent at the end of each line of text.	Turn off the auto line feed option in the default-setting mode or the EPSON Remote! utility. See “Using the Default-Setting Mode” in Chapter 4, or “Using the EPSON Remote! printer utility” in Chapter 2.
The line space setting in your application software is incorrect.	Adjust the line space setting in your application software.

The length of the printing on the page does not match your paper length.

Cause	What to do
The paper size setting in your application or the printer driver may not match the size of the paper you are using.	Check the paper size setting in your application or the printer driver.
The printer’s page length setting may not match the size of the paper you are using.	Check the “Page length for tractor” setting using the printer’s default-setting mode or the EPSON Remote! utility. See “Using the Default-Setting Mode” in Chapter 4, or “Using the EPSON Remote! printer utility” in Chapter 2.

Printing starts lower on the page than you expect, or the bottom of a page is printed at the top of the next page.

Cause	What to do
The lines-per-page, top and bottom margin, or form length setting is incorrect.	<p>Adjust these settings in your application software, as follows:</p> <p>If your application software has a lines-per-page setting, set it to 66 for letter size paper or 70 for A4 size paper.</p> <p>If your software does not have a lines-per-page setting, try decreasing the top margin or increasing the bottom margin, or both, until you get the results you want.</p> <p>Adjust the form length setting if your software has this option.</p>

Vertical printed lines are not aligned.

Cause	What to do
Bidirectional printing, which is the printer's standard printing mode, may be out of alignment.	Use the printer's bidirectional adjustment mode to correct this problem. See "Using Bidirectional Adjustment" later in this chapter.

Clearing a Paper Jam

To clear a paper jam, follow these steps:

- 1 Press the **Operate** button to turn off the printer.
- 2 Open the printer cover.
- 3 If continuous paper is loaded in the printer, remove it as described in “Removing continuous paper” in Chapter 3. If continuous paper is jammed in the printer, tear off the fresh supply at the back of the printer.
- 4 Turn the knob on the right side of the printer toward you to remove the paper. Remove any remaining pieces.
- 5 If the paper is stuck where the printer ejects it, gently pull the paper out of the printer.
- 6 Close the printer cover and press the **Operate** button to turn on the printer. Make sure the **Paper Out** light is not flashing and the **Pause** light is off.



Caution:

Use the knob on the right side of the printer only to clear paper jams when the printer is off. Otherwise, you may damage the printer or change the top-of-form position.

Using Bidirectional Adjustment Mode

If you notice that the vertical lines in your printout are not properly aligned, you can use the printer’s bidirectional adjustment mode to correct this problem.

During bidirectional adjustment, the printer prints three sheets of alignment patterns, labeled Draft, Draft Copy, and LQ. As described below, you select the best alignment pattern from each sheet.

Follow the steps below to perform bidirectional adjustment.

Note:

- ❑ *To print the instruction sheet and alignment patterns, you need four sheets of A4 or letter size single-sheet paper or 11-inch or longer continuous paper. (See Chapter 3, “Paper Handling,” for instructions on loading single-sheet or continuous paper.)*
 - ❑ *If you use single-sheet paper, be sure to load a new sheet of paper each time the printer ejects a printed sheet. Otherwise, you cannot proceed to the next step.*
1. Make sure paper is loaded, then turn off the printer. While holding down the **Pause** button, press the **Operate** button to turn on the printer. The printer enters the bidirectional adjustment mode and then prints the instruction sheet and the first set of alignment patterns.
 2. As described on the instruction sheet, compare the alignment patterns and select the pattern with the best alignment. To specify the pattern number you want, press the **LF/FF** button (to decrease to the number) or the **Load/Eject** button (to increase to the number) until the **Font** lights correspond to the correct number as indicated at the bottom of the instruction sheet.
 3. Press the **Font** button to save your selection and print the next set of alignment patterns. Then repeat step 2 to select the best alignment pattern.
 4. Press the **Font** button again to save your selection and print the final set of alignment patterns.
 5. Select the best pattern in the final set of alignment patterns as described in step 2 and then press the **Font** button to save your selection.
 6. Press the **Operate** button to turn off the printer and exit the bidirectional adjustment mode.

Appendix A

Specifications

Technical Specifications	A-2
Printing	A-2
Paper	A-4
Mechanical	A-9
Electrical	A-10
Environmental	A-10
Safety approvals	A-11
CE marking	A-11
Parallel Interface Specifications	A-12
Forward channel	A-12
Reverse channel	A-12
Optional Cut-Sheet Feeder Specifications	A-13



Technical Specifications

Printing

Printing method: 24-pin impact dot matrix

Printing speed:

Characters per inch	Quality	Characters/second/line
10 cpi	High speed draft	300
10 cpi	Normal draft	250
10 cpi	Letter quality	83
12 cpi	Draft	300
12 cpi	Letter quality	100

*The paper thickness lever position or an overheated print head may affect the printing speed.

Printing direction: Bidirectional logic seeking for text and graphics printing. Unidirectional text or graphics printing can be selected using software commands.

Line spacing: 1/ 6-inch or programmable in 1/ 360-inch increments

Paper feed speed:

Continuous 5 inches/ second
Intermittent 60 ms/ line at 1/ 6-inch line spacing

Printable columns:

Characters per inch	Maximum printed characters per column
10 cpi	106
12 cpi	127
15 cpi	159
17 cpi	181
20 cpi	212

Buffer: 64KB or 0KB (selectable in the default-setting mode or the EPSON Remote! utility)

Bitmap fonts:

Font	Characters per inch available
EPSON Draft	10, 12, 15
EPSON Roman	10, 12, 15, proportional
EPSON Sans Serif	10, 12, 15, proportional
EPSON Courier	10, 12, 15
EPSON Prestige	10, 12
EPSON Script	10
EPSON Script C	proportional
EPSON Orator	10
EPSON Orator S	10
EPSON OCR-B	10

Scalable fonts:

Font	Available sizes
EPSON Roman	10.5, 8 to 32 points, in 2-point increments
EPSON Sans Serif	10.5, 8 to 32 points, in 2-point increments
EPSON Roman T	10.5, 8 to 32 points, in 2-point increments
EPSON Sans Serif H	10.5, 8 to 32 points, in 2-point increments

Barcode fonts: EAN-13, EAN-8, Interleaved 2 of 5, UPC-A, UPC-E, Code 39, Code 128, POSTNET

Character tables: One italic and 10 graphics character tables. (There are 19 graphics character tables available in certain areas.)

Character sets: 14 international character sets and one legal character set

Paper

Note:

Use recycled paper, labels, envelopes, and postcards only under normal temperature and humidity conditions, as follows:

Temperature	15° to 25°C (59° to 77°F)
Humidity	30% to 60% RH

Paper storage conditions:

Temperature	18° to 22°C (64° to 72°F)
Humidity	40% to 60% RH

Single sheets:

Width	92 to 297 mm (3.6 to 11.7 inches)
Length	92 to 420 mm (3.6 to 16.5 inches)
Thickness	0.065 to 0.14 mm (0.0025 to 0.0055 inches)
Weight	52.3 to 90 g/ m ² (14 to 24 lb)
Quality	Plain paper, bond paper, and recycled paper

Single-sheet multi-part forms:

Width	92 to 297 mm (3.6 to 11.7 inches)
Length	92 to 420 mm (3.6 to 16.5 inches) 92 to 297 mm (3.6 to 11.7 inches)* *For the type glued at the side of the form
Copies	1 original + 4 copies
Total thickness	0.12 to 0.39 mm (0.0047 to 0.015 inches)
Weight/ part	40 to 58 g/ m ² (12 to 15 lb)
Quality	Carbonless multi-part forms with a line of glue at the top or the side of the form

Continuous paper (ordinary and multi-part):

Width	101 to 304.8 mm (4.0 to 12.0 inches)
Length/ page	101 to 559 mm (4.0 to 22.0 inches)
Copies	1 original plus 4 copies
Total thickness	0.065 to 0.39 mm (0.0025 to 0.015 inches)
Weight	
Ordinary paper	52.3 to 82 g/ m ² (14 to 22 lb)
Part of multi-part form	40 to 58.2 g/ m ² (12 to 15 lb)
Quality	Plain paper, recycled paper, and carbonless multi-part forms with spot gluing or paper stapling on both sides

Labels:

Note:

Use only labels mounted on continuous backing sheets.

Size	
Width	63.5 mm (2.5 inches), minimum
Height	23.8 mm (0.94 inches) minimum
Backing sheet	
Width	101 to 304.8 mm (4.0 to 12.0 inches)
Length/ page	101 to 559 mm (4.0 to 22.0 inches)
Thickness	
Backing sheet	0.07 to 0.09 mm (0.0028 to 0.0035 inches)
Total thickness	0.16 to 0.19 mm (0.0063 to 0.0075 inches)
Weight	68 g/ m ² (17 lb)

Envelopes:

Size	No. 6 165 × 92.1 mm (6.5 × 3.6 inches)
	No. 10 241 × 105 mm (9.5 × 4.1 inches)
Thickness	0.16 to 0.52 mm (0.0063 to 0.020 inches) Any differences in thickness within the printable area must be less than 0.25 mm (0.0098 inches).
Weight	45 to 91 g/ m ² (12 to 24 lb)
Quality	Bond envelopes, plain envelopes, and airmail envelopes without glue on the flap

Postcards:

Width	105 to 148 mm (4.13 to 5.83 inches)
Length	147 to 148 mm (5.8 to 5.83 inches)
Thickness	0.22 mm (0.0087 inches)
Weight	192 g/ m ² (51 lb)
Quality	Plain paper and recycled paper

Roll paper:

Width	216 mm (8.5 inches)
Thickness	0.07 to 0.09 mm (0.0028 to 0.0035 inches)
Weight	52.3 to 82 g/ m ² (14 to 22 lb)

Printable area:

Single sheets

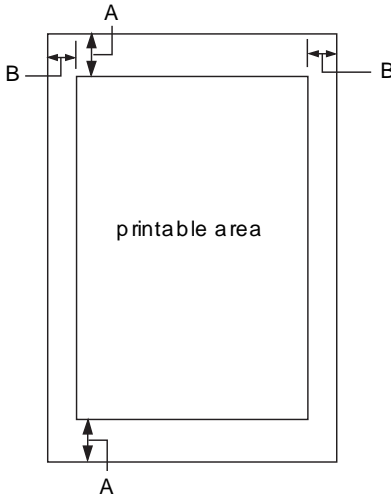

A The minimum top and bottom margins are 0 mm (0 inches).

B The minimum left and right margins are 3.0 mm (0.12 inches). The maximum printable width is 269 mm (10.6 inches).



Continuous paper

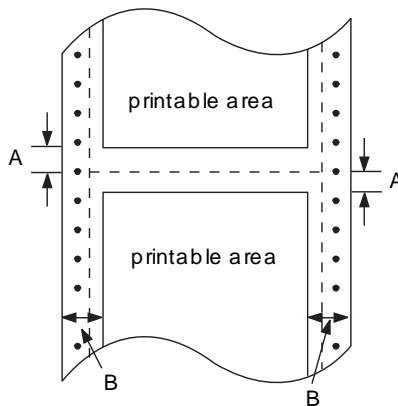

A The minimum top and bottom margins (above and below the perforation) are 4.2 mm (0.17 inches).

B The minimum left and right margins are 13 mm (0.51 inches). The maximum printable width is 269 mm (10.6 inches).

Labels

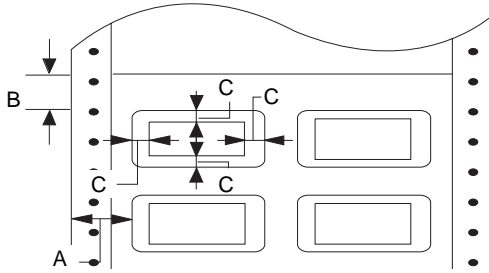

- A 12 mm (0.47 inches) or more
- B 1.2 mm (0.047 inches) or more
- C 3 mm (0.12 inches) or more

Envelopes and postcards

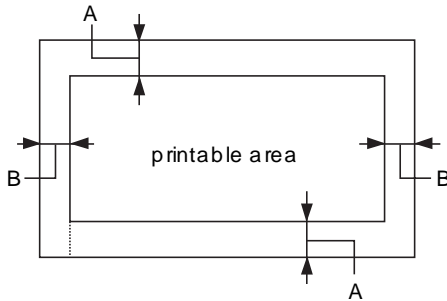

- A The minimum top and bottom margins are 0 mm (0 inches).
- B The minimum left and right margins are 3.0 mm (0.12 inches).

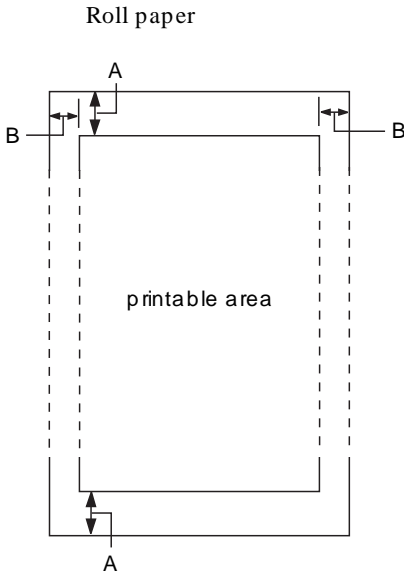

A The minimum top and bottom margins are 0 mm (0 inches).

B The minimum left and right margins are 3.0 mm (0.12 inches).



Mechanical

Paper feed methods:

Friction feed from front
 Built-in push tractor
 Cut-sheet feeder (optional)
 Roll paper holder (optional)

Ribbon:

Black ribbon cartridge (S015016)

Ribbon life

2 million characters (at 10 cpi in letter-quality mode with 48 dots/ character)

Total print amount:

6.5 million lines (except print head)

Print head life:

200 million strokes/ wire

Dimensions and weight
 (with paper guide):

Height: 256 mm (10.1 inches)
 Width: 469 mm (18.5 inches)
 Depth: 429 mm (16.9 inches)
 Weight: Approx. 9.0 kg (19.8 lb)

Electrical

120 V model:

Rated voltage	AC 120 V
Input voltage range	AC 103.5 to 132 V
Rated frequency range	50 to 60 Hz
Input frequency range	49.5 to 60.5 Hz
Rated current	0.7 A (maximum 2.2 A depending on the character type)
Power consumption	Approx. 30 W (ISO/ IEC 10561 Letter pattern)

230 V model:

Rated voltage	AC 220 to 240 V
Input voltage range	AC 198 to 264 V
Rated frequency range	50 to 60 Hz
Input frequency range	49.5 to 60.5 Hz
Rated current	0.4 A (maximum 1.1 A depending on the character type)
Power consumption	Approx. 30 W (ISO/ IEC 10561 Letter pattern)

Environmental

Temperature:	Operation (without condensation): 5° to 35°C (41° to 95°F) 15° to 25°C (59° to 77°F) for multi-part forms, envelopes, postcards, and labels Storage: -30° to 60°C (-22° to 140°F)
Humidity (without condensation):	Operation: 10% to 80% RH 30% to 60% RH (for envelopes and labels) Storage: 0% to 85% RH

Safety approvals

120 V model:

Safety standards	UL1950 with D3 CSA C22.2 No.950 with D3
EMI	FCC part 15 subpart B class B CSA C108.8 class B

230 V model:

Safety standards	EN 60950 (VDE, NEMKO)
EMI	EN 55022 (CISPR pub.22) class B AS/ NZS 3548 class B
Acoustic noise:	Approx. 55 dB (A) (ISO 7779 pattern)

CE marking

230 V model:

Low Voltage Directive 73/ 23/ EEC	EN 60950
EMC Directive 89/ 336/ EEC	EN 55022 Class B
	EN 61000-3-2
	EN 61000-3-3
	EN 50082-1
	IEC 801-2
	IEC 801-3
	IEC 801-4



Parallel Interface Specifications

The printer comes with a bidirectional, 8-bit, parallel interface and an optional interface slot.

Forward channel

Transmission mode:	8-bit parallel, IEEE-1284 compatibility mode
Adaptable connector:	57-30360 (Amphenol) or equivalent
Synchronization:	<u>STROBE</u> pulse
Handshaking:	<u>BUSY</u> and <u>ACKNLG</u> signals
Signal level:	TTL compatible (IEEE-1284 level 1 device)

Reverse channel

Transmission mode:	IEEE-1284 Nibble Mode
Adaptable connector:	57-30360 (Amphenol) or equivalent
Synchronization:	Refer to the IEEE-1284 specification
Handshaking:	Refer to the IEEE-1284 specification
Signal level:	IEEE-1284 Level 1 device
Data transmission timing:	Refer to the IEEE-1284 specification
Extensibility request:	The printer responds to the extensibility request in the affirmative when the request is 00H or 04H, which means:
00H:	Request nibble mode of reverse channel transfer
04H:	Request device ID in nibble mode of reverse channel transfer

Optional Cut-Sheet Feeder Specifications

The specifications below apply to both the high-capacity cut-sheet feeder (C80678*, bin 1) and the second-bin cut-sheet feeder (C80679*, bin 2).

Note:

You can load the same types of single sheets, multi-part forms, envelopes, and postcards in the high-capacity cut-sheet feeder as you load in the printer's paper guide. You can load only single-sheet paper in the second-bin cut-sheet feeder. For paper specifications, see page A-4.

Capacity of bin 1:

Single sheets	
A3 size paper	Up to 110 sheets of 82 g/m ² (22 lb) paper Up to 135 sheets of 64 g/m ² (17 lb) paper
Other paper	Up to 150 sheets of 82 g/m ² (22 lb) paper Up to 185 sheets of 64 g/m ² (17 lb) paper
Single-sheet multi-part forms	Up to 40 sheets of 47 g/m ² (12.5 lb) paper
Envelopes	Up to 25 plain or bond envelopes Up to 30 airmail envelopes
Postcards	Up to 50 plain paper cards

Note:

The total thickness of the paper stack can be up to 15 mm (0.59 inches).

If the weight of your paper differs from the values above, the total thickness of the paper stack should be less than 15 mm (0.59 inches).

Capacity of bin 2:

Single sheets	Up to 50 sheets of 82 g/m ² (22 lb) paper Up to 60 sheets of 64 g/m ² (17 lb) paper
---------------	--------------------------------------------------------------------------------------------------------------

Note:

The total thickness of the paper stack can be up to 5 mm (0.20 inches).



Environmental:

Temperature	Operation: 5° to 35°C (41° to 95°F) Storage: -30° to 60°C (-22° to 140°F)
Humidity (without condensation)	Operation: 10% to 80% RH Storage: 0% to 85% RH

Dimensions and weight (including the printer):

With only bin 1 installed	Height: 446 mm (17.6 inches) Width: 469 mm (18.5 inches) Depth: 660 mm (26.0 inches) Weight: 11.0 kg (24.3 lb)
With bin 1 and bin 2 installed	Height: 446 mm (17.6 inches) Width: 469 mm (18.5 inches) Depth: 733 mm (28.9 inches) Weight: 11.8 kg (26.0 lb)

Appendix B

Command Lists and Character Tables

EPSON ESC/ P 2 Control Codes	B-2
Barcode command	B-3
IBM 2390 Plus Emulation Control Codes	B-6
Character Tables in EPSON ESC/ P 2 Mode	B-7



EPSON ESC/P 2 Control Codes

Selecting EPSON ESC/ P 2 printer in your software allows you to use the most advanced font and graphics handling available. See the *ESC/P Reference Manual* for details.

General operation:

ESC @, ESC U, ESC EM

Paper feeding:

FF, LF, ESC 0, ESC 2, ESC 3, ESC +, CR

Page format:

ESC (C, ESC C, ESC C 0, ESC Q, ESC I, ESC (c, ESC N, ESC O

Print position motion:

ESC \$, ESC ¥, ESC (V, ESC (v, ESC D, HT, ESC B, VT, ESC J

Font selection:

ESC k, ESC x, ESC X, ESC P, ESC M, ESC g, ESC p, ESC 4, ESC 5, ESC E, ESC F, ESC !

Font enhancement:

ESC W, DC 4, SO, DC2, SI, ESC w, ESC G, ESC H, ESC T, ESC S, ESC -, ESC (-, ESC q

Spacing:

ESC Space, ESC c, ESC (U

Character handling:

ESC t, ESC (t, ESC R, ESC %, ESC &, ESC :, ESC 6, ESC 7, ESC (^

Bit image:

ESC *

Graphics:

ESC (G, ESC .

Bar code:

ESC (B

Barcode command

Your printer has powerful barcode printing capabilities and includes the following resident barcode fonts: EAN-13, EAN-8, Interleaved 2 of 5, UPC-A, UPC-E, Code 39, Code 128, and POSTNET. See the barcode commands below:

ESC (B Select Barcode Printing

Format:

ASCII code:	ESC	(B	m	n
Decimal:	27	40	66	m	n
Hexadecimal:	1B	28	42	m	n

Function:

ESC (B n1 n2 k m s v1 v2 c data

$n = (n1 + (256 \times n2))$

k: Select barcode

k = 0: EAN - 13, 1: EAN - 8, 2: Interleaved 2 of 5, 3: UPC - A,
4: UPC - E, 5: Code 39, 6: Code 128, 7: POSTNET

m: Module width (180 dpi)

m = 2: 2 dots, 3: 3 dots, 4: 4 dots, 5: 5 dots

s: Space adjustment value

$-3 \leq s \leq 3$ (1/ 360-inch units)

v1, v2: Bar length

$v1 + v2 \times 256$ (1/ 180-inch units)

- The v1 and v2 values are ignored when POSTNET is selected.
- The long bar length of POSTNET is always 0.125 inches; the short bar length is always 0.050 inches.

B

c: Control flag

Bit 0 = Check digit

0: The printer does not add a check digit.

1: The printer adds a check digit.

Bit 1 = Human readable character (HRC)

0: The printer adds the HRC.

1: The printer does not add the HRC.

Bit 2 = Position of flag character (for EAN-13 and UPC-A only)

0: Center

1: Under

Bits 3–7 = Not used

Barcode data

Barcode data corresponds to the barcode symbology. The data number of each barcode type is constant. The barcode is printed only if the following valid characters are set.

Barcode type	Number of valid characters 1 (HEX)	Number of valid characters 2 (HEX)
EAN-13	0D	0C
EAN-8	8	7
Interleaved 2 of 5	2 to FF	2 to FF
UPC-A	0C	0B
UPC-E	0C or 8	0B or 7
Code 39	1 to FF	1 to FF
Code 128	2 to FF	2 to FF
POSTNET	6 or 0A or 0C	5 or 9 or 0B

Number of valid characters 1: Control flag c b0=0

Number of valid characters 2: Control flag c b0=1

The valid data of each barcode type is described below. If invalid data is included in the barcode data string, the barcode is not printed.

Barcode type	Barcode data
EAN-13	0-9 (Hex 30-39)
EAN-8	0-9 (Hex 30-39)
UPC-A	0-9 (Hex 30-39)
UPC-E	0-9 (Hex 30-39)
Interleaved 2 of 5	0-9 (Hex 30-39)
POSTNET	0-9 (Hex 30-39)
Code 39	0-9 (Hex 30-39), (Hex 41-5A), (Hex 20, 24, 25, 2B, 2D, 2E, 2F)
Code 128	Set A, Set B, Set C

The following conditions are required for barcode printing:

- Barcode printing is always performed unidirectionally. However, when it is mixed with raster bit image data, neither barcode nor raster bit image data is printed.
- A barcode is not printed when part of the barcode extends beyond the right margin.
- When barcode data and text data are mixed in a data sequence, barcode and text are printed in the same place.
- The start and stop (*) characters of Code 39 are added to human readable characters.
- The initial data of Code 128 (Set A, B, or C) is identified as the first data of Code 128, and must be hexadecimal (41, 42, and 43, respectively).
- When Code 128 Set C and Interleaved 2 of 5 are selected, barcode data requires an even number data string. However, if an odd number string is sent, a 0 is automatically added, making it an even number data string.
- The barcode print start position (except for POSTNET) is always 40/ 360 inch above the baseline.

IBM 2390 Plus Emulation Control Codes

This printer emulates the IBM Proprinter with the following commands.
For detailed information, see the IBM 2390 Plus reference manual.

General operation:

NUL, DC3, ESC j, BEL, CAN, DC1, ESC Q, ESC [K, ESC U, ESC [F

Paper feeding:

FF, LF, ESC 5, ESC A, ESC A (AGM*), ESC 0, ESC 1, ESC 2, ESC 3,
ESC 3 (AGM*), CR, ESC]

Page format:

ESC C, ESC C0, ESC X, ESC N, ESC O, ESC 4

Print position motion:

ESC d, ESC R, ESC D, HT, ESC B, VT, ESC J, ESC J (AGM*)

Font selection:

DC2, ESC P, ESC :, ESC E, ESC F, ESC I, ESC [d, ESC [I

Font enhancement:

DC4, SO, ESC SO, ESC W, ESC [@, SI, ESC SI, ESC G, ESC H, ESC T,
ESC S, ESC -, ESC _, ESC [-

Spacing:

BS, SP, ESC [¥

Character handling:

ESC 6, ESC 7, ESC [T, ESC ^, ESC ¥

Bit image:

ESC K, ESC L, ESC Y, ESC Z, ESC [g, ESC * (AGM*)

Barcode:

ESC [f, ESC [p

* Alternate Graphics Mode

Character Tables in EPSON ESC/P 2 Mode

When the printer is in EPSON ESC/P 2 mode, the character tables below can be selected using software commands.

All character tables except the italic table are the same as the PC437 table for hex codes 00 through 7F, so only the PC437 and italic tables are shown completely. The rest of the character tables show only the characters for hex codes 80 through FF.

The tables with an asterisk (*) after the table name are available only in certain areas.

PC437 (USA)

B

PC850 (Multilingual)

PC860 (Portuguese)

PC863 (Canadian-French)

PC865 (Norwegian)

PC861 (Icelandic)

BRASCII (Brazilian Portuguese)

Abicomp (Brazilian Portuguese) ISO Latin 1

B

Roman 8

PC437 Greek (Greek)*

PC869 (Greek)*

*ISO 8859-7 (Latin/Greek)**

*PC853 (Turkish)**

*PC857 (Turkish)**

*ISO Latin 1T(Turkish)**

B

PC855 (Cyrillic)*

PC866 (Russian)*

PC852 (East Europe)*

MAZOWIA (Poland)*

*Code MJK (CSFR)**

*Bulgaria (Bulgaria)**

*PC864 (Arabic)**

*Estonia (Estonia)**

B

PC774 (LST1283:1993)*

ISO 8859-2*

PC866 LAT. (Latvian)*

Italic

No character is
available for hex
code 15 in the italic
character table.

Characters available with the ESC (^ command

To print the characters in the tables below, use the ESC (^ command. The characters in the right table are available with PC864 (Arabic) only.

International character sets

You can select one of the following international character sets by sending the ESC R command. For example, when you select “Italic France,” the characters in the “France” row in the table below are used in the italic character table.

The following eight international character sets can be selected with the default-setting mode or with the ESC R command.

B

The following seven additional sets can be selected only with the ESC R command.

Appendix C

Contacting Customer Support

For United States Users	C-2
Electronic support services	C-3
For United Kingdom and the Republic of Ireland Users	C-4
Enquiry Desk	C-4
Customer Support	C-4
Faxon EPSON	C-5
EPtec - Bulletin Board Service for latest drivers and utilities	C-5
World Wide Web	C-5
For Australian Users	C-6
EPSON FAXBACK	C-6
EPSON Bulletin Board System	C-6
Internet URL http:// www.epson.com.au	C-6
Your dealer	C-6
EPSON Helpdesk	C-7
For Singapore Users	C-7
For Hong Kong Users	C-8
Internet home page	C-8
Electronic bulletin board system	C-8
Technical Support Hotline	C-8
For Philippines Users	C-9



If your printer is not operating properly and you cannot solve the problem using the troubleshooting information in this guide, contact customer support services for assistance.

We will be able to help you much more quickly if you give us the following information:

Serial number of your printer:

(The serial number label is on the back of the printer.)

Printer model:

Brand and model of your computer:

Printer software version:

(Click the About button in your printer driver.)

Windows version (for example, 95 or 3.1) you are using:

Software application(s) you normally use with your printer and their version number(s):

For United States Users

If you purchased your printer in the United States or Canada, EPSON provides customer support and service through a network of authorized EPSON Customer Care Centers. Dial (800) 922-8911 for the nearest location or the following services:

- Fax-on-Demand access to EPSON's technical information library
- Literature on current and new products
- The location of your nearest Authorized EPSON Reseller or Customer Care Center
- Technical information on installation, configuration, and operation of EPSON products
- Customer relations.

For answers to commonly asked questions about EPSON products 24 hours a day, 7 days a week, call EPSON Sound Advice at (800) 442-2110.

You can purchase manuals, accessories, or parts from EPSON Accessories at (800) 873-7766 (U.S. sales only). In Canada, please call (800) 873-7766 for dealer referral.

If you need help using software with an EPSON product, see the documentation for that program for technical support information.

Electronic support services

You can access helpful tips, specifications, DIP switch or jumper settings, drivers, FAQs, sample files, application notes, and EPSON product bulletins 24 hours a day, 7 days a week, using a modem and one of the online services below.

World Wide Web

From the Internet, you can reach EPSON's home page at
<http://www.epson.com>

EPSON Internet FTP site

If you have Internet FTP capability, use your Web browser (or other software for FTP downloading) to log onto <ftp.epson.com> with the user name anonymous and your e-mail address as the password.

EPSON Download Service

You can call the EPSON Download Service BBS at (800) 442-2007. Set your communications software to 8 data bits, 1 stop bit, no parity. Modem speed can be up to 28.8 Kbps.

EPSON Fax-on-Demand Service

You can access EPSON's technical information library by calling (800) 442-2110 or (800) 922-8911 and selecting the appropriate phone option. You must provide a return fax number to use Fax-on-Demand.

EPSON Forum on CompuServe®

Members of CompuServe can type GO EPSON at the menu prompt to reach CompuServe's Epson America Forum. As an owner of an EPSON product, you are eligible for a free introductory CompuServe membership, which entitles you to an introductory credit and your own user ID and password. To take advantage of this offer in the U.S. or Canada, call (800) 848-8199 and ask for representative #529.



For United Kingdom and the Republic of Ireland Users

If you purchased your printer in the UK or the Republic of Ireland, Epson (UK) Limited provides a range of customer services and technical support.

Note:

For customers in the Republic of Ireland, please use the correct dialing codes when dialing the UK telephone numbers listed in the following sections. For example the Enquiry Desk fax number, 01442 227271, should be dialed as 0044 1442 227271 from the Republic of Ireland.

Enquiry Desk

The Enquiry Desk team can be contacted by calling 0800 220546 in the UK or 1 800 409132 from the Republic of Ireland, by faxing 01442 227271, or via the Internet at info@epson.co.uk. They can provide the following information:

- Information and literature on new EPSON products (also available from Faxon EPSON)
- Where to purchase genuine EPSON consumables, accessories and options

Customer Support

Our Customer Support team can provide the following services:

- Technical information on installing, configuring, and operating your EPSON products
- Arranging for faulty EPSON products to be repaired within the warranty period

For information on contacting our Customer Support team, please see the Service and Support Information booklet that came with your EPSON product.

If this booklet is not available, details can be found on Faxon EPSON faxback service, EPtec Bulletin Board Service or on EPSON's World Wide Web site. See below for details.

Faxon EPSON

Contact Faxon EPSON Faxback Service for:

- Literature and specifications on the latest EPSON products
- Support information including troubleshooting tips, switch settings and driver information

To use Faxon EPSON, call 01442 227332 using a touch-tone phone. You will be asked to follow a simple routine to register your document request and once you have entered your telephone and fax numbers, Faxon EPSON will fax a copy of the document catalogue to your fax machine.

When you have found the documents that you need in the catalogue, call Faxon EPSON again and enter the document ID numbers. The documents will be faxed to you automatically.

EPtec - Bulletin Board Service for latest drivers and utilities

You can call the EPSON Bulletin Board Service on 01442 227479. No membership is required. Make sure that your communications software is set to 8 data bits, 1 stop bit, no parity bit, ANSI terminal mode emulation and a modem speed of up to 28.8 Kbps. Downloading protocols supported include Xmodem, Ymodem and Zmodem. See the documentation that came with your communications software and modem for more information.

When you first connect to the Bulletin Board Service, you will be asked for your name, company name, phone number and a password (which you can invent yourself).

World Wide Web

If you can connect to the Internet and have a Web browser, you can access EPSON's World Wide Web site at <http://www.epson.com>. Here you will find information on the latest EPSON products, software drivers, and answers to frequently asked questions.



For Australian Users

EPSON Australia wishes to provide you with a high level of Customer Service. As well as this *User's Guide*, we provide the following sources for obtaining information:

EPSON FAXBACK

EPSON FAXBACK will fax you the latest specifications and pricing for most EPSON products offered in Australia. There is also technical information including details of the latest software and drivers available. Phone (02) 9903 9075 and the system will guide you through a number of choices before faxing the information to your fax machine.

EPSON Bulletin Board System

This is where you can download the latest software and drivers. Visit the BBS to check out the latest versions. If you have a modem, phone (02) 9417 5090.

Internet URL <http://www.epson.com.au>

Access the Epson Australia World Wide Web pages. Worth taking your modem here for the occasional surf! You can get the same information as offered on the EPSON FAXBACK and the EPSON Bulletin Board plus more.

Your dealer

Don't forget that your dealer can often help identify and resolve problems. The dealer should always be the first call for advice on problems. They can often solve problems quickly and easily as well as give you advice on the next step to take.

EPSON Helpdesk

EPSON Helpdesk is provided as a final backup to make sure our clients have access to advice. Operators on the Helpdesk can aid you in diagnosing hardware and software problems. They can also advise you on the latest EPSON products and where the nearest dealer or service agent is located. Many types of queries are answered here.

Access to the Helpdesk is at no charge to purchasers of new products for the first 12 months of that product's life. After that period, a different phone number is used and charges are debited to your telephone account. The current charge rates are specified when you ring the chargeable support number. You are asked to signify your acceptance before any charges are incurred.

The Helpdesk numbers are:

first 12 months	(02) 9903 9040
after 12 months	1 902 263 192
fax number	(02) 9903 9189

We encourage you to have all the relevant information on hand when you ring. The more information you prepare, the faster we can help solve the problem. This information includes the *User's Guide* for your EPSON product, type of computer, operating system, application programs, and any other information you feel is required.

For Singapore Users

Contact the telephone and fax numbers below:

Phone:	(065) 337-7911
Fax:	(065) 334-1185



For Hong Kong Users

To obtain technical support as well as other after-sales services, users are welcome to contact EPSON Hong Kong Limited.

Internet home page

EPSON Hong Kong has established a local home page in both Chinese and English on the Internet to provide users with the following information:

- Product information
- Answers to Frequently Asked Questions (FAQs)
- Latest versions of EPSON printer drivers

Users can access our World Wide Web home page at:
[http:// www.epson.com.hk](http://www.epson.com.hk).

Electronic bulletin board system

An electronic bulletin board system (BBS) is also available to obtain printer information and the latest versions of printer drivers. You can log on to the following number for the BBS service:

BBS: (852) 2827-4244

Technical Support Hotline

You can also contact our technical staff at the following telephone and fax numbers:

Phone: (852) 2585-4399
Fax: (852) 2827-4383

For Philippine Users

To obtain technical support as well as other after sales services, users are welcome to contact the EPSON Philippines Representative Office at the telephone and fax numbers below:

Phone:	(632) 813-6552
Fax:	(632) 813-6545
BBS:	(632) 814-0595

A black square containing a white capital letter 'C'.

Glossary

ASCII

American Standard Code for Information Interchange. A standardized coding system for assigning numerical codes to letters and symbols.

auto line feed

When this feature is selected in the default-setting mode or the EPSON Remote! utility, each carriage-return (CR) code is automatically followed by a line-feed (LF) code.

bidirectional printing

Printing in which the print head prints in both directions (bidirectionally). This increases the print speed but may reduce precise vertical alignment. Bidirectional printing is this printer's standard printing mode. See also *unidirectional printing*.

buffer

The portion of the printer's memory used to store data before it is printed.

character table

A collection of letters, numbers, and symbols that constitute the set of characters used in a particular language.

characters per inch (cpi)

A measurement of the size of text characters.

condensed printing

Printing in which the width of each character is approximately 60% of the width of standard characters. Useful for fitting wide tables or spreadsheets onto the paper.

continuous paper

Paper that has sprocket-feed holes on both sides, is perforated between pages, and is supplied in a folded stack. Also called fanfold paper.

control code

A special code used to control a printer function such as performing a carriage return or line feed.

cpi

See *characters per inch*.

cut-sheet feeder

An optional, detachable device that automatically feeds single sheets of paper into the printer.

data dump

See *hex dump*.

default

A value or setting that takes effect when the equipment is turned on, reset, or initialized.

dithering

A way of arranging dots on a page to simulate a shade or tone.

dot matrix

A method of printing in which each letter or symbol is formed by a pattern (matrix) of individual dots.

draft

The print mode used by your printer when you select Draft as the font. The Draft font uses less dots per character for faster printing. See also *high-speed draft* and *letter quality*.

driver

See *printer driver*.

ESC/P

Abbreviation for EPSON Standard Code for Printers. This is the system of commands your computer uses to control your printer. It is standard for all EPSON printers and supported by most application software for personal computers.

ESC/P 2

The enhanced version of the ESC/ P printer command language. Commands in this language produce laser-like results, such as scalable fonts and enhanced graphics.

fanfold paper

See *continuous paper*.

font

A style of type designated by a name such as Roman or Sans Serif.

form feed (FF)

A control code and control panel button that advances the paper to the next top-of-form position.

hex dump

A troubleshooting feature that helps identify the cause of communication problems between the printer and the computer. When the printer is in hex dump mode, it prints each code that it receives is printed in hexadecimal notation and ASCII characters. Also called data dump.

high-speed draft

A mode of draft printing you can select using the default-settings mode or the EPSON Remote! utility. High-speed draft uses a minimum number of dots per character to produce extremely high-speed printing. See also *draft* and *letter quality*.

interface

The connection (via a cable) between the computer and the printer over which print data is transmitted to the printer.

letter quality (LQ)

The print mode used by your printer when a font other than Draft is selected. Printing with letter-quality fonts provide better readability and appearance at a reduced print speed. See also *draft* and *high-speed draft*.

line feed (LF)

A control code and control panel button that advances the paper one line space.

loading position

The position to which the paper is automatically loaded. It can be adjusted with the micro adjust feature.

platen

The black roller that provides a backing for the paper during printing.

printable area

The area of a page on which the printer can print. It is smaller than the physical size of the page due to margins.

printer driver

A software program that sends commands from the computer for using the functions of a particular printer.

reset

To return a printer to its defaults settings.

resolution

A measure of the amount of detail that can be represented. Resolution of printed images is measured in number of dots per inch (dpi).

self test

A method for checking the operation of the printer. When you run the self test, the printer prints the characters stored in its ROM (Read Only Memory).

tear off

A control panel button that feeds the perforation of continuous paper to the tear-off position and then feeds the paper back to the top-of-form position.

tear-off position

The position the printer feeds the paper to when you press the **Tear Off/Bin** button or when auto tear-off mode is on. Using the micro adjust feature, you can adjust the position so that the paper's perforation meets the printer's tear-off edge.

top-of-form position

The position on the paper that the printer recognizes as the first printable line. This is the default top-margin position.

unidirectional printing

Printing in which the print head prints in one direction only.

Unidirectional printing is useful for printing graphics because it allows precise vertical alignment. You can select unidirectional printing in the printer's default-setting mode or the EPSON Remote! utility. See also *bidirectional printing*.

Index

A

- Adjusting
 - loading position, 3-27–29
 - printing position, 3-29–30
 - tear-off position, 3-31–32
- AGM (Alternate Graphics Mode) setting, 4-14
- Assembling the printer, 1-5–9
- Auto CR (carriage return) setting, 4-13
- Auto I/ F wait time setting, 4-12
- Auto line feed setting, 4-11
- Auto tear-off, 3-18–19
- Auto tear-off setting, 4-11

B

- Barcode commands, B-3–5
- Baud rate, 5-21
- Bidirectional adjustment mode, 7-24–25
- Bidirectional (Bi-d) printing, print direction setting, 4-11
- Bin 1 (cut-sheet feeder), 4-4, 4-6–7, 5-2, 5-7–10
- Bin 2 (cut-sheet feeder), 4-4, 4-6–7, 5-2, 5-11–12
- Buttons, 4-4–7
- Buzzer (beep) setting, 4-13

C

- Cables. *See* Interface cable
- Card mode, 3-24, 4-4, 4-6–7
- Cards. *See* Interface cards *or* Postcards

- Character table setting, 4-12
- Character tables, B-7–16
- Choosing a place for the printer, 1-3–4
- Cleaning the printer, 6-5–6
- Clearing a paper jam, 7-24
- Command lists, B-2–6
- Condensed
 - button, 4-6, 4-8
 - light, 4-3
- Connecting the printer to your computer, 1-10–11
- Continuous paper, 3-9–20
 - loading, 3-11–16
 - problems, 7-10–13
 - removing, 3-20
 - switching to and from, 3-25–27, 5-13
 - using the tear-off function with, 3-16–19
- Control codes
 - ESC/ P 2, B-2–5
 - IBM 2390 Plus emulation, B-6
- Control panel functions, 4-2–8
 - buttons, 4-4–7
 - lights, 4-3–4
- Customer support, Appendix C
- Cut-sheet feeders, 5-2–14
 - double bin, 5-2, 5-3, 5-11–12
 - high capacity, 5-2, 5-7–10
 - installing, 5-3–6
 - loading paper, 5-6–12
 - problems, 7-14–16
 - second bin, 5-2, 5-11–12
 - specifications, A-13–14

D

Default-setting mode, 4-9–15
 option descriptions, 4-10–14
 options table, 4-9–10
 changing, 4-14–15
Dithering setting, 2-8, 2-12
DOS, 2-12–14
Double-bin cut-sheet feeder, 5-2, 5-3,
 5-11–12
Draft font, 4-5
Driver. *See* Printer driver

E

Edge guides, 3-8
Eject. *See* Load/ Eject button
Emulation, IBM, 1, 4-12, B-6
Envelopes, 3-23
EPSON Remote! utility, 2-14
ESC/ P 2, 1, 4-12, B-2–5
Error indicators, 7-3

F

Feeders. *See* Cut-sheet feeders
Feeding methods, 3-2–3
FF button. *See* LF/ FF button
Font
 button, 4-5–6, 4-8
 lights, 4-3
 setting, 4-14

H

Handshake timing, 5-21
High-capacity cut-sheet feeder, 5-2,
 5-7–10
High-speed draft setting, 4-13
Hex dump mode, 7-5–6

I

IBM 2390 Plus emulation, 1, 4-12, B-6
I/ F mode setting, 4-12
Input buffer setting, 4-13
Intensity setting, 2-8
Intensity Control setting, 2-12
Interface cable, connecting, 1-10
Interface cards, 5-19–21
International character set for Italic
 table setting, 4-12
International character sets, B-15–16
Italic character table, 4-12, B-14

K

Knob, 1-5

L

Labels, 3-21–22
Letter-quality printing, 4-5
LF/ FF button, 4-5, 4-7, 4-8
Lights, 4-3–4
Load/ Eject button, 4-4, 4-7, 4-8
Loading paper
 continuous paper, 3-11–16
 envelopes, 3-23
 from the cut-sheet feeder, 5-7–14
 labels, 3-21–22
 manually from the sheet guide,
 5-14
 multi-part forms, 3-20–21
 postcards, 3-24
 roll paper, 5-17–18
 single sheets, 3-6–9

M

- Microsoft Windows. *See* Windows
- Micro Adjust, 3-27–32
 - loading position, 3-27–29
 - printing position, 3-29–30
 - tear-off position, 3-31–32
- Multi-part forms, 3-20–21

O

- Operate button, 1-9, 4-4
- Operation, problems, 7-16–18
- Options, 2
 - cut-sheet feeders, 5-2–14
 - roll-paper holder, 5-15–17
 - interface cards, 5-19–21
- Orientation setting, 2-8, 2-12

P

- Page length for tractor setting, 4-10
- Paper
 - continuous. *See* Continuous paper envelopes, 3-23
 - feeding methods, 3-2–3
 - handling problems, 7-8
 - jams, 7-24
 - labels, 3-21–22
 - multipart forms, 3-20–21
 - postcards, 3-24
 - removing continuous paper, 3-20
 - single sheet. *See* single-sheet paper
 - specifications, A-4–8
 - switching between continuous paper and single sheets, 3-25–27, 5-13

- Paper guide, 1-9
- Paper Out light, 4-3
- Paper release lever, 3-4
- Paper size setting, 2-8, 2-11
- Paper source setting, 2-8, 2-12
- Paper thickness lever, 3-5–6
- Pause
 - button, 4-4, 4-8
 - light, 4-3
- Plug-and-play, 2-2
- Plugging in the printer, 1-9
- Postcards, 3-24
- Power cord, 1-2, 1-9
- Power supply, problems, 7-7
- Print direction setting, 4-11
- Print head
 - damaged, 7-19
 - overheated, 7-18
 - warning, 1-6
- Printer driver
 - accessing,
 - Windows 3.1, 2-10–11
 - Windows 95, 2-7
 - checking and changing,
 - Windows 3.1, 2-11–12
 - Windows 95, 2-8
 - installing,
 - for DOS, 2-12
 - for Windows 3.1, 2-9
 - for Windows 95, 2-2–6
- Printer utility, 2-14
- Printout, problems, 7-18–23
- Problems and solutions, 7-6–23
- Protective materials, saving, 1-2–3

Q

- Quiet mode, 4-16

R

Release lever. *See* Paper release lever
Remote!. *See* EPSON Remote!
Resolution setting, 2-8, 2-11
Ribbon cartridge
 installing, 1-6-8
 replacing, 6-2-5
Roll paper holder, 5-15-18

S

Safety instructions, iv-v
Second-bin cut-sheet feeder, 5-2
 5-11-12
Self test, 7-4-5
Sheet guide, 5-3
Single-sheet
 feeding position, 3-4
 paper, 3-6-9
Skip-over-perforation setting, 4-11
Software setting, 4-12
Specifications, A-2-14
Sprocket
 cover, 3-7, 3-14
 lock lever, 3-7, 3-12
 unit, 3-7, 3-12

T

Tear Off/ Bin
 button, 4-6-7
 light, 4-4
Tear-off function, 3-16-19
Tractor, 3-3
Tractor feeding position, 3-4
Transporting the printer, 6-6
Troubleshooting, Chapter 7
 operation, 7-16-18
 paper handling, 7-8-16
 power supply, 7-7
 printout, 7-18-23

U

Unidirectional (Uni-d) printing,
 print direction setting, 4-11
Unpacking the printer, 1-2-3
Utility, EPSON Remote!, 2-14

V

Voltage
 caution, 1-3, 1-9
 mismatched, 7-7

W

Windows printer driver
 Windows 3.1, 2-9-12
 Windows 95, 2-2-8